

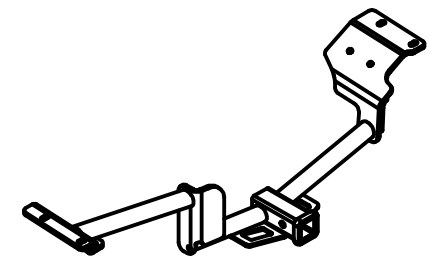

Class III Receiver Hitch

Part No. 69552C



Fits: FORD FLEX, FLEX ECOBOOST, LINCOLN MKT



GROSS LOAD CAPACITY WHEN USED AS A WEIGHT CARRYING HITCH: 4,000 LBS. TRAILER WEIGHT & 400 LBS. TONGUE WEIGHT.
GROSS LOAD CAPACITY WHEN USED AS A WEIGHT DISTRIBUTION HITCH: 4,000 LBS. TRAILER WEIGHT & 400 LBS. TONGUE WEIGHT
WARNING: * DO NOT EXCEED VEHICLE MANUFACTURER'S RECOMMENDED TOWING CAPACITY. *****



Parts List			
ITEM	QTY	PART NUMBER	DESCRIPTION
1	4	M12-1.75 x 40mm	HEX BOLT
2	4	1/2"	CONICAL TOOTHED WASHER

RUBBER ISOLATOR REMOVAL DIAGRAM

This technique can be used if an Exhaust Hanger Removal Pliers is not available.

Using a 5/8" open end wrench, slide the wrench up to the rubber isolator, cradling the hanger rod as shown. Next place the flat edge of a pry bar between the wrench and the hanger stop or hanger rod. Then simply rotate the pry bar toward the wrench to remove the rubber isolator.

Note: Using a spray lubricant or soapy water on the hanger rod and the rubber isolator helps removal.

WELDNUT CLEANING

To remove debris from weldnuts in frame, spray lubricant or compressed air into hole. For heavy debris, use a small wire brush. (Be careful not to damage threads).

TOOLS REQUIRED
RATCHET
10" EXTENSION
18mm & 19mm SOCKETS
TORQUE WRENCH

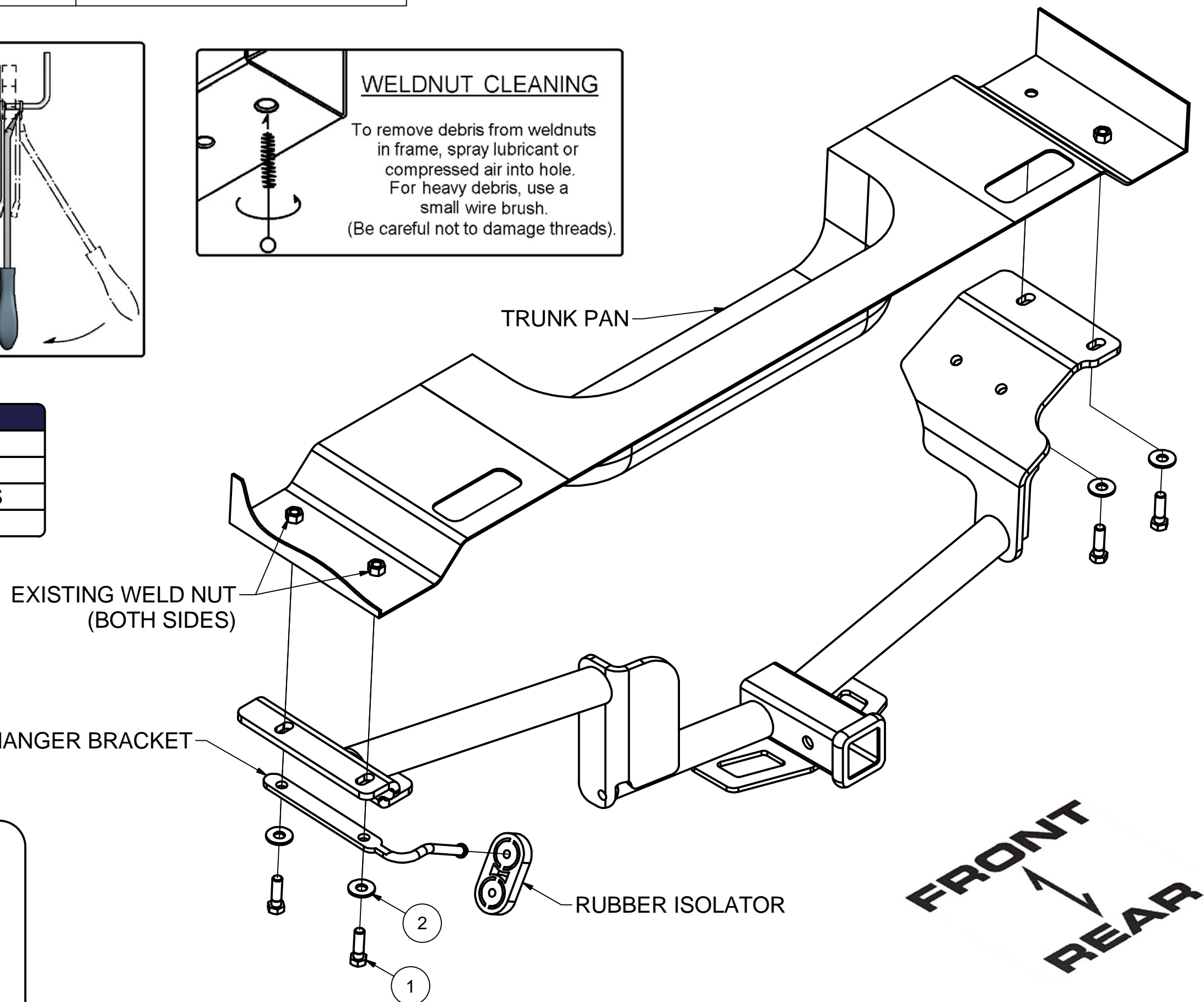

HITCH WEIGHT: 39 LBS.

INSTALL TIME

PROFESSIONAL: 40 MINUTES

NOVICE (DIY): 85 MINUTES

INSTALL NOTES:

- LOWER EXHAUST
- NO DRILLING

INSTALLATION STEPS

NOTE: The Ford Flex Ecoboost and the Lincoln MKT models have dual exhaust. Repeat instruction for passenger side.

- 1) Lower the exhaust by removing (3) rubber isolators. (See Rubber Isolator Removal Diagram above.)
- 2) remove muffler hanger bracket by removing bolts (2). Return bolts to vehicle owner.
- 3) Rotate the hitch into position above the exhaust and align slots with existing weld nuts.
- 4) Secure the passenger side using the existing weld nuts, the M12 hex head bolts and the 1/2" conical toothed washers provided.
- 5) Sandwich the driver side with the muffler hanger bracket and secure using the M12 hex head bolts and the 1/2" conical toothed washers provided.
- 5) Torque all M12 fasteners to 86 ft. lbs.
- 6) Raise exhaust back into position.

PERIODICALLY CHECK THIS RECEIVER HITCH TO ENSURE THAT ALL FASTENERS ARE TIGHT AND THAT ALL STRUCTURAL COMPONENTS ARE SOUND.

Keystone Automotive Operations Inc., warrants this product to be free of defects in material and/or workmanship at the time of retail purchase by the original purchaser. If the product is found to be defective, Keystone Automotive Operations Inc., may repair or replace the product, at their option, when the product is returned, prepaid, with proof of purchase. Alteration to, misuse of, or improper installation of this product voids the warranty. Keystone Automotive Operations Inc.'s liability is limited to repair or replacement of products found to be defective, and specifically excludes liability for incidental or consequential loss or damage. This product complies with safety specifications and requirements for connecting devices and towing systems of the state of New York, V.E.S.C.

11202017