

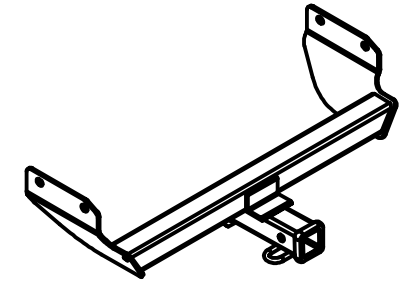

Class III Receiver Hitch

Part No. 69532C



Fits: JEEP GRAND CHEROKEE



GROSS LOAD CAPACITY WHEN USED AS A WEIGHT CARRYING HITCH: 5,000 LBS. TRAILER WEIGHT & 500 LBS. TONGUE WEIGHT.
GROSS LOAD CAPACITY WHEN USED AS A WEIGHT DISTRIBUTION HITCH: 7,500 LBS. TRAILER WEIGHT & 750 LBS. TONGUE WEIGHT

WARNING: *** DO NOT EXCEED VEHICLE MANUFACTURER'S RECOMMENDED TOWING CAPACITY. ***



INSTALLED HITCH POSITION

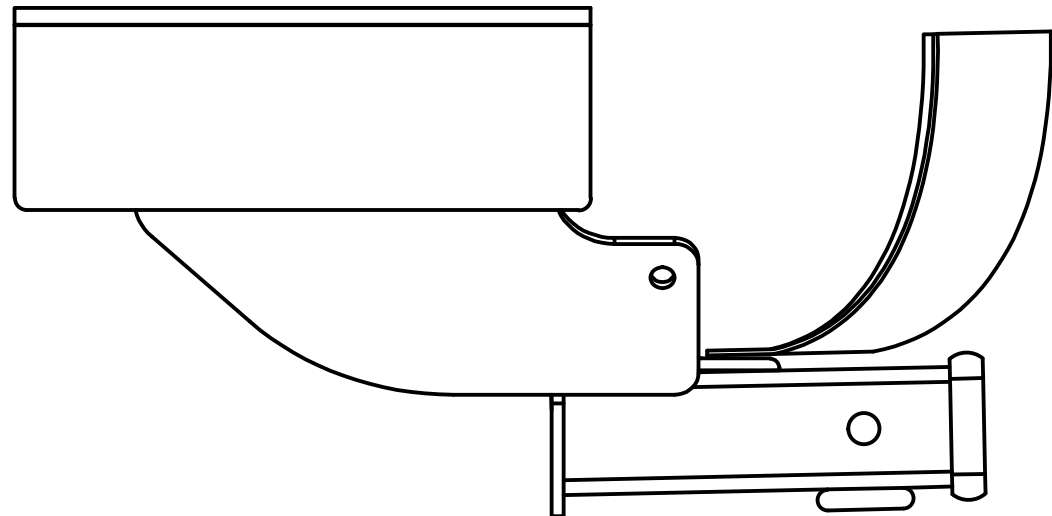

TOOLS REQUIRED
RATCHET
21mm SOCKET
TORQUE WRENCH

PASSENGER SIDE FRAME RAIL

DRIVER SIDE FRAME RAIL

EXISTING WELDNUTS
(BOTH SIDES)

EXISTING HARDWARE
(BOTH SIDES)

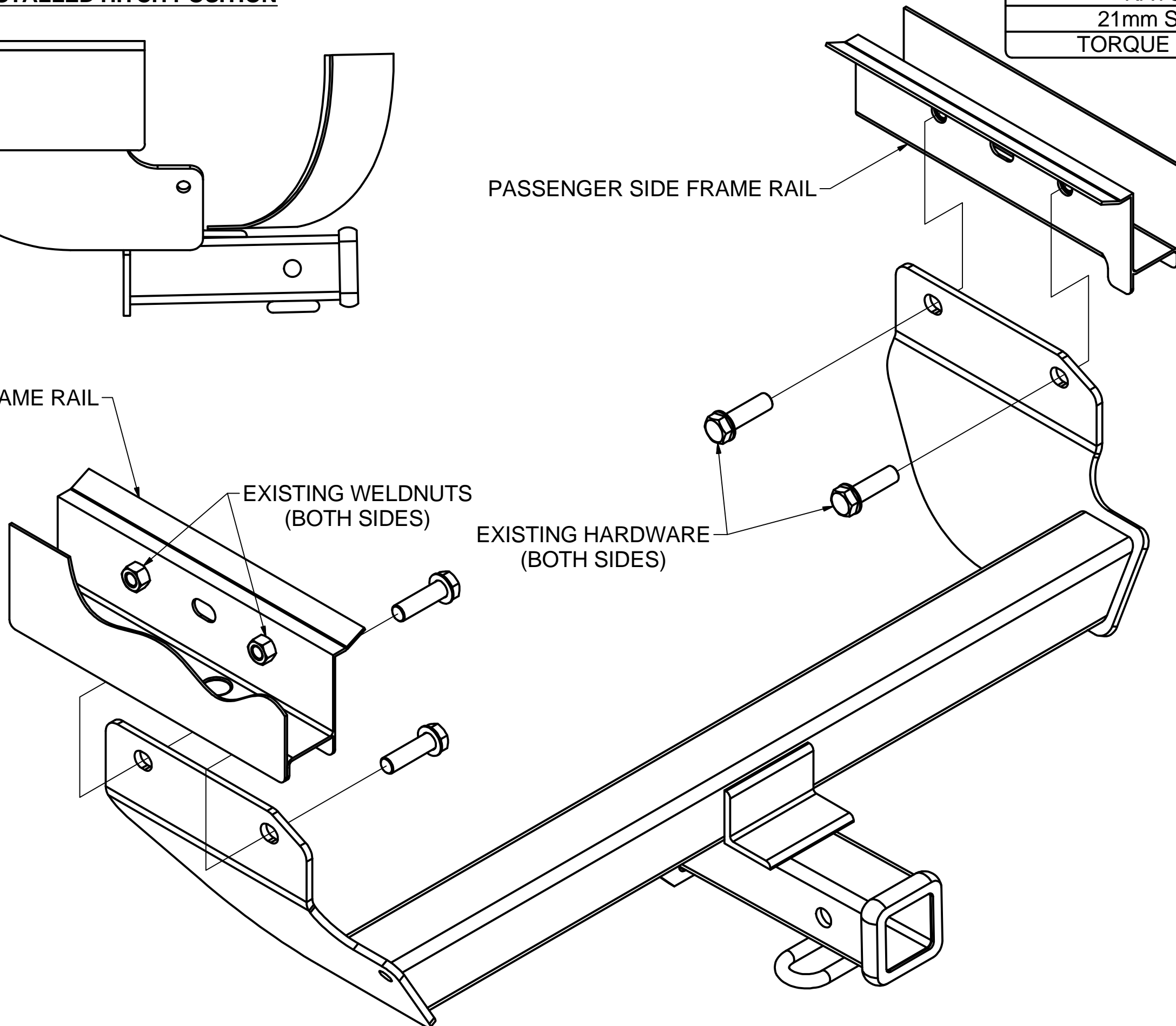

HITCH WEIGHT: 33 LBS.

INSTALL TIME

PROFESSIONAL: 10 MINUTES

NOVICE (DIY): 20 MINUTES

INSTALL NOTES:

- NO DRILLING REQUIRED

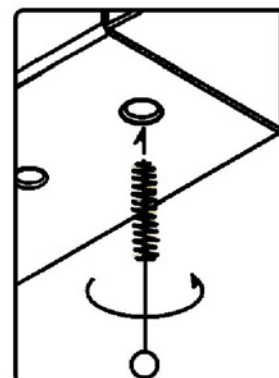

WELDNUT CLEANING

To remove debris from weldnuts in frame, spray lubricant or compressed air into hole. For heavy debris, use a small wire brush. (Be careful not to damage threads).

FRONT
↑
REAR

INSTALLATION STEPS

Note: If factory tow loop is present you will need to remove it prior to install.

1. Remove (4) existing M14 bolts. These bolts will be used for hitch installation.
2. Raise hitch into position and reinstall (4) M14 bolts. Note: Trim excess caulk on vehicle frame rails if it interferes with hitch installation.
3. Tighten all M14 hardware to 126 ft-lbs.

PERIODICALLY CHECK THIS RECEIVER HITCH TO ENSURE THAT ALL FASTENERS ARE TIGHT AND THAT ALL STRUCTURAL COMPONENTS ARE SOUND.

Keystone Automotive Operations Inc., warrants this product to be free of defects in material and/or workmanship at the time of retail purchase by the original purchaser. If the product is found to be defective, Keystone Automotive Operations Inc., may repair or replace the product, at their option, when the product is returned, prepaid, with proof of purchase. Alteration to, misuse of, or improper installation of this product voids the warranty. Keystone Automotive Operations Inc.'s liability is limited to repair or replacement of products found to be defective, and specifically excludes liability for incidental or consequential loss or damage. This product complies with safety specifications and requirements for connecting devices and towing systems of the state of New York, V.E.S.C.

11202017