

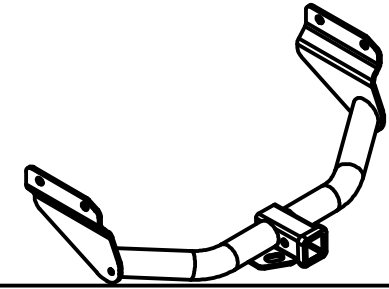

# Class III Receiver Hitch Part No. 69530C



**Fits: DODGE DURANGO, JEEP GRAND CHEROKEE**



GROSS LOAD CAPACITY WHEN USED AS A WEIGHT CARRYING HITCH: 6,000 LBS. TRAILER WEIGHT & 600 LBS. TONGUE WEIGHT.  
GROSS LOAD CAPACITY WHEN USED AS A WEIGHT DISTRIBUTION HITCH: 7,500 LBS. TRAILER WEIGHT & 750 LBS. TONGUE WEIGHT  
WARNING: \*\*\* DO NOT EXCEED VEHICLE MANUFACTURER'S RECOMMENDED TOWING CAPACITY. \*\*\*



### INSTALLED HITCH POSITION

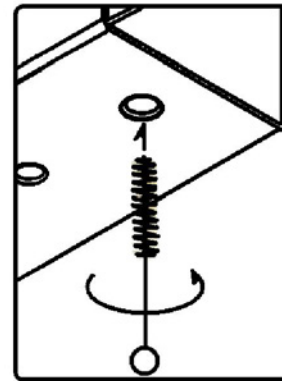
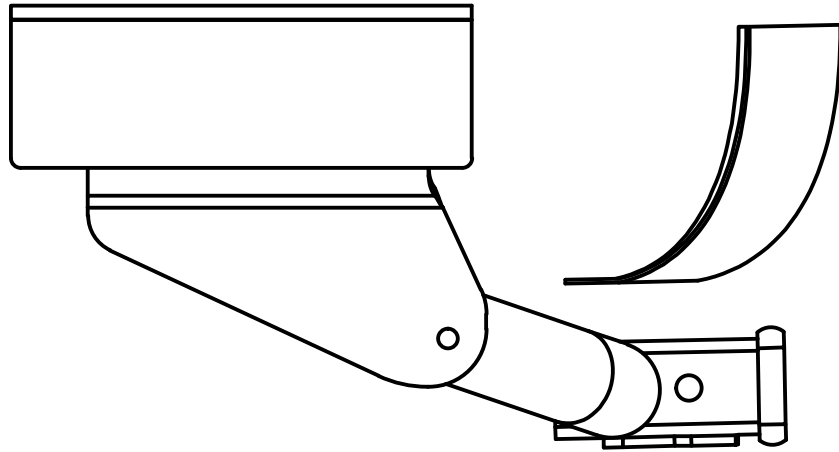

### WELDNUT CLEANING

To remove debris from weldnuts in frame, spray lubricant or compressed air into hole. For heavy debris, use a small wire brush. (Be careful not to damage threads).

### TOOLS REQUIRED

RATCHET
21mm SOCKET
TORQUE WRENCH
UTILITY KNIFE

### Diesel (DEF) Tank Fastener Locations

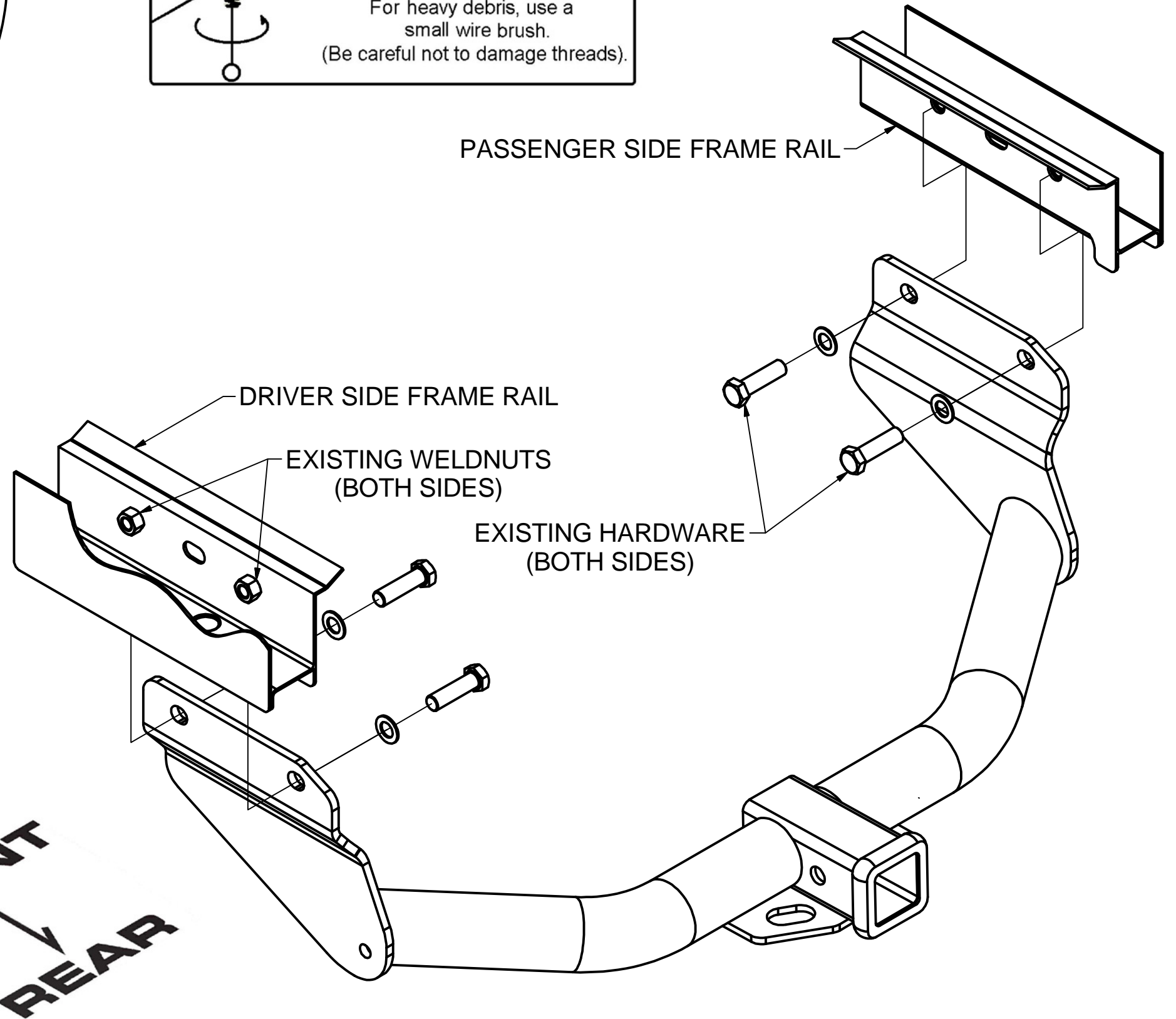
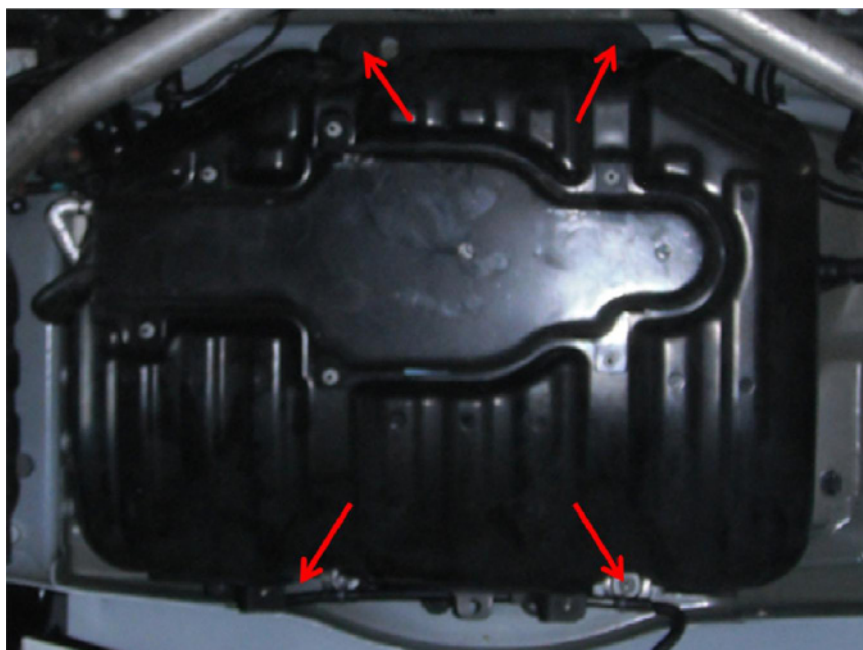

HITCH WEIGHT: 30 LBS.

#### INSTALL TIME

PROFESSIONAL: 10-30 MINUTES

NOVICE (DIY): 20-60 MINUTES

#### INSTALL NOTES:

- NO DRILLING REQUIRED
- DIESEL MODELS REQUIRE (DEF) TANK LOWERING

## INSTALLATION STEPS

### Diesel models only:

Due to the Diesel Exhaust Fluid (DEF) Tank location, it will need to be lowered to access the passenger side bolts. **It is highly recommended that the tank is well supported before removing the fasteners as the tank may weigh as much as 80 lbs.** Start lowering the tank by unclipping the electrical connection on the passenger side and sliding the clips off of the rear studs holding the tank. Using a 13mm socket, remove the rear stud posts and the 2 bolts on the front side of the tank. (See photo above) **DO NOT REMOVE THE FILLER PIPE FROM TANK.** The tank should be free to rotate slightly downward on the passenger side for access to the bolts/weld nuts.

**Note:** If factory tow loop is present you will need to remove it prior to install.

1. Remove existing M14 bolts. There will be (4) or (6) bolts depending on vehicle model. Retain (4) bolts for hitch installation. Return remaining bolts (if any) to vehicle owner.
2. Raise hitch into position and reinstall (4) M14 bolts. Note: Trim excess caulk on vehicle frame rails if it interferes with hitch installation.
3. Torque all M14 hardware to 126 lb-ft. Reinstall DEF tank if lowered on diesel models and reconnect electrical components. Torque DEF tank studs to 21 lb-ft and the DEF tank Hex Bolts to 24 lb-ft.

PERIODICALLY CHECK THIS RECEIVER HITCH TO ENSURE THAT ALL FASTENERS ARE TIGHT AND THAT ALL STRUCTURAL COMPONENTS ARE SOUND.

Keystone Automotive Operations Inc., warrants this product to be free of defects in material and/or workmanship at the time of retail purchase by the original purchaser. If the product is found to be defective, Keystone Automotive Operations Inc., may repair or replace the product, at their option, when the product is returned, prepaid, with proof of purchase. Alteration to, misuse of, or improper installation of this product voids the warranty. Keystone Automotive Operations Inc.'s liability is limited to repair or replacement of products found to be defective, and specifically excludes liability for incidental or consequential loss or damage. This product complies with safety specifications and requirements for connecting devices and towing systems of the state of New York, V.E.S.C.

11202017