



Assembly, Installation, Operation and
Maintenance Instructions
OEM 2-5/16" Gooseneck Ball

P/N: 33055

Dealer / Installer:	Provide a copy of these Instructions to the end user of this product. These Instructions provide important operating and safety information for proper usage of this product. Demonstrate the proper use of the product with the end user. Have the end user demonstrate that they understand the proper use of the product.
End User:	Read and follow all instructions included in this manual. Ask your Dealer / Installer for assistance if you do not understand the proper use of the product. Never remove any decals from the product.

APPLICATION:

- 2011 to 2017 Ford F250 / 350 – vehicle must have OEM 5th wheel/gooseneck Hitch Prep Package
- 2014 to 2017 Ram 2500 – vehicle must have OEM 5th wheel/gooseneck Hitch Prep Package
- 2013 to 2017 Ram 3500 – vehicle must have OEM 5th wheel/gooseneck Hitch Prep Package
- 2015 to 2017 GM 2500 / 3500 – vehicle must have OEM 5th wheel/gooseneck Hitch Prep Package
- 2016 to 2017 Nissan Titan – vehicle must have OEM 5th wheel/gooseneck Hitch Prep Package

DO NOT EXCEED Recommended towing limits. SEE VEHICLE'S OWNER'S MANUAL.

1. To install gooseneck ball; lift the handle and rotate it 90 degrees to unlock the gooseneck ball.
2. Install the gooseneck into the receiver portion of the truck.
3. Once installed; rotate & push down the handle to lock and secure the gooseneck ball. The gooseneck ball should not lift out of the gooseneck receiver and should rotate freely in the gooseneck receiver.

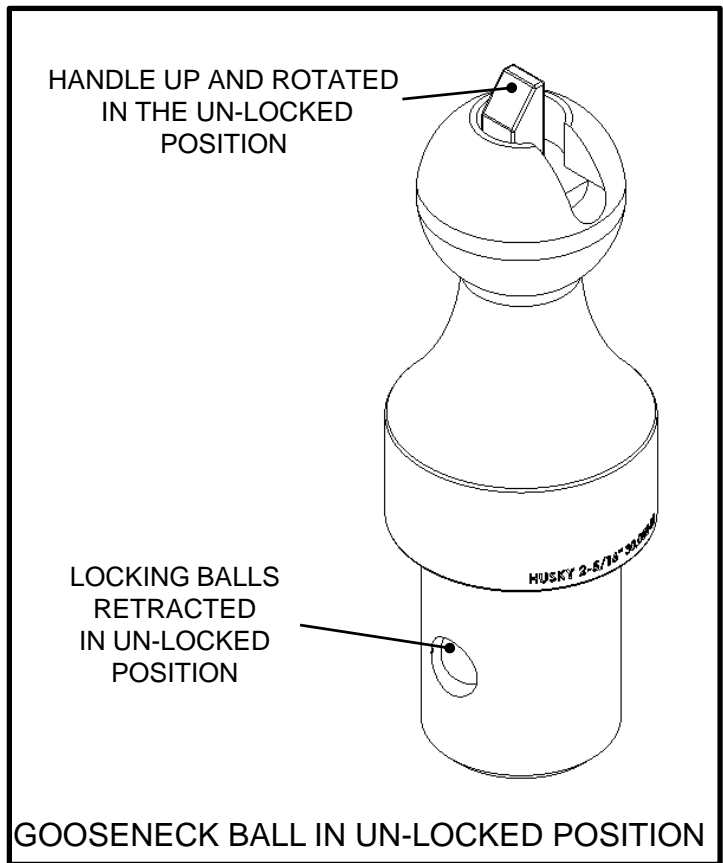
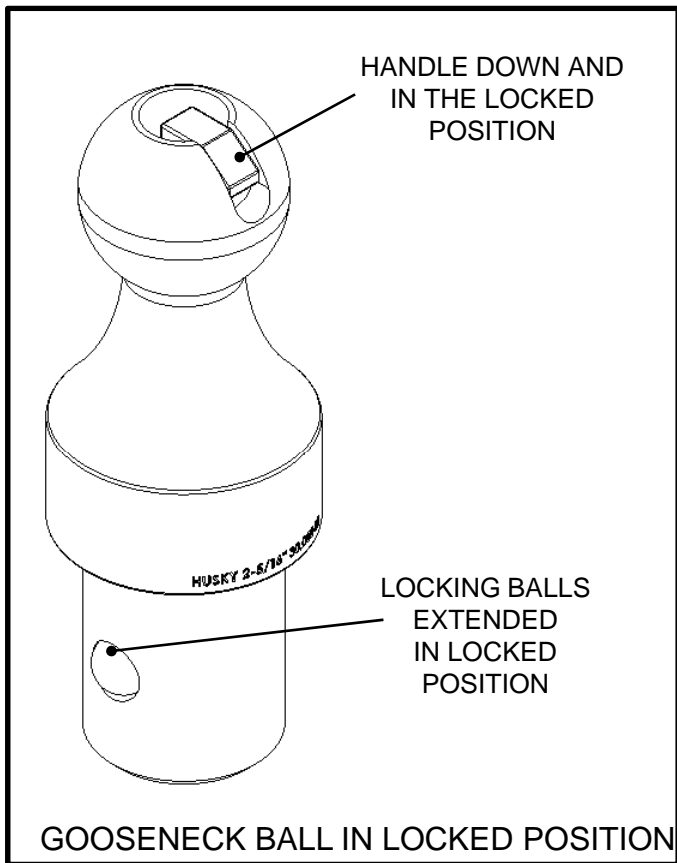

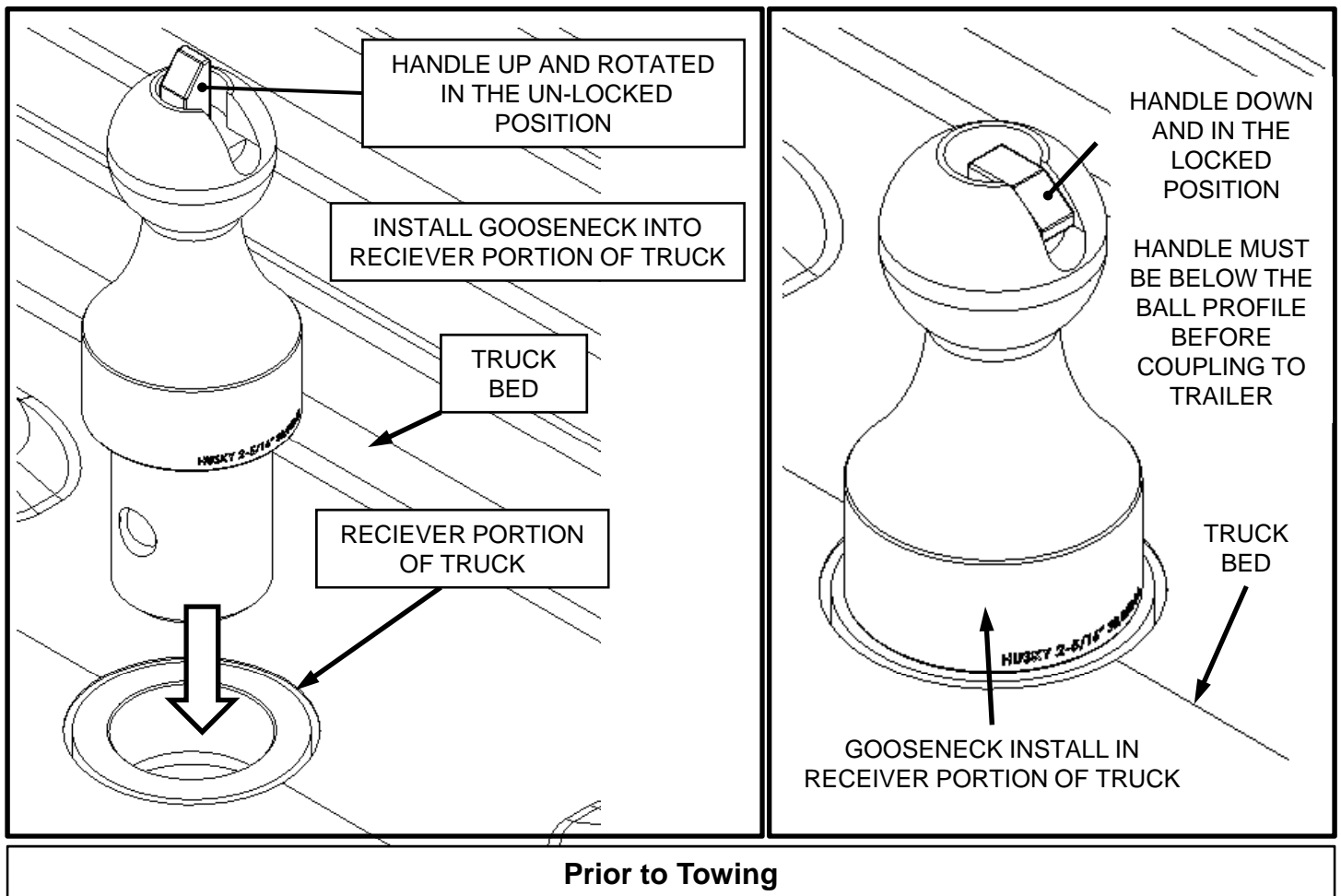

1. Be sure the gooseneck ball is secure and functioning properly and freely rotates in the gooseneck receiver.
2. Lubricate gooseneck ball before use.
3. Verify adequate turning clearance between truck cab and corner of trailer
4. Verify safety chains are secure before towing
5. Verify that the trailer weight does not exceed tow vehicle & gooseneck capacity
6. Verify brake lights & trailer brakes & brake away switches work properly
7. Perform a tug test on the truck and trailer before towing:
 - Connect and test power cables, attach emergency brake cable. With Trailer Landing Gear down, wheels chocked and the trailer brakes SET ON slowly pull forward to check security of gooseneck. Recheck connections
 - Remove the wheel chocks from the wheels of the 5th Wheel Trailer; Raise Trailer Landing Gear and double check that the hitch is properly attached to your tow vehicle.

TOWING TIPS

Driving Tow Vehicle

Good habits for normal driving need extra emphasis when towing a trailer. The additional weight of the trailer affects acceleration and braking. Extra time should be allowed for passing, stopping and changing lanes. Signal well in advance of a maneuver to let other drivers know your intentions. Severe bumps and badly undulating roads can damage your towing vehicle, hitch and trailer, and should be negotiated at a slow, steady speed. If any part of your towing system “bottoms out” or if you suspect damage may have occurred in any other way, pull over and make a thorough inspection. Correct any problems before resuming travel.

Turning and backing up present new problems-plan ahead. It is highly recommended that a spotter be used when backing up to alert the driver of possible obstacles and prevent jack knifing the trailer.

Towing a trailer will change your turning radius, the longer the trailer the larger radius turn.

Driving Conditions

When driving in conditions where the pavement is wet, icy, snowy, loose gravel, grass and dirt, reduce speed and do not make any sudden maneuvers. Allow ample distance/time for stopping and changing lanes. If possible, wait for road conditions to improve before driving.

Follow all state, local and provincial driving and towing laws in the location you are driving in.

Not following your tow vehicle, trailer, and Husky instructions/manuals can result in a fatal accident.

Check Your Equipment

Please refer to the MAINTENANCE section. Periodically check the condition of all your towing equipment and keep it in top condition.

Tire Inflation

Unless specified otherwise by the towing vehicle or trailer manufacturer, tires should be inflated to their manufacturer's towing recommendations.

Towing Vehicle and Trailer Manufacturers Recommendations

Review the owner's manual for your towing vehicle and trailer for specific recommendations, capacities and requirements.

Passengers in Trailers

Trailers should not be occupied while being towed. Most states enforce this regulation.

Trailer Lights, Turn Signals, Electric Brakes

Always hook up all of the trailer lights, electric brakes and break-away switch connection whenever trailer is being towed. Also periodically check functionality of all lights before towing and repair any problems as needed.

Remove Hitch When Not Towing

Remove hitch from receiver on towing vehicle when not towing a trailer to reduce chances of striking hitch on driveway or other objects, and reduce the chance of parts being stolen

Maintenance

Keep gooseneck ball lubricated when used.

Remove gooseneck ball from gooseneck receiver and store in clean, dry place when not in use.

Keep gooseneck receiver clean and lubricated.

At The Beginning of Every Towing Day:

Clean ball and coat ball lightly with grease.

If electric brakes are used ensure the emergency break away cable is attached to the tow vehicle.

Check to see that all electrical hook-ups are in working order and that the safety chains are securely connected.

Towing safely is the responsibility of the driver of the vehicle. Failure to tow safely can result in vehicle damage, bodily injury or death.

Warranty Terms:

10 Year Limited Warranty:

This warranty applies solely to Husky gooseneck manufactured by manufactured by DTS Mfg. for Husky Towing Products.

Husky Towing Products and DTS Mfg. make no guarantees or warranties for products not manufactured by DTS Mfg. Such products are covered solely under any applicable warranty of the manufacturer. It is always recommended that the operating instructions and guarantee instructions provided by the manufacturer are followed.

DTS Mfg. warrants its products to be free from manufacturing and material defects to the original purchaser for the length of warranty stated above from the date of retail purchase. If any products are found to have a manufacturing or material defect, the product will be replaced or repaired at the option of Husky Towing Products and DTS Mfg. with proof of purchase by the original purchaser. The original purchaser shall pay all transportation and shipping costs associated with the return of the defective product and the defective product shall become the property of DTS Mfg.

The Warranty applies to DTS Mfg. products used for individual and recreational purposes. Commercial usage of the DTS Mfg. products limits the warranty to 90-days from date of purchase.

The Warranty applies only to DTS Mfg. products which are found to be defective in manufacturing or material. This warranty does not apply to normal wear and tear of the finished placed on DTS Mfg. products.

Husky Towing Products and DTS Mfg. are not responsible for any labor costs incurred for removal or replacement of the defective product.

Husky Towing Products and DTS Mfg. are not responsible for repair or replacement of any product under the limited warranty where the product was improperly installed, misapplied, altered, abused, neglected, overloaded, misused or damaged as a result of an accident, including any use of the product not in accordance with all product operating and safety instructions.

Without limiting the generality of the foregoing, Husky Towing Products and DTS Mfg. shall under no circumstances be liable for any incidental or consequential loss or damage whatsoever arising out of, or in any way relating to any such breach of warranty or claimed defect in, or non-performance of the products. Some states do not allow the exclusion or limitation of incidental or consequential damages, so the above exclusion or limitation may not apply to you.

This limited warranty gives you specific legal rights, and you may also have other rights that vary from state to state.