



# Assembly, Installation, Operation and Maintenance Instructions

**P/N: 33000**

## RAM UPRIGHTS

<b>Dealer / Installer:</b>	Provide a copy of these Instructions to the end user of this product. These Instructions provide important operating and safety information for proper usage of this product. Demonstrate the proper use of the product with the end user. Have the end user demonstrate that they understand the proper use of the product.
<b>End User:</b>	Read and follow all instructions included in this manual. Ask your Dealer / Installer for assistance if you do not understand the proper use of the product. Never remove any decals from the product.

**WARNING!** Never exceed the towing capacity of the tow vehicle.

Use only the supplied bolts, nuts, and washers to install this kit. All nuts and bolts are Grade 5 unless specified otherwise.

**APPLICATION:**  
 Ram 2500 years 2014 to Current – vehicle must have OEM 5<sup>th</sup> wheel/Gooseneck Hitch Prep Package  
 Ram 3500 years 2013 to Current – vehicle must have OEM 5<sup>th</sup> wheel/Gooseneck Hitch Prep Package

**This kit is to be used ONLY with Husky kits:**  
 32998 (HUSKY 16KW/26W CROSSMEMBER KIT), 32998 REQUIRES THE PURCHASE OF 31581 (16KW) OR 31578 (26KW)  
 32999 (HUSKY 16KS CROSSMEMBER KIT), 32999 REQUIRES THE PURCHASE OF 31453

**TOOLS**

- 1-1/16" Socket & Open End Wrench
- 5/8" Allen Head Wrench or Socket
- 1-1/2" wrench or adjustable wrench
- Torque Wrench capable of 250 ft.lbs.

PARTS LIST		
ITEM NO.	DESCRIPTION	QTY.
1	UPRIGHT	2
2	FRONT ADAPTOR	2
3	FRONT T-BOLT	2
4	REAR ADAPTOR	2
5	REAR T-BOLT	2
6	1"-14 JAM NUT	4
7	TAB WASHER	4
8	HANDLE #1	2
9	HANDLE #2	2
10	3/16" LOCK PIN	8
11	3/4"-10 X 1-3/4" SOCKET HEAD CAP SCREW	4
12	3/4" SPRING LOCK WASHER	4
13	1MM SHIMS	4
14	2MM SHIMS	4
15	INSTRUCTIONS	1

1. The following instructions should be used to mount the fifth wheel. Care and attention to detail will ensure a quick quality installation. Check parts against parts list to become familiar with parts in kit.

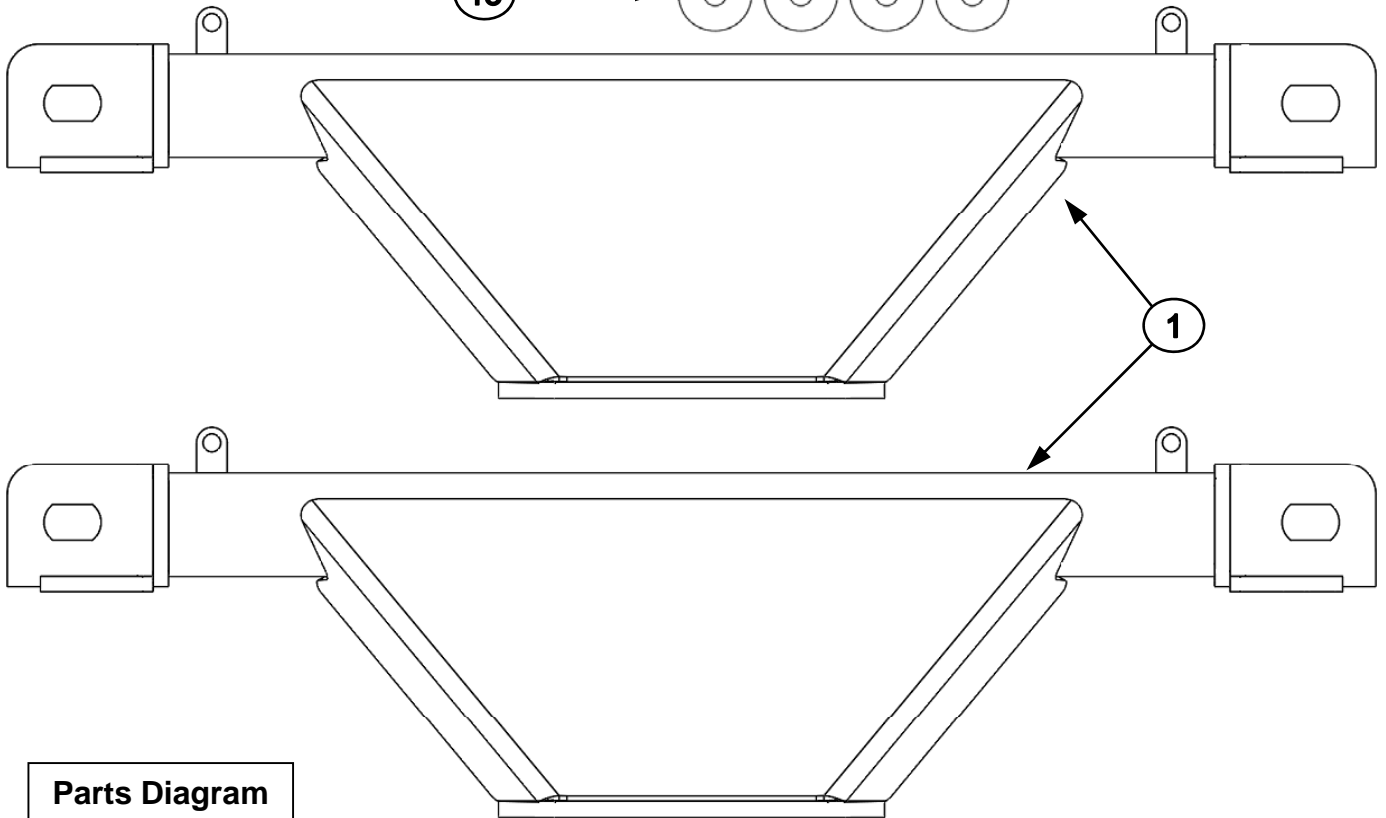
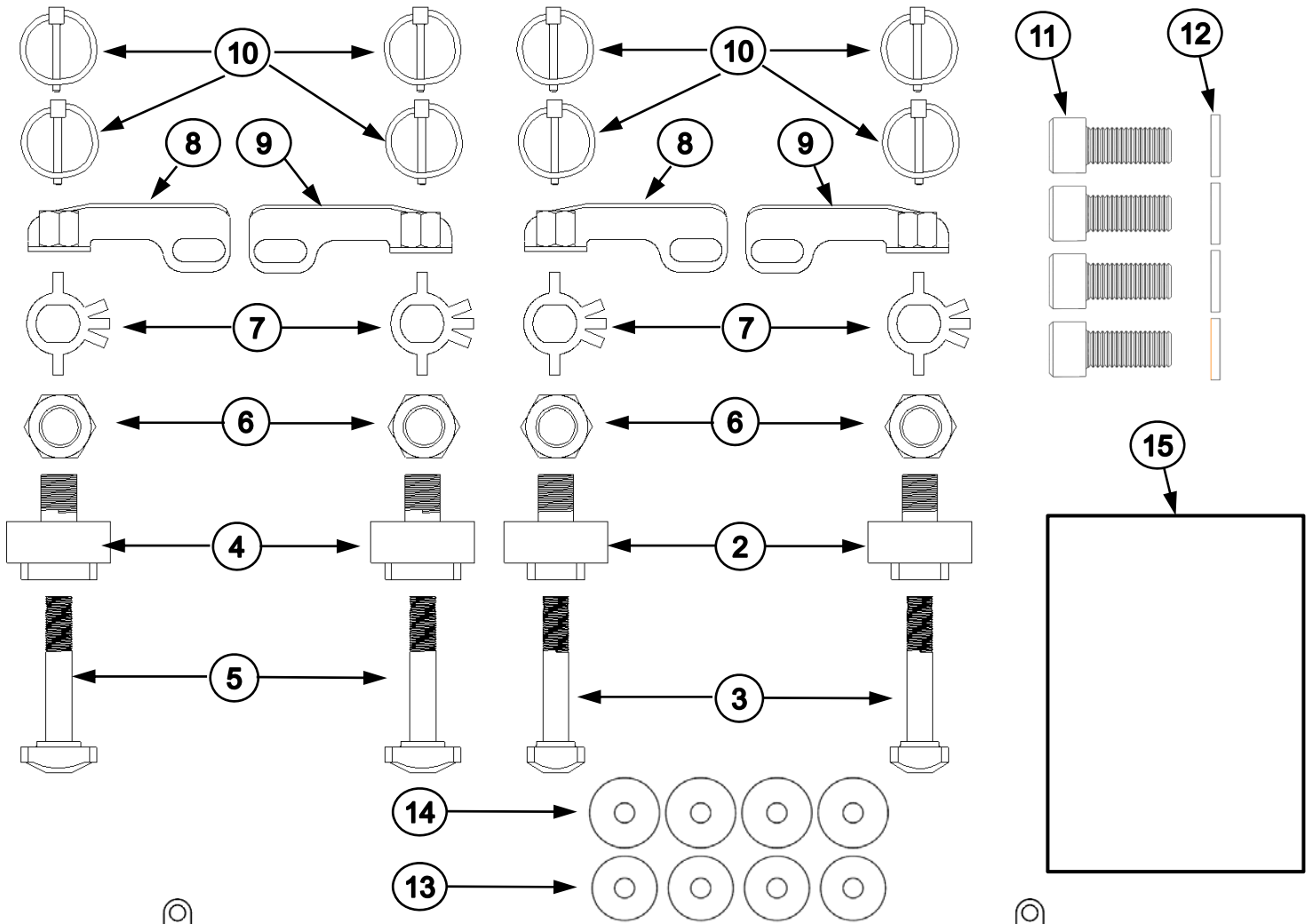

**Parts Diagram**

**WARNING:**

If the truck is raised, be sure that the truck is properly blocked and restrained to prevent the truck from falling. Failure to do so may result in the truck suddenly falling, causing death or serious injury.

**CAUTION:**

These instructions are guidelines only. Actual installation is the responsibility of the installer and the owner. Always measure truck and trailer before installing hitch to be sure that there is clearance at the cab and at the bumper to allow for turns.

**WARNING**

Failure to follow ALL of these instructions may result in death or serious injury

**WARNING**

This product is NOT to be used with rotating pin boxes or pin boxes that require a “wedge”; such as the REESE Sidewinder, REESE Revolution, 5<sup>th</sup> Airborne Sidewinder. Use of these products may damage this product and will void the warranty.

**NOTICE**

Husky recommends to always drive the king pin into the hitch throat and not drop the king pin from above into the hitch head to avoid incorrect hook-ups. Please read Operating Instruction to understand how this important Safety Feature operates.

**Refer to instructions: 32998 & 32999 for proper installation of those products.**

2. Attach the front adaptors (#2) and rear adaptors (#4) to uprights (#1) using the tab washers (#7) & 1"-14 jam nuts (#6). The tab washers should face outward for easy access. This will be helpful later in these instructions. **ONLY HAND** tighten jam nut. Repeat assembly for **BOTH** uprights. Be sure that the adaptors are installed on the appropriate ends. **Drivers side shown; passenger side is the opposite.**

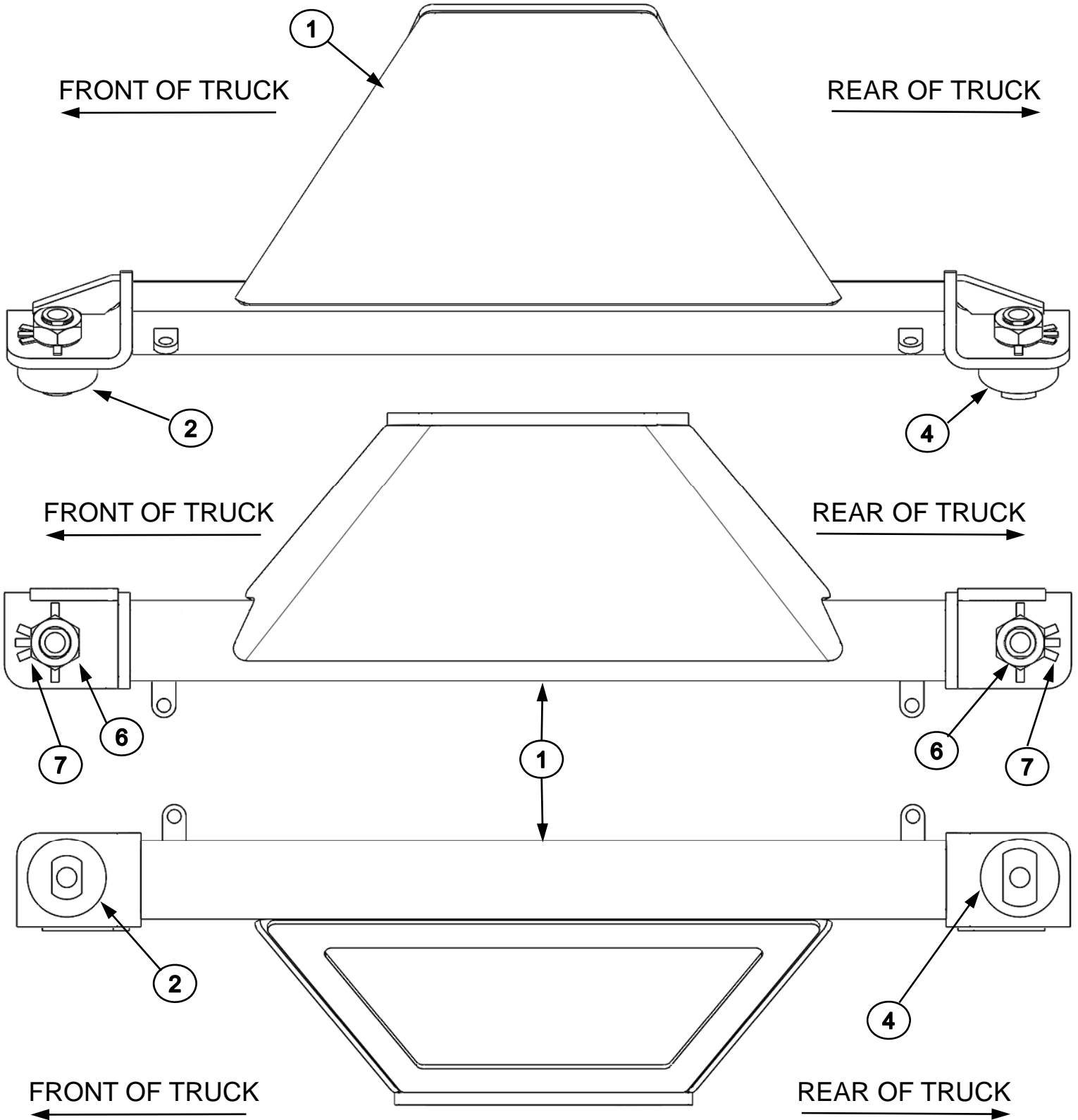

3. Attach front T-bolts (#3) and rear T-bolts (#5) and handles 1(#8) and handles 2 (#9) and 3/16" lock pins (#10) to the adaptors (#2 & #4) and uprights (#1) from Step 2. Thread the T-bolts into the handles completely but do NOT overtighten; you will possibly need to adjust them later to fit the Ram 5<sup>th</sup> Wheel adaptor installed in your truck from the factory. The 3/16" lock pin MUST line up and install easily into the hole of the T-bolts. Repeat assembly for BOTH uprights.

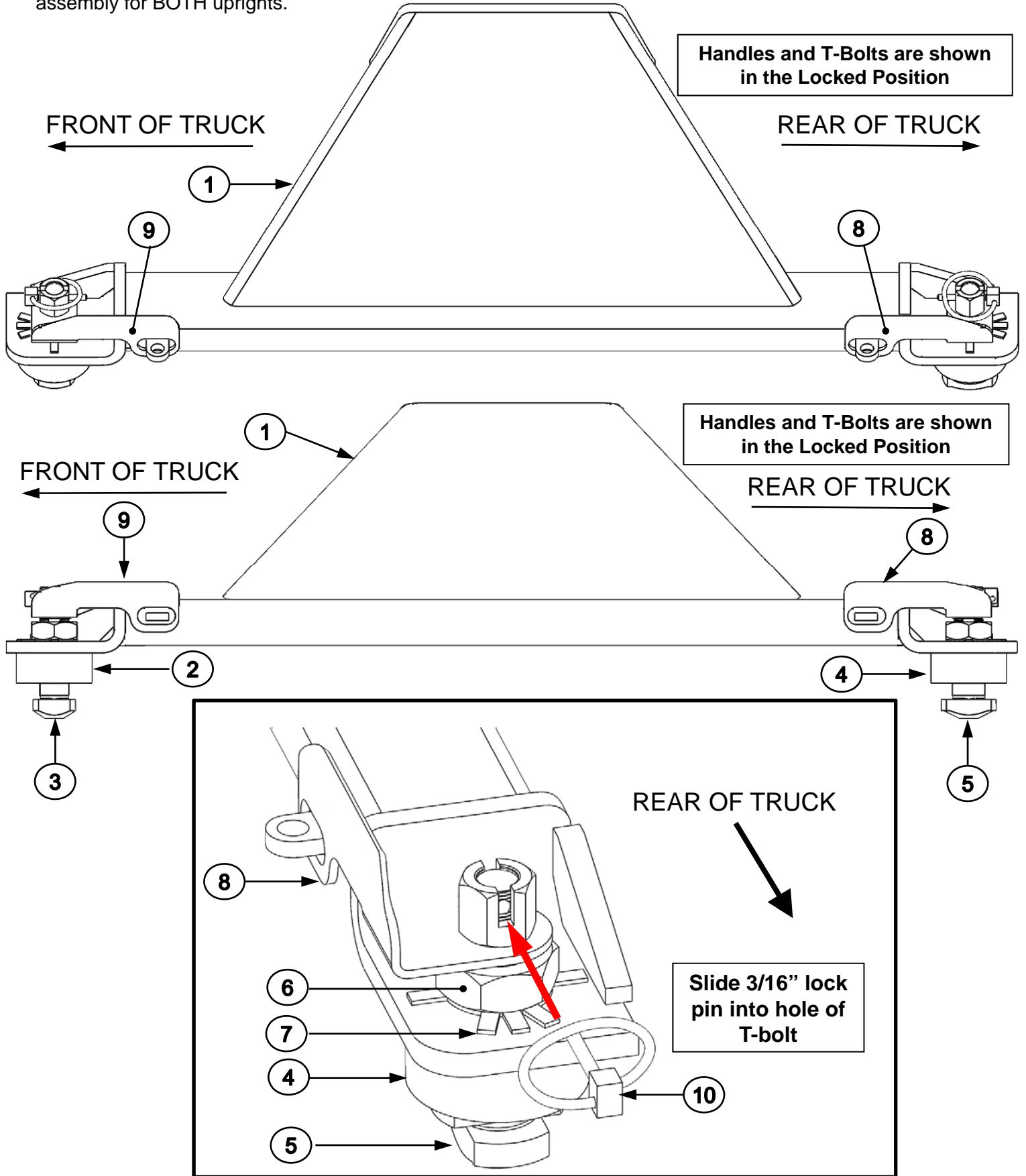

4. Place both uprights into Ram 5<sup>th</sup> Wheel adaptor installed in your truck from the factory. The handles and T-bolts must be rotated into the Un-locked position.

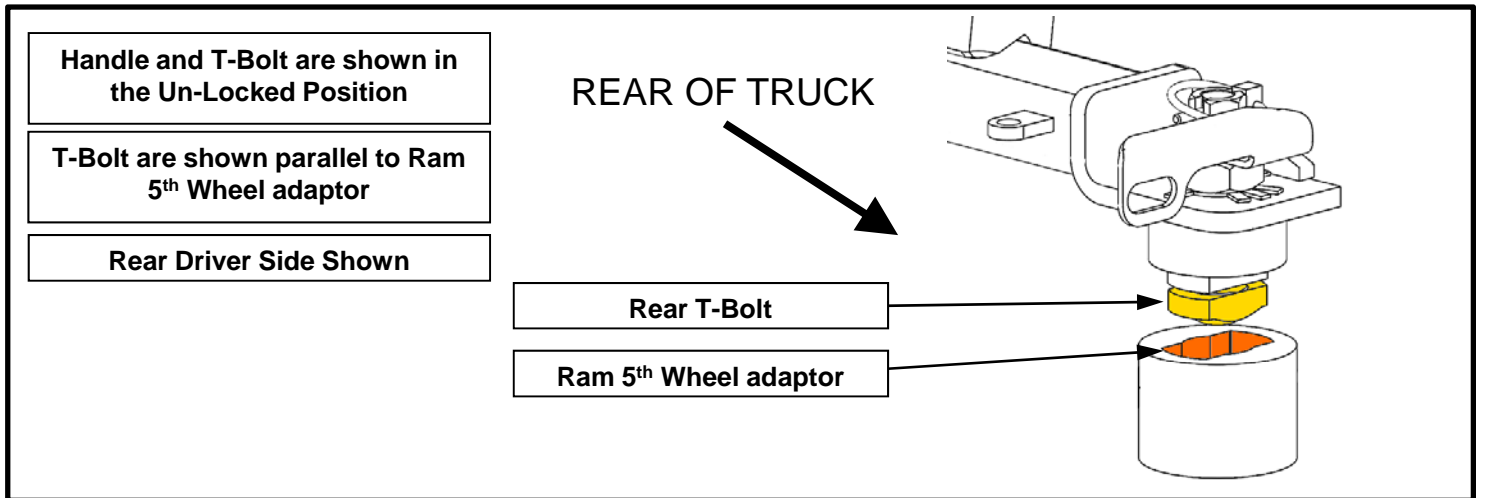
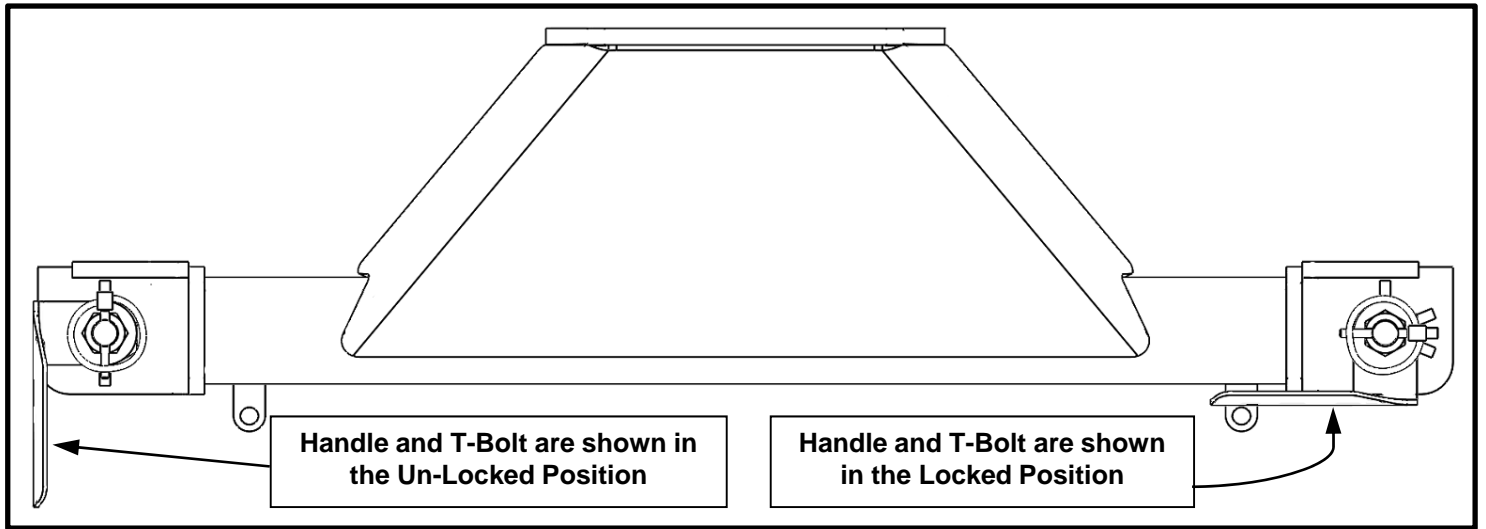
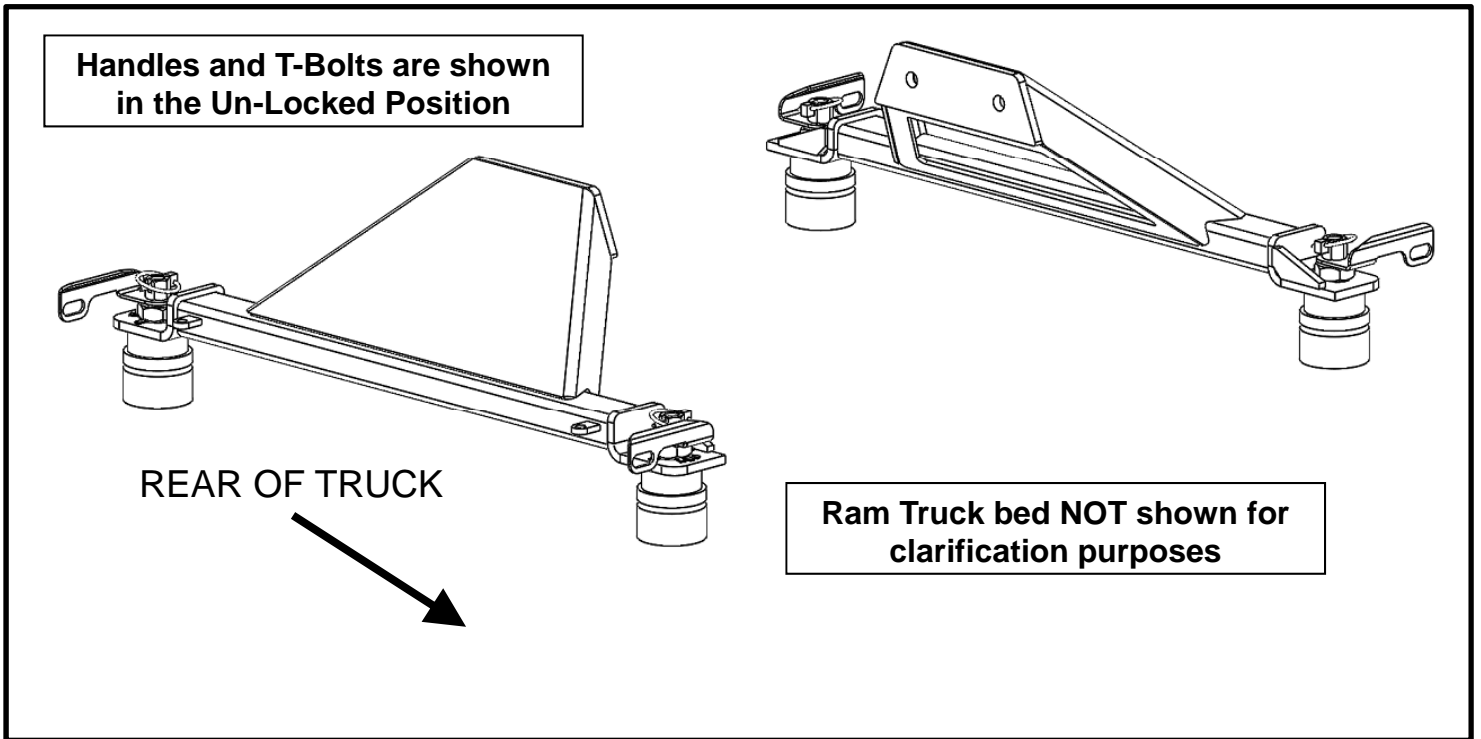

5. Once uprights are installed; turn handles and into the locked position. This may require adjusting the T-bolts for a looser or tighter fit.

**Handles and T-Bolts are shown in the Locked Position**

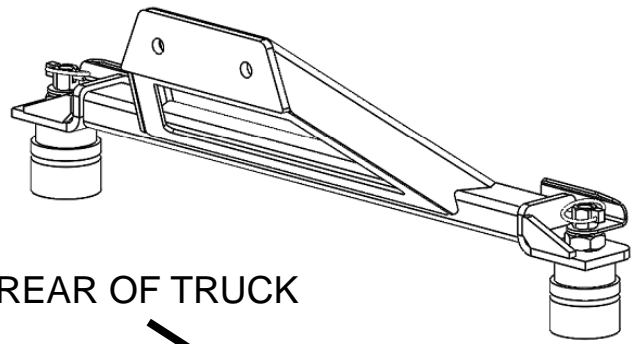
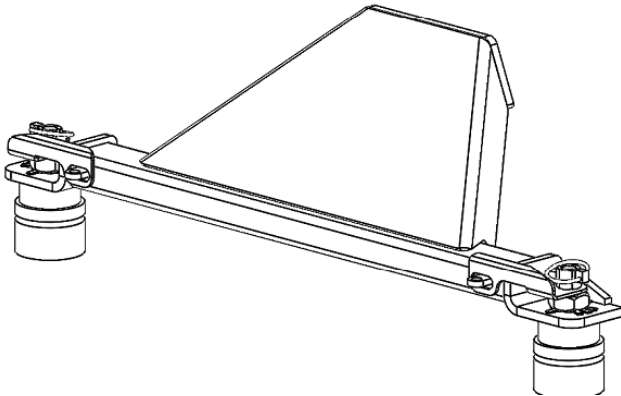

REAR OF TRUCK

6. Install the cross member from kit 32998 or 32999 to uprights (#1) using the 3/4"-10 bolts (#11) and 3/4" lock washers (#12). Kit 32998 shown below as an example; kit 32999 installs similarly.

**Handles and T-Bolts are shown in the Locked Position**

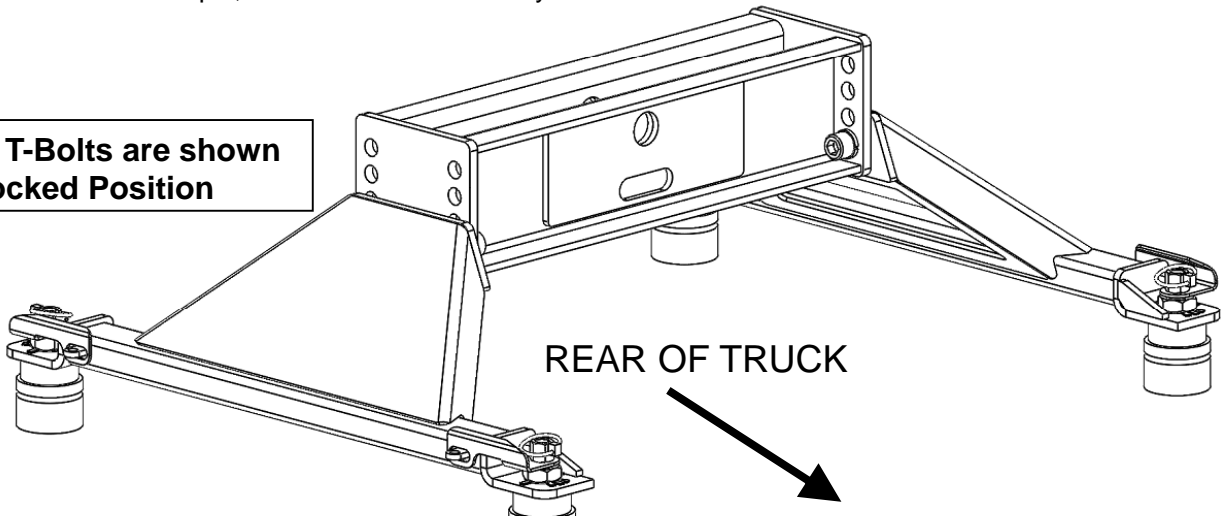

REAR OF TRUCK

6A: Some trucks are a little wider than others. This **MAY** require the use of shims. Align the shim(s) with the 3/4"-10 bolts (#11) Place shims between cross This kit is supplied with 1mm (#13) and 2mm (#14) shims. Use the shims as needed. Use the shims as pairs; if you use a 1mm shim on the front bolt, use a 1mm shim on the rear bolt. Same for the 2mm shims. You can use one 1mm sham and one 2mm shim per bolt if needed.

**Do not use more than 2 shims per bolt.**

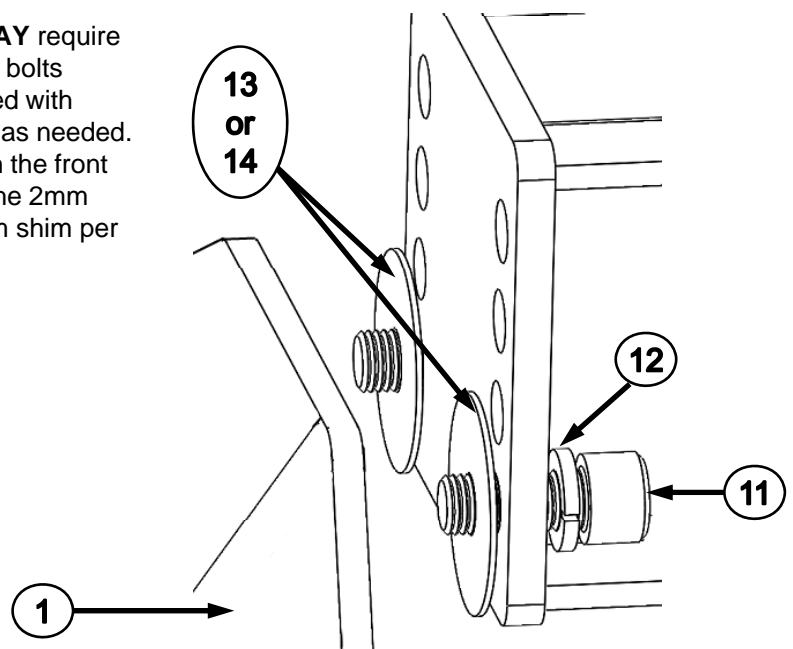

7. Once the crossmember is installed; make sure the adaptor (#2) sits FLAT with the Ram 5<sup>th</sup> Wheel Adaptor at ALL 4 contact locations. Torque all four ¾"-10 bolts (#11) to 250 ft.lbs.

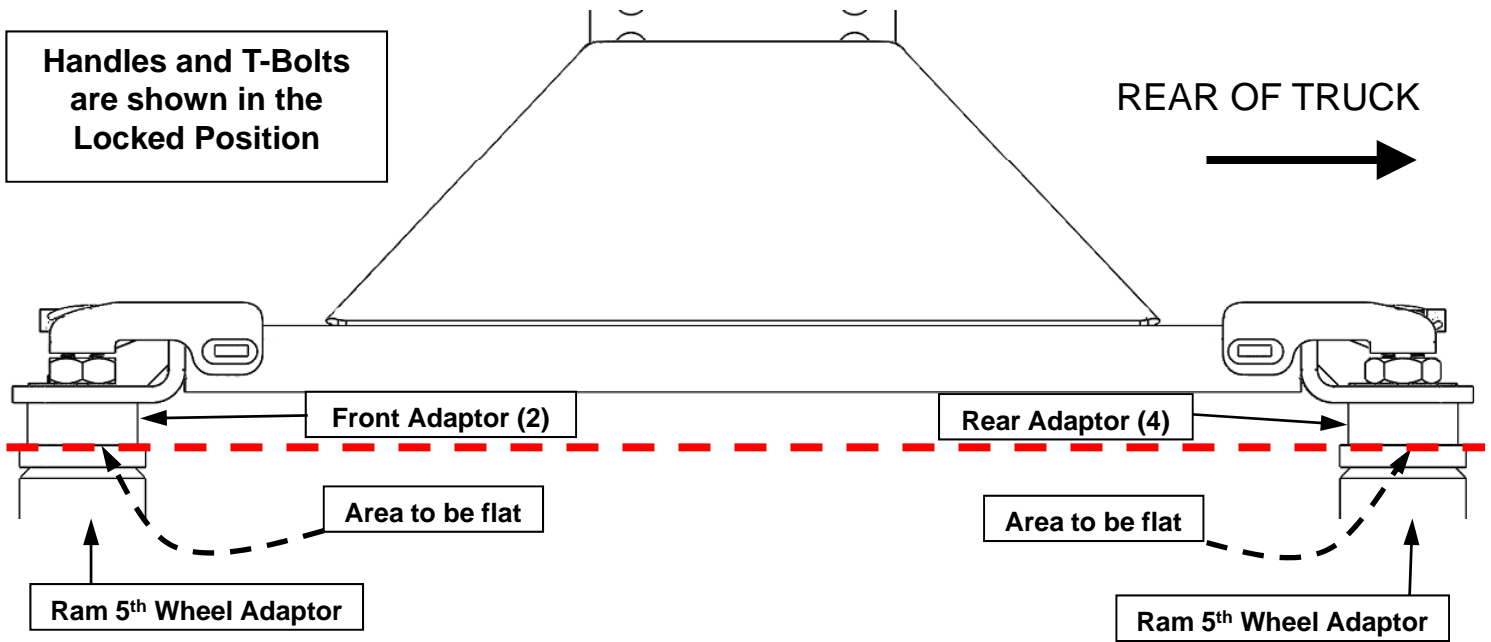

8. Rotate handles to the locked and unlocked positions. All 4 handles should rotate easily. Check to be sure that hitch assembly (uprights & crossmember) do NOT "rock" back and forth easily and that the adaptors (2) remain flat with the Ram 5<sup>th</sup> wheel adaptor. If the handles do not rotate easily OR if the hitch assembly "rocks" and does not stay flat; you need to adjust the T-bolts up or down by rotating them in the handles. We recommend you do this in half turn increments. Plus, this may take a few times to get adjusted correctly. All trucks are not made the same and require different amounts of adjustment. **Be PATIENT.**
9. Rotate handles to the unlocked position and remove hitch assembly (uprights & crossmember) from the Ram 5<sup>th</sup> wheel adaptors. IF the hitch assembly does NOT remove easily; loosen the 1" jam nuts (#6) and adjust the adaptors (#2 & #4) so that the hitch assembly easily removes. Re-tighten 1" jam nuts.
10. Once the hitch assembly removes easily, the handles rotate easily AND there is no "rock" in the hitch assembly with the Ram 5<sup>th</sup> Wheel adaptor you can tighten the 1" jam nuts with an adjustable wrench until tight.
11. Bend 1 of the tabs on each of the tab washers (#5) up and against the side of the jam nut. This will keep the 1" jam nut from loosening.

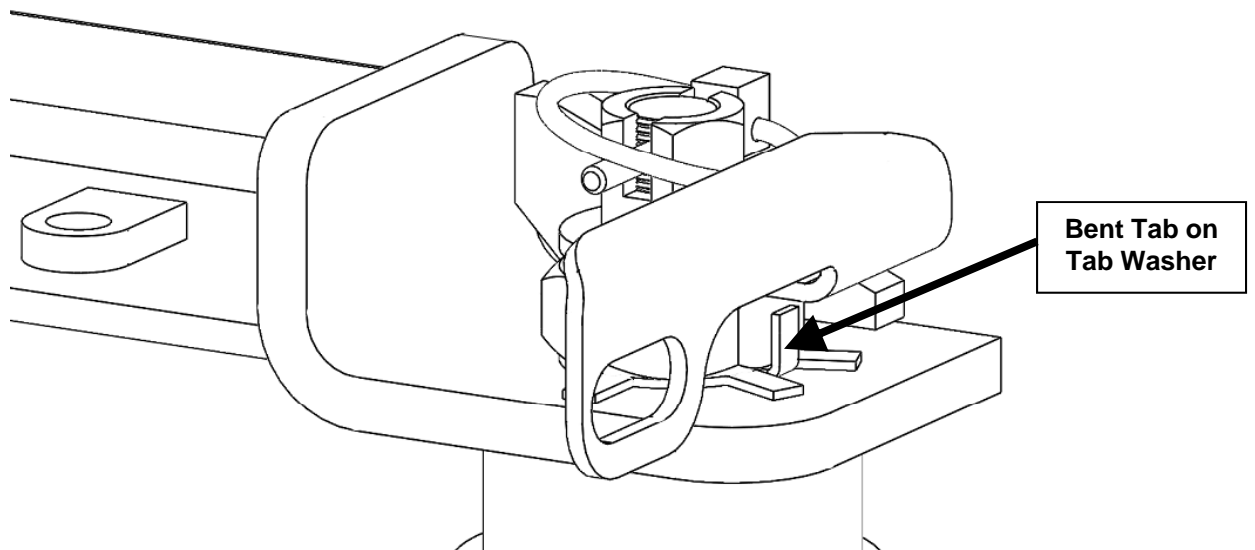



12. Finally, install the 3/16" Lock pins (#10) through the handles and the uprights.

**WARNING: NEVER TOW WITHOUT LOCKING THE 5<sup>TH</sup> WHEEL HITCH HANDLES WITH EITHER THE PROVIDED 3/16" LOCK PINS OR A PAD LOCK**

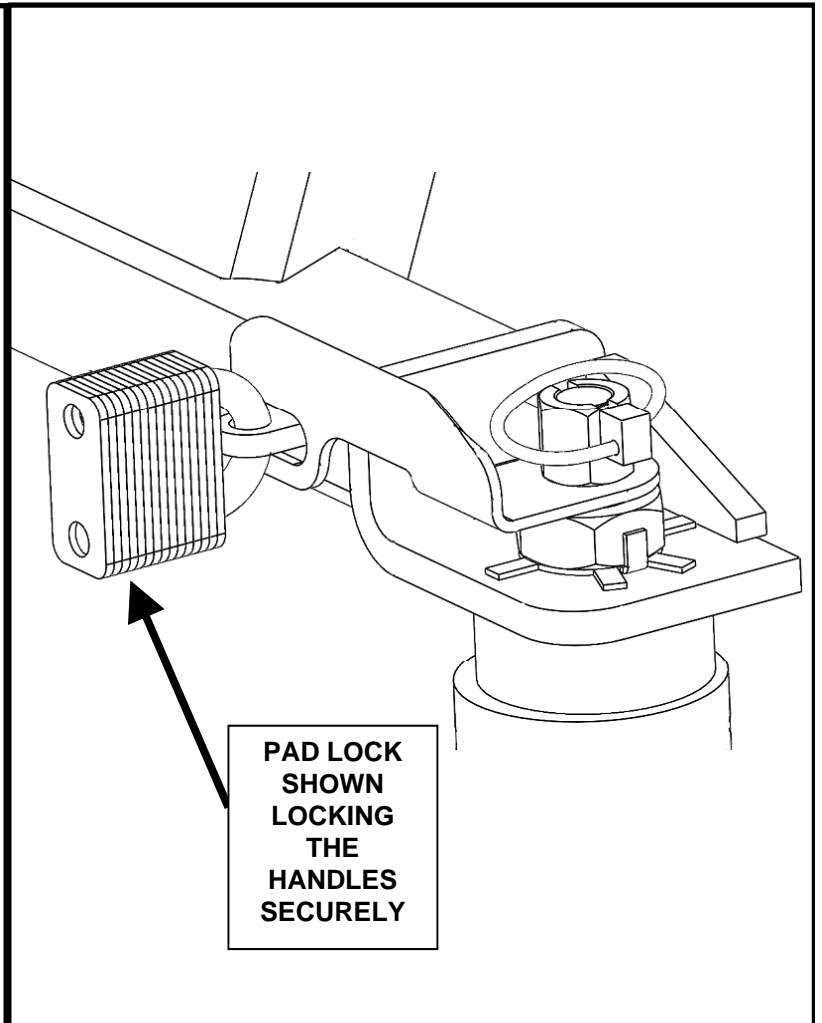
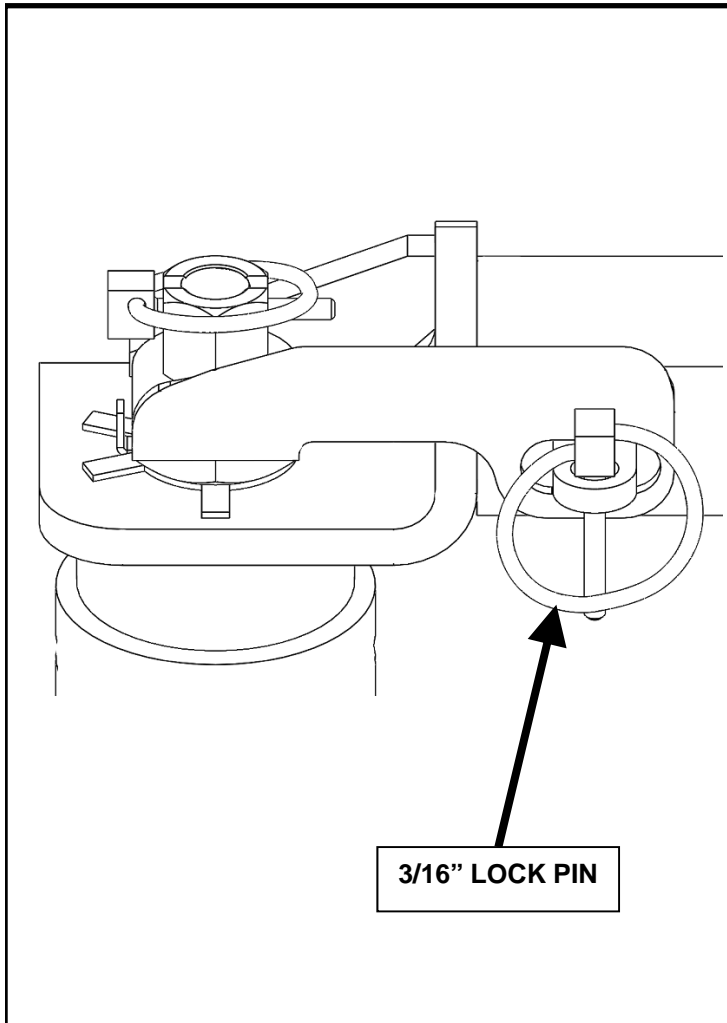
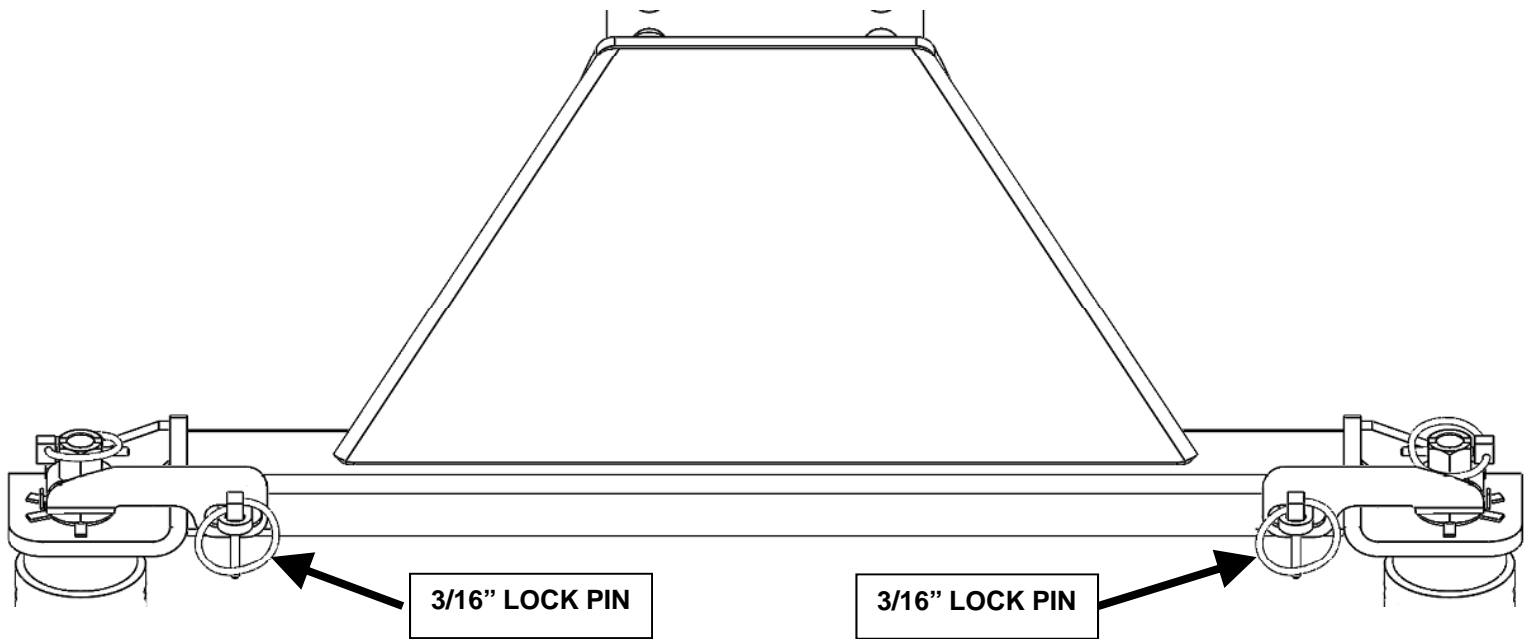

# Preparing For First Use

1. Verify that the cross member is set at the proper height to provide a minimum of 6" clearance between the bottom of the trailer nose and the top of the truck bed sides, and allows for a level-towing attitude of the 5th Wheel Trailer (See Figure 1 below).

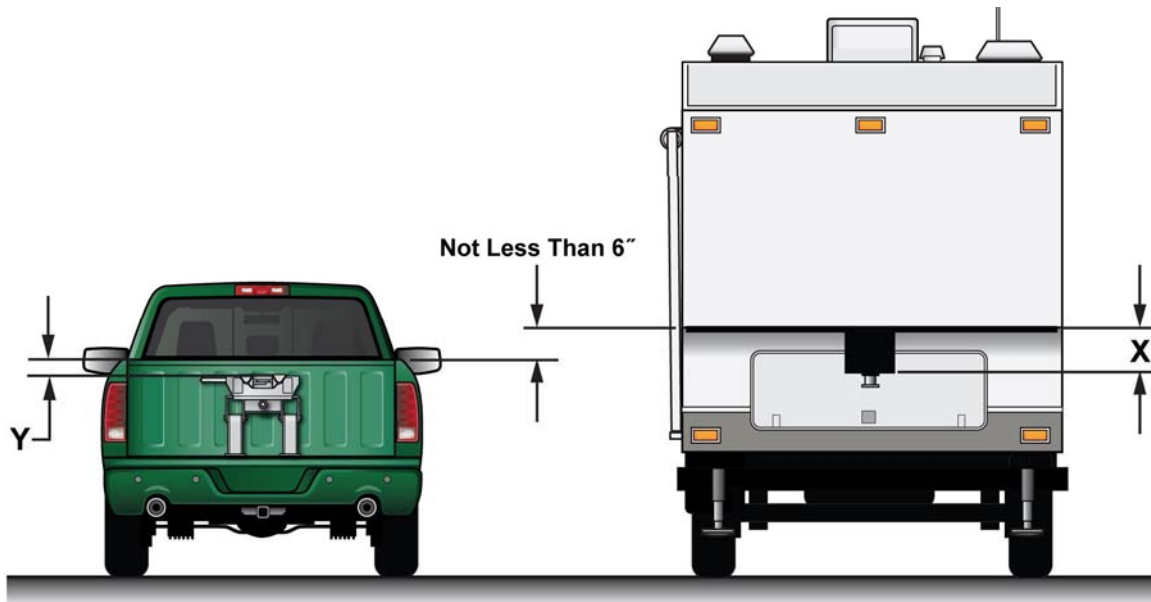

2. With top face of head level measure up to top of pickup box (dimension Y in Figure 1). On the trailer measure up from the face of the pin box to the underneath of the trailer (dimension X in Figure 1). Measurement X less measurement Y gives the amount of clearance between the top of the pickup box and the underneath of the trailer. At a minimum this should be 6", if the trailer and tow vehicle are going off-road then this needs to be 8" to 10".

**If this dimension is less than 6" DO NOT USE THIS TRAILER WITH THIS TOW VEHICLE. Severe damage may occur to both the pickup box and the trailer.**

3. If necessary, adjust the cross member to the proper height, ensuring the fasteners are re-torqued to 250 ft.lbs.
4. Ensure the 5th Wheel Trailer wheels are blocked front & rear & that the rear stabilizer jacks are fully retracted.
5. Also make sure the 5<sup>th</sup> Wheel Trailer landing leg feet are on a stable surface.
6. With hitch head level, set trailer king pin box 1/2" to 1" below hitch so trailer will ride up and onto hitch. Back Up the truck under the trailer so the king pin enters the hitch.

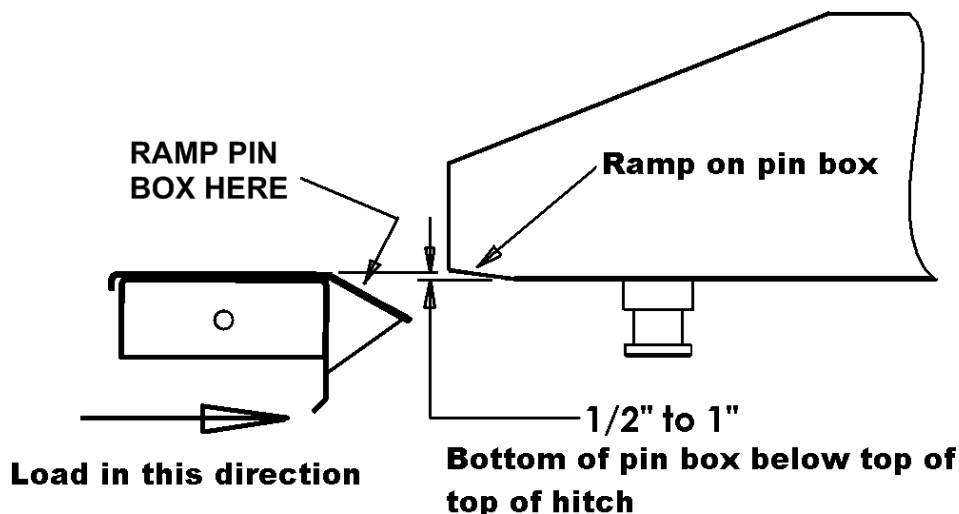

7. Open the handle to your 5<sup>th</sup> wheel according to the instructions provided to that specific product.
8. Slowly back the truck so that the bottom plate of the king pin box slides onto the 5th wheel plate & the king pin slides fully into the throat of the hitch head. Set the parking brake of the truck & place the transmission into park.
9. Visually verify the slide bar has closed behind the king pin and the king pin box is resting on the 5th wheel plate. Positively lock the slide bar by rotating the handle clockwise so the handgrip is pointing straight down at the bed of the truck. The red indicator sleeve on the handle shaft should not be visible when correctly hitched up and the green indicator shaft should be protruding from the side of the hitch head.

**Warning!** Never back the tow vehicle under the trailer king pin and then lower the king pin into the hitch. This will result in high pinning and will result in hitch damage and possible vehicle damage, injury or death!

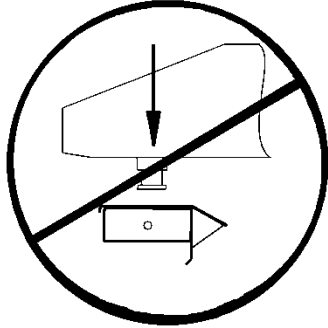

**NEVER LOWER THE TRAILER  
ONTO THE HITCH**

**NEVER LOWER THE KING PIN INTO THE HITCH USING THE TRAILER JACKS. THIS IS A VERY DANGEROUS PRACTICE AND WILL RESULT IN THE KING PIN SITTING ON TOP OF HITCH INSTEAD OF INSIDE. THE TRAILER COULD THEN BECOME DETACHED FROM THE TRUCK DURING TOWING CAUSING SERIOUS DAMAGE AND POSSIBLY INJURY OR DEATH.**

10. **Before towing perform a tug test as follows:** Ensure the landing gear of the 5th Wheel Trailer are extended to the ground, chock the tires, and attach the electrical & breakaway connectors to the proper receptacles in accordance with your 5th Wheel Trailer owner's manual. Then apply the trailer brakes, and slowly try to pull the trailer forward. The trailer should prevent the truck from moving.
11. Remove the blocks from the wheels of the 5th Wheel Trailer; fully retract the trailer jacks and double check that the hitch is properly attached to your tow vehicle.

## Uncoupling Your Trailer

1. Block your 5th Wheel Trailer wheels front & rear.
2. If necessary, start your truck & back up against the king pin to relieve pressure on the slide bar. Set the parking brake, put the transmission into park and then turn off your vehicle.
3. Extend the landing gear of the 5th Wheel Trailer until the weight of the 5th Wheel Trailer is just off of the 5th wheel plate of the hitch. Do not exceed 1/16" gap between the bottom plate of the king pin box and the tabletop of the hitch. **Caution: Raising the 5th Wheel Trailer too high while still connected can damage the hitch head as well as components of your 5th Wheel Trailer. Do not extend the rear stabilizers of the 5th Wheel Trailer prior to or during uncoupling.**
4. Disconnect the electrical and breakaway connectors in accordance with your 5th Wheel Trailer owner's manual. With the rubber grip of the handle pointing straight down towards the bed of the truck, pull it straight out and then rotate it straight up to lock the handle in the out position.
5. You are now ready to pull your truck slowly away from the 5th Wheel Trailer..



**DO NOT TRIP THE HITCH MECHANISM BY HAND AS THIS CAN RESULT IN INJURY . IN NORMAL OPERATION LEAVE THE HITCH OPEN UNLESS IT IS COUPLED TO A TRAILER.**

**ALWAYS PULL ON THE HANDLE TO OPEN THE HITCH BEFORE COUPLING THE TRAILER.**

# Maintenance

1. After coupling, always visually check that the slide bar or the jaw has closed completely across the rear of the king pin and that the indicators are working properly.  
**IMPORTANT! All indicating features should be work when you are done hitching up for travel.**
2. After the first 100 miles, and at least once a year thereafter, inspect all bolts for proper tightness. Re-tighten nuts if needed.
3. Once or twice a week when traveling, apply a few drops of lubricant to the pivot areas of the hitch.
4. Once or twice a year, apply a light coating of wheel bearing grease to the surfaces of the slide bar that holds the king pin in place. For best results, apply the grease with the slide bar or jaw surfaces of the 5<sup>th</sup> wheel in the closed position.

**Caution: The slide bar & jaws can close with heavy force. Use extreme care to keep fingers, hands, extremities & clothing out of the path of the slide bar. Failure to do so could result in severe injury.**

5. Periodically inspect your product for wear or damage.
6. Husky Towing Products recommends the use of a lube disc, contact your local Husky dealer to purchase one.

## **TOWING TIPS**

### **Driving Tow Vehicle**

Good habits for normal driving need extra emphasis when towing a trailer. The additional weight of the trailer affects acceleration and braking. Extra time should be allowed for passing, stopping and changing lanes. Signal well in advance of a maneuver to let other drivers know your intentions. Severe bumps and badly undulating roads can damage your towing vehicle, hitch and trailer, and should be negotiated at a slow, steady speed. If any part of your towing system “bottoms out” or if you suspect damage may have occurred in any other way, pull over and make a thorough inspection. Correct any problems before resuming travel.

Turning and backing up present new problems-plan ahead. It is highly recommended that a spotter be used when backing up to alert the driver of possible obstacles and prevent jack knifing the trailer.

Towing a trailer will change your turning radius, the longer the trailer the larger radius turn.

### **Driving Conditions**

When driving in conditions where the pavement is wet, icy, snowy, loose gravel, grass and dirt, reduce speed and do not make any sudden maneuvers. Allow ample distance/time for stopping and changing lanes. If possible, wait for road conditions to improve before driving.

Follow all state, local and provincial driving and towing laws in the location you are driving in.

Not following your tow vehicle, trailer, and Husky instructions/manuals can result in a fatal accident.

### **Check Your Equipment**

Please refer to the MAINTENANCE section. Periodically check the condition of all your towing equipment and keep it in top condition.

### **Tire Inflation**

Unless specified otherwise by the towing vehicle or trailer manufacturer, tires should be inflated to their manufacturer's towing recommendations.

### **Towing Vehicle and Trailer Manufacturers Recommendations**

Review the owner's manual for your towing vehicle and trailer for specific recommendations, capacities and requirements.

### **Passengers in Trailers**

Trailers should not be occupied while being towed. Most states enforce this regulation.

### **Trailer Lights, Turn Signals, Electric Brakes**

Always hook up all of the trailer lights, electric brakes and break-away switch connection whenever trailer is being towed. Also periodically check functionality of all lights before towing and repair any problems as needed.

### **Remove Hitch When Not Towing**

Remove hitch from the towing vehicle when not towing a trailer to reduce chances of accidental damage and to reduce the chance of parts being stolen.

### **Maintenance**

Keep movable hitch assembly parts (jaw, pivot pin, etc...) lubricated when not in use.

Remove 5<sup>th</sup> wheel hitch from receiver and store in clean, dry place when not in use.

### **At The Beginning of Every Towing Day:**

If electric brakes are used ensure the emergency break away cable is attached to the tow vehicle.

Check to see that all electrical hook-ups are in working order and that the safety chains are securely connected.

Towing safely is the responsibility of the driver of the vehicle. Failure to tow safely can result in vehicle damage, bodily injury or death.

# Warranty Terms:

## 10 Year Limited Warranty:

This warranty applies solely to Husky 5<sup>th</sup> Wheel products manufactured by DTS Mfg. for Husky Towing Products.

Husky Towing Products and DTS Mfg. make no guarantees or warranties for products not manufactured by DTS Mfg. Such products are covered solely under any applicable warranty of the manufacturer. It is always recommended that the operating instructions and guarantee instructions provided by the manufacturer are followed.

DTS Mfg. warrants its products to be free from manufacturing and material defects to the original purchaser for the length of warranty stated above from the date of retail purchase. If any products are found to have a manufacturing or material defect, the product will be replaced or repaired at the option of Husky Towing Products and DTS Mfg. with proof of purchase by the original purchaser. The original purchaser shall pay all transportation and shipping costs associated with the return of the defective product and the defective product shall become the property of DTS Mfg.

The Warranty applies to DTS Mfg. products used for individual and recreational purposes. Commercial usage of the DTS Mfg. products limits the warranty to 90-days from date of purchase.

The Warranty applies only to DTS Mfg. products which are found to be defective in manufacturing or material. This warranty does not apply to normal wear and tear of the finished placed on DTS Mfg. products.

Husky Towing Products and DTS Mfg. are not responsible for any labor costs incurred for removal or replacement of the defective product.

Husky Towing Products and DTS Mfg. are not responsible for repair or replacement of any product under the limited warranty where the product was improperly installed, misapplied, altered, abused, neglected, overloaded, misused or damaged as a result of an accident, including any use of the product not in accordance with all product operating and safety instructions.

Without limiting the generality of the foregoing, Husky Towing Products and DTS Mfg. shall under no circumstances be liable for any incidental or consequential loss or damage whatsoever arising out of, or in any way relating to any such breach of warranty or claimed defect in, or non-performance of the products. Some states do not allow the exclusion or limitation of incidental or consequential damages, so the above exclusion or limitation may not apply to you.

This limited warranty gives you specific legal rights, and you may also have other rights that vary from state to state.