



Assembly, Installation, Operation and Maintenance Instructions Ford F150 4 Bolt Custom Installation Bracket Kit.

P/N: 32858

Dealer / Installer: Provide a copy of these Instructions to the end user of this product. These Instructions provide important operating and safety information for proper usage of this product. Demonstrate the proper use of the product with the end user. Have the end user demonstrate that they understand the proper use of the product.

End User: Read and follow all instructions included in this manual. Ask your Dealer / Installer for assistance if you do not understand the proper use of the product. Never remove any decals from the product.

Use with 10 bolt 30686 base rails ONLY. Base Rails are not included with this kit.

Caution: You must remove backing paper on rubber insulator pads to properly install. Once backing paper is removed and the rubber pads are installed; it is PERMANENT and cannot be removed. ONLY Install on the brackets and base rails. DO NOT install rubber insulator pads on the truck bed.

WARNING! Never exceed the towing capacity of the tow vehicle.

Center Bolt Kit 32059 (sold separately) must be used when towing with a 26K hitch, Goose Neck, or Maneuvering System.

Parts Diagram

Figure: 1

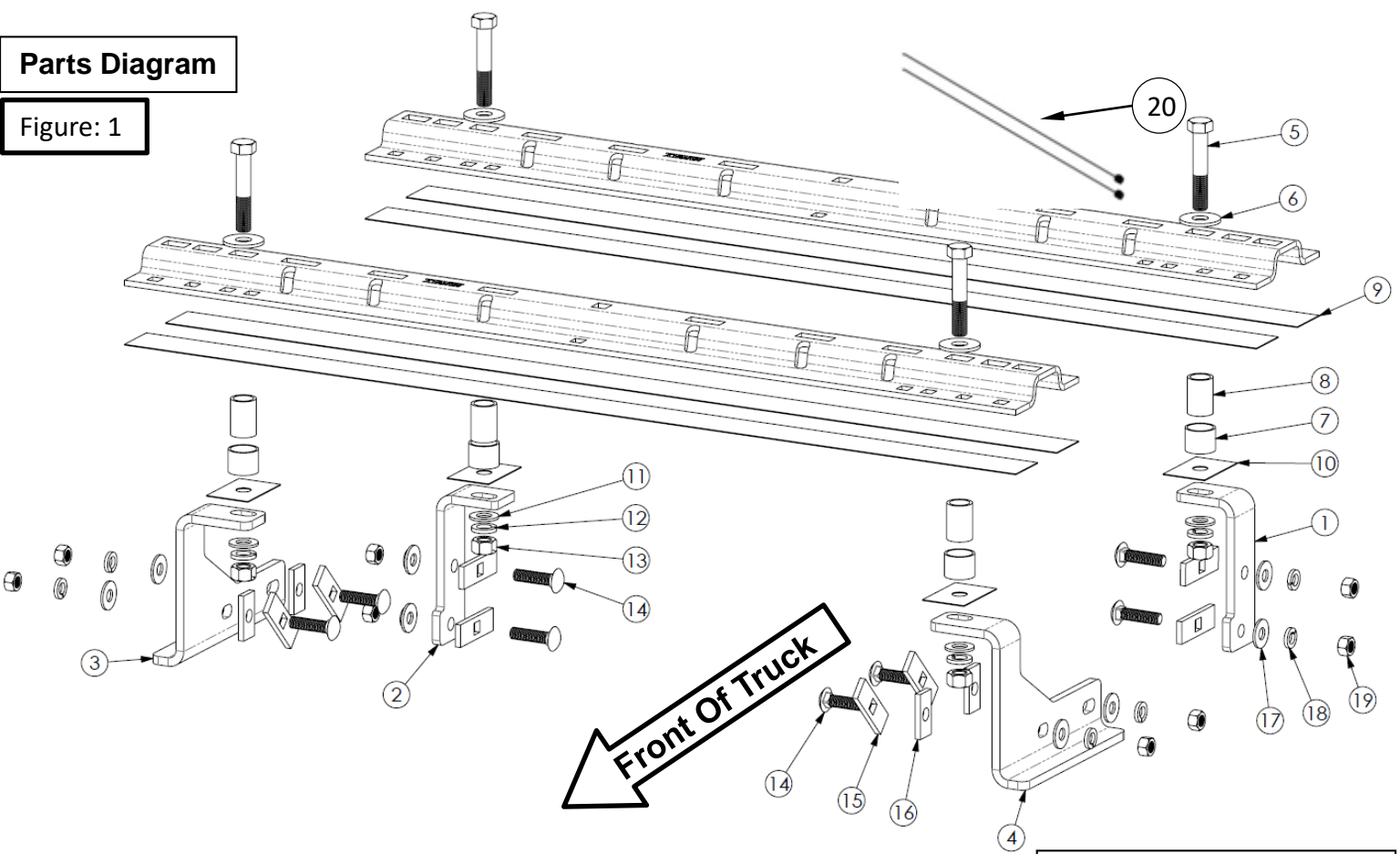

- TOOLS**
- 3/16" drill 1/2" Socket & Open End Wrench
 - 17/32" drill 5/8" Socket & Open End Wrench
 - 21/32" drill Torque Wrench
 - 1-5/16" drill "C" Clamps

Hardware Torque Values:
1/2" to 75 lb-ft
5/8" to 150 lb-ft

Do NOT use with base rail # 31323.

NO.	DESCRIPTION	QTY	NO.	DESCRIPTION	QTY
1	DRIVER SIDE REAR BRACKET	1	11	5/8" FLAT WASHER(1.25" O.D.)	4
2	PASSENGER SIDE REAR BRACKET	1	12	5/8" LOCK WASHER	4
3	PASSENGER SIDE FRONT BRACKET	1	13	5/8" -11 GR5 HEX NUT	4
4	DRIVER SIDE FRONT BRACKET	1	14	1/2"-13 X 1-3/4", GR5 CARRIAGE BOLT	8
5	5/8"-11 UNC X 3.5" HEX HEAD BOLT	4	15	1/2" CARRIAGE BOLT SPACER ,1"X3"	8
6	5/8" FLAT WASHER(1.75" O.D.)	4	16	1/4" SPACER PLATE	4
7	NYLON TUBE,1.3" OD	4	17	1/2" FLAT WASHER	8
8	SPACER ,TUBE	4	18	1/2" LOCK WASHER	8
9	BASE RAIL INSULATOR	4	19	1/2"-13 UNC HEX NUT	8
10	BRACKET INSULATOR	4	20	Pull Wire (1/2")	2

- The following instructions should be used to mount the fifth wheel. Care and attention to detail will ensure a quick quality installation. Check parts against parts list to become familiar with parts in kit. (See Fig. 1)
- Lower or removal of spare tire will give more room. Remove wheel well liner to allow access to truck frame.

WARNING:

If the truck is raised, be sure that the truck is properly blocked and restrained to prevent the truck from falling. Failure to do so may result in the truck suddenly falling, causing death or serious injury.

- Do **NOT** install mounting rails over plastic bed liners. Plastic bed liners must be cut out of the way. Base rails may be installed on spray in liner. **Note: Consult installer for recommended curing time.**
- Use only the supplied bolts, nuts and washers to install this kit. All bolts and nuts are Grade 5 unless specified otherwise.
- Specific instructions for most commonly used vehicles are included. Each frame bracket must be bolted to the vehicle frame with two bolts.

CAUTION:

These instructions are guidelines only. Actual installation is the responsibility of the installer and the owner. Always measure truck and trailer before installing hitch to be sure that there is clearance at the cab and at the bumper to allow for turns.

- Measurements are given from Rear Edge of truck bed to rear edge of the base rail closest to the Rear Edge of truck for most vehicle applications (See Fig. 2).
- Apply the base rail insulator strips(#9) on the bottom of each end of rail correctly to protect aluminum bed from corrosion as shown in fig.1 & 5A. Be sure to cover the entire bottom of the base rail with the base rail insulators. Center hitch between fender wells and make sure rails are square. Adjust position of rails until both diagonal measurements are the same. (See Fig. 2 & 3). Position the 5th wheel uprights between the bed rails so that the tabs in the base of each upright will fit into the slots in the ends of the bed rails. Secure the uprights in place with the rail hitch pins and hair pins supplied with the 5th wheel installation kit. Securely attach 5th wheel cross member to uprights. On most applications, the 5th wheel assembly should be positioned so that it is approximately centered over the truck axle and between the wheel wells on the bed floor.

CAUTION:

Check for obstructions before drilling. Failure to do so could result in damaged fuel or brake lines, structural members, etc. HUSKY TOWING PRODUCTS does its best to communicate tow vehicle manufacturer changes; however, it is ultimately the responsibility of the installer to prevent damage due to installation.

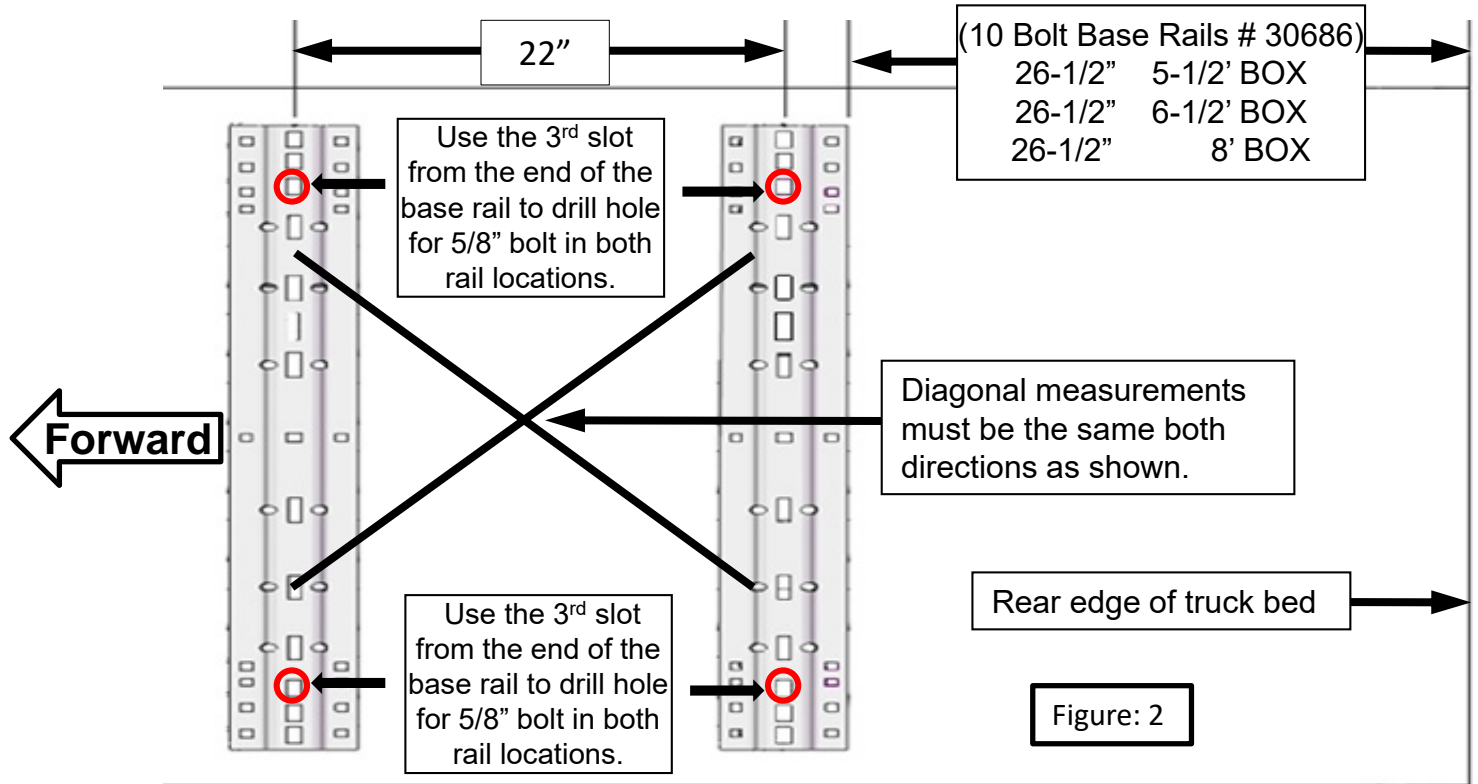

Figure: 2

8. Drill 4 holes identified in Fig. 2. (Hole location will vary for individual vehicle applications.) Drill all holes with 3/16" drill .Always use sharp drill bits. A 3/16" pilot hole will greatly speed drilling larger holes.

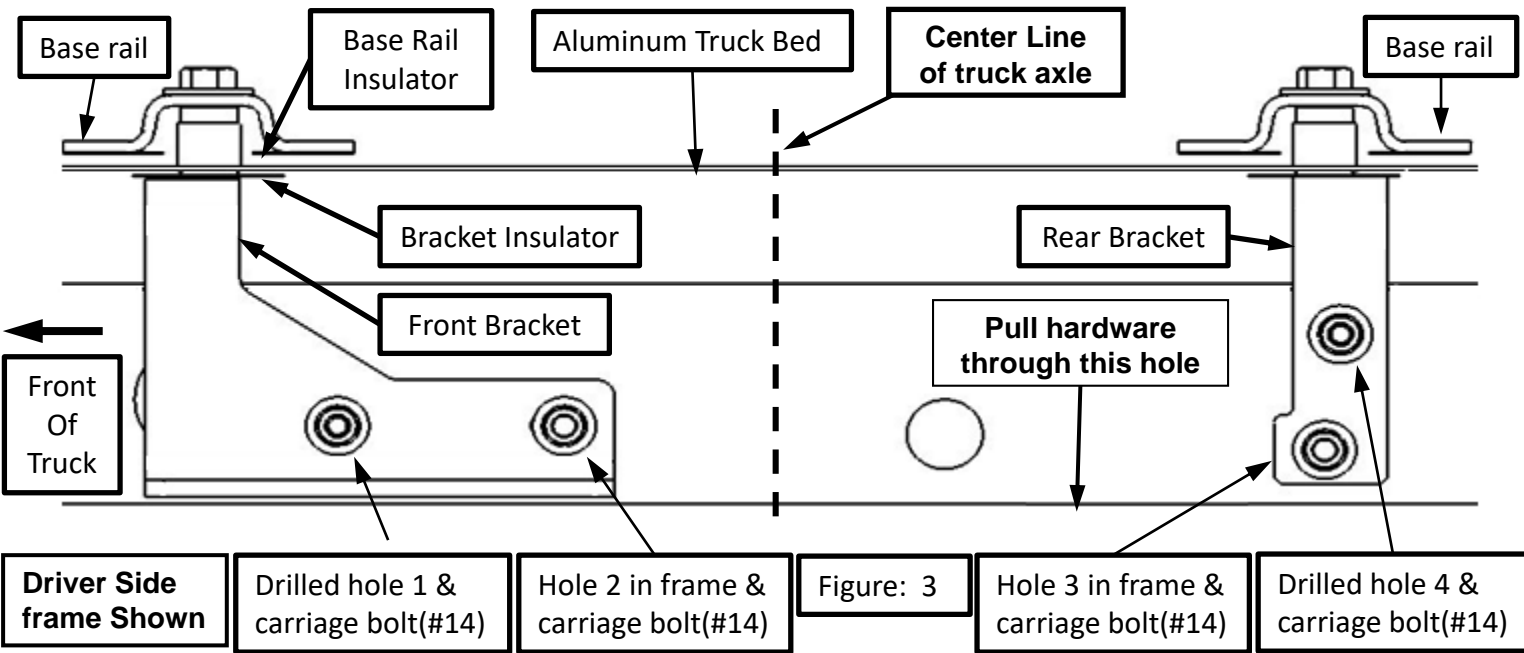

Figure: 3

9. Place rubber bracket insulator (#10) between bottom face of bed and top face of all brackets (#1, #2, #3 & #4) as shown in fig. 5A & 5B. Do NOT remove the backing paper YET. You may need to adjust the position later in Step 15.

10. Install frame brackets (#1, #2, #3 & #4) using appropriate hardware and tighten hand tight.

- Insert the head of the pull wire (#20) through the 1-1/2" diameter hole on the side of the truck frame and out through the hole "2" & "3" (shown in fig.3) on the side of the frame.
- Slide the spacer (#15) over the head of the bolt leader and attach the 1/2" x 1-3/4" carriage bolt (#14).
- Push the hardware up into the frame through the large access hole on the side of frame.

- With the other end of the pull wire (#20), thread it through the spacer plate (#16) then through the back side of the frame brackets. gently pull on the end of the pull wire (#20) so that the hardware moves through the frame and into position in the frame bracket. (see fig.4A & 4B). Bolt in “hole 3” will directly pass through bracket, there is NO spacer plate (#16) between frame and bracket (see fig.4B).
- Install the 1/2” flat washer (#17) , 1/2” lock washer (#18) and 1/2” hex nut (#19) hand tighten.

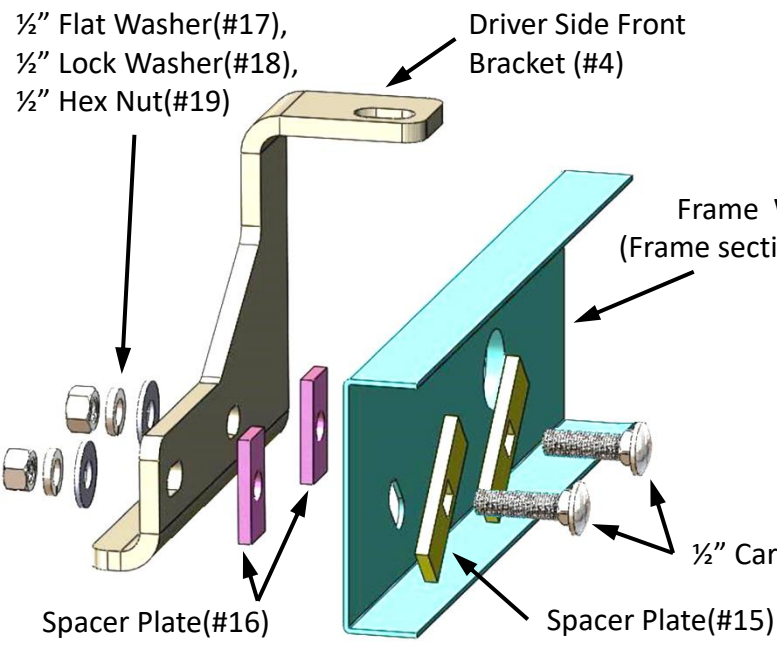

Driver Side Front Bracket Shown

Figure: 4A

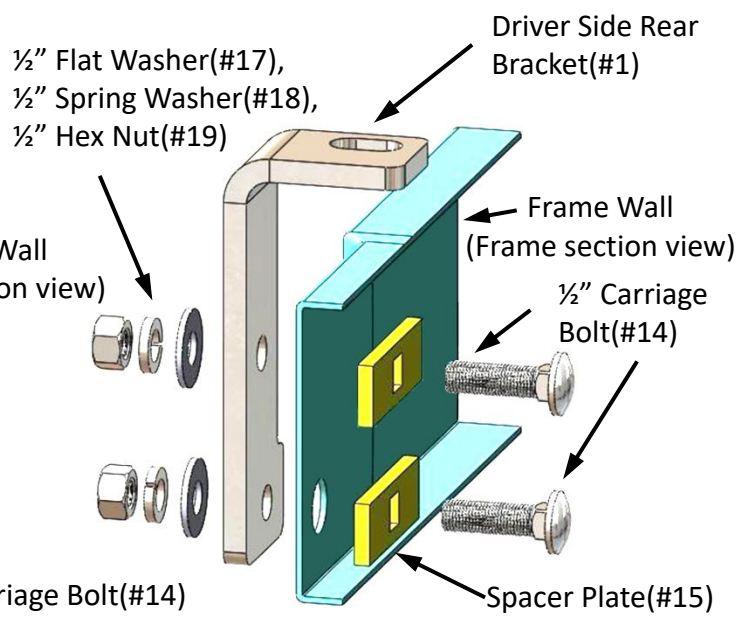

Driver Side Rear Bracket Shown

Figure: 4B

WARNING:
DO NOT lubricate threads. It may cause bolt failure.

11. Drill “hole 1” and “hole 4” using 17/32” drill as shown location in fig.3. Do NOT drill through both walls of frame. Drill only through wall of frame to which bracket is mounted.
12. Using pull wire, pull 1/2” carriage bolt (#14) through hole on the side of frame and out to Hole 1 & 4 .Bolt in “Hole 1” will pass through spacer plate which is placed between outer face of frame and inner side of bracket (fig.4A). Pull it so that the hardware moves through the frame and into position in the frame bracket (see fig.4A). Bolt in “hole 4” will directly pass through bracket, there is no spacer plate between frame & bracket (see fig.4B). Install the 1/2” flat washer (#17) , 1/2” lock washer (#18) and 1/2” hex nut (#19) hand tighten.

CAUTION:
Check for obstructions before drilling. Failure to do so could result in damaged fuel or brake lines, structural members, etc. HUSKY TOWING PRODUCTS does its best to communicate tow vehicle manufacturer changes; however, it is ultimately the responsibility of the installer to prevent damage due to installation.

CAUTION:
It is important that 17/32" drill be used for holes in chassis frame as rib neck bolts may break if too small a hole is used and neck may not grip if too large a hole is used.

13. Check that the 3/16" drilled holes align with slots of all brackets (#1,#2,#3,#4) .and enlarge them with a 1-5/16" drill. Place spacer tube (#8) & nylon tube (# 7) above bracket through bed on drilled location as shown in figure.5A . Nylon tube (#7) must be properly placed to prevent contacts between spacer tube(#7) and truck bed. Place base rails over drilled position as shown in fig.2 & 5A
14. Temporarily insert 5/8"x 3.5" hex head bolt (#5) through 5/8 flat washer (#6), rail, spacer tube (#8), nylon tube(#7) and brackets. Use a marker to mark the location of the 5/8" hardware on the brackets. This will help align the center of the rubber insulator (#10) in the next step.
15. Remove the 5/8"x 3.5" hex head bolt (#5) through 5/8 flat washer (#6), rail ,spacer tube (#8) ,nylon tube (#7) and brackets. Apply the rubber insulator (#10) to the bracket. Align the hole in the rubber insulator to the marks on the brackets. Fold the extra material of the rubber insulator around the front and rear edges of the brackets as best as possible. Secure it with 5/8" flat washer (#11) 5/8" lock washer (#12) and 5/8" hex nut (#13).

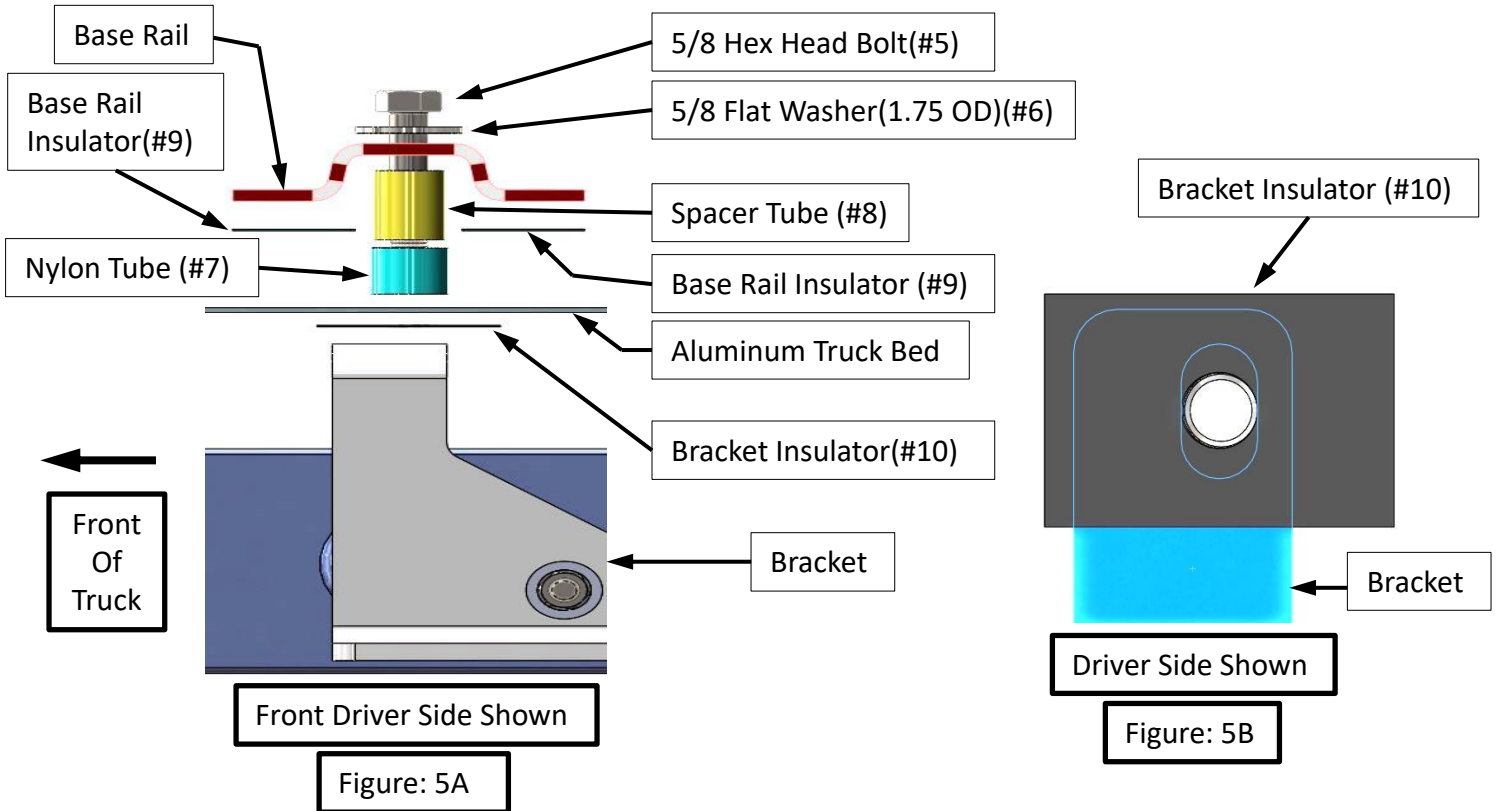

16. Reinstall the 5/8" x 3.5" hex head bolt (#5) through 5/8 flat washer (#6), rail, spacer tube (#8), nylon tube (#7) and brackets. Secure them with 5/8" flat washer (#11) 5/8", lock washer (#12) and 5/8" hex nut (#13).
17. To correct the location of the second mounting rail, place one leg's tab of unassembled fifth wheel into already installed base rail and position the other rail by inserting other tab in to rail . both rail must be in center of truck bed width .This will place base rail in correct positioned make sure that 5th wheel has secure fit.

Note: If more than one hitch product will be used with the rails then both should be used at the same time to align the second rail. This will ensure that one product does not compromise the fit of the other.

18. Repeat Step 14 to secure second rail with bed and bracket.
19. Torque all 1/2" hardware to 75 ft-lbs. and 5/8" hardware to 150 ft-lbs. First torque the mounting rails to the frame brackets and then torque the frame brackets to the truck frame.
20. Reinstall spare tire and wheel well liner if removed.

Warranty Terms:

5 Year Limited Warranty:

This warranty applies solely to Husky 5th Wheel Installation Kit manufactured by LKQ Specialty Products Group for Husky Towing Products.

Husky Towing Products and LKQ Specialty Products Group make no guarantees or warranties for products not manufactured by LKQ Specialty Products Group. Such products are covered solely under any applicable warranty of the manufacturer. It is always recommended that the operating instructions and guarantee instructions provided by the manufacturer are followed.

LKQ Specialty Products Group warrants its products to be free from manufacturing and material defects to the original purchaser for the length of warranty stated above from the date of retail purchase. If any products are found to have a manufacturing or material defect, the product will be replaced or repaired at the option of Husky Towing Products and LKQ Specialty Products Group with proof of purchase by the original purchaser. The original purchaser shall pay all transportation and shipping costs associated with the return of the defective product and the defective product shall become the property of LKQ Specialty Products Group.

The Warranty applies to LKQ Specialty Products Group products used for individual and recreational purposes. Commercial usage of the LKQ Specialty Products Group products limits the warranty to 90-days from date of purchase.

The Warranty applies only to LKQ Specialty Products Group products which are found to be defective in manufacturing or material. This warranty does not apply to normal wear and tear of the finished placed on LKQ Specialty Products Group products.

Husky Towing Products and LKQ Specialty Products Group are not responsible for any labor costs incurred for removal or replacement of the defective product.

Husky Towing Products and LKQ Specialty Products Group are not responsible for repair or replacement of any product under the limited warranty where the product was improperly installed, misapplied, altered, abused, neglected, overloaded, misused or damaged as a result of an accident, including any use of the product not in accordance with all product operating and safety instructions.

Without limiting the generality of the foregoing, Husky Towing Products and LKQ Specialty Products Group shall under no circumstances be liable for any incidental or consequential loss or damage whatsoever arising out of, or in any way relating to any such breach of warranty or claimed defect in, or non-performance of the products. Some states do not allow the exclusion or limitation of incidental or consequential damages, so the above exclusion or limitation may not apply to you.

This limited warranty gives you specific legal rights, and you may also have other rights that vary from state to state.