



Assembly, Installation, Operation and Maintenance Instructions

Base Rail Bracket Kit

P/N: 32831

Dealer / Installer: Provide a copy of these Instructions to the end user of this product. These Instructions provide important operating and safety information for proper usage of this product. Demonstrate the proper use of the product with the end user. Have the end user demonstrate that they understand the proper use of the product.

End User: Read and follow all instructions included in this manual. Ask your Dealer / Installer for assistance if you do not understand the proper use of the product. Never remove any decals from the product.

Use with 4 bolt 31323 or 10 bolt 30686 base rails. Base Rails are not included with this kit.

WARNING! Never exceed the towing capacity of the tow vehicle.

Center Bolt Kit 32059 (sold separately) must be used when towing with a 26K hitch, Goose Neck, or Maneuvering System.

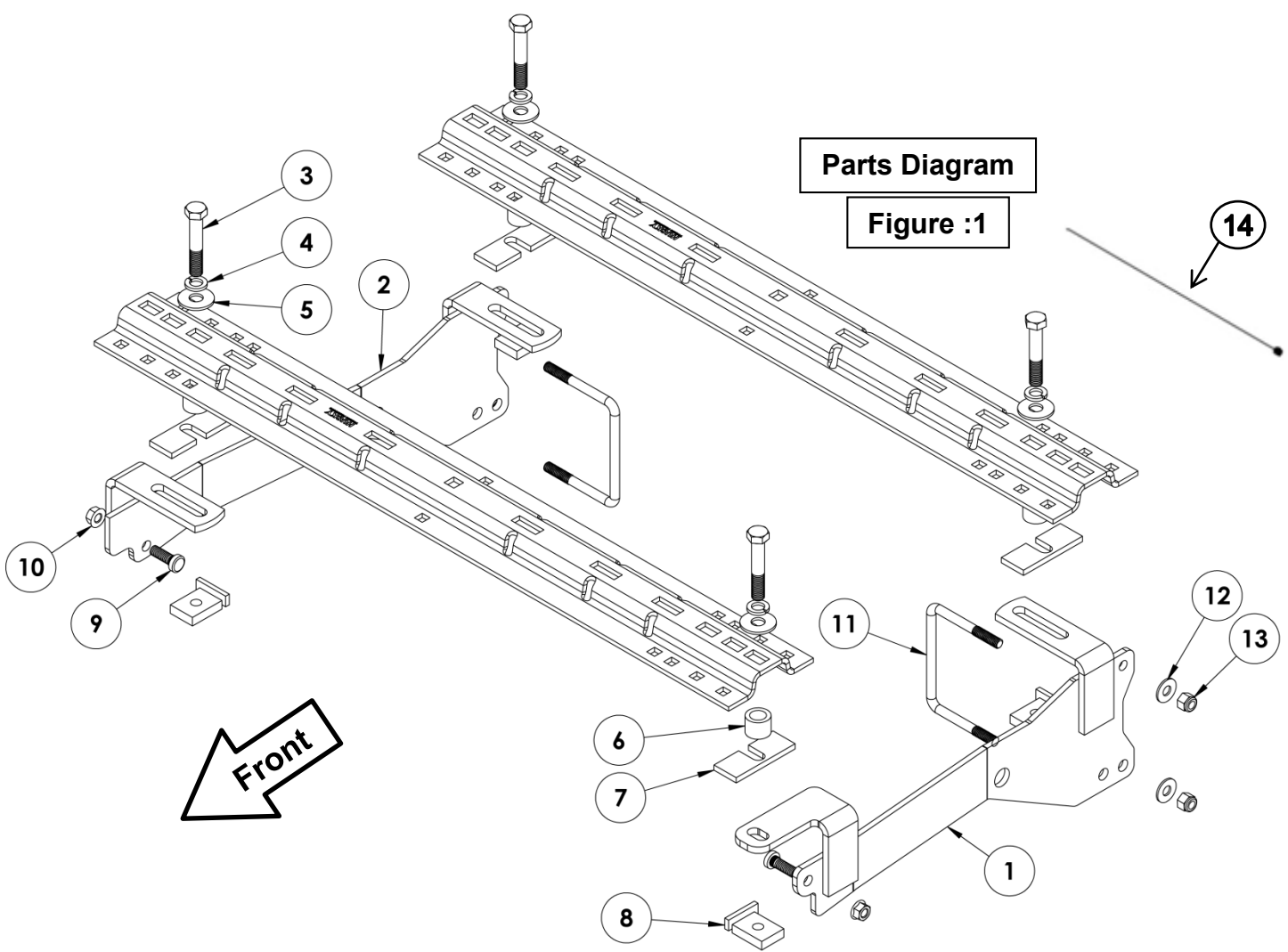

TOOLS

3/16" & 11/16" drill bits.

5/8" Transfer Center Punch.

1-1/4" hole saw.

18mm, 3/4" & 15/16" Socket & Open End Wrench.

Torque Wrench capable of 150 lb-ft.

1. The following instructions should be used to mount the fifth wheel. Care and attention to detail will ensure a quick quality installation. Check parts against parts list to become familiar with parts in kit.
2. Raise rear of truck high enough to allow jack stands to be placed under rear spring hanger bracket of truck. This will provide maximum room to install the fifth wheel brackets.

WARNING:

If the truck is raised, be sure that the truck is properly blocked and restrained to prevent the truck from falling. Failure to do so may result in the truck suddenly falling, causing death or serious injury.

3. **Do NOT install mounting rails over plastic bed liners.** Plastic bed liners must be cut out of the way. Base rails may be installed on dry/cured spray in liner. **Note: Consult installer for recommended curing time.**
4. Use only the supplied bolts, nuts, and washers to install this kit. All nuts and bolts are Grade 5 unless specified otherwise.

CAUTION:

These instructions are guidelines only. Actual installation is the responsibility of the installer and the owner. Always measure truck and trailer before installing hitch to be sure that there is clearance at the cab and at the bumper to allow for turns.

5. The wheel well liners will need to be removed to access the frame for bracket installation.
6. Measurements are given from rear edge of truck bed to rear edge of the base rail closest to the rear edge of truck for most vehicle applications.
7. Place the two bed rails across the truck bed between the wheel wells. Position the 5th wheel uprights between the bed rails so that the tabs in the base of each upright will fit into the slots in the ends of the bed rails. Secure the uprights in place with the rail hitch pins and hair pins supplied with the 5th wheel installation kit. Securely attach 5th wheel cross member to uprights.
8. On most applications, the 5th wheel assembly should be positioned so that it is approximately centered over the truck axle and between the wheel wells on the bed floor. See Figure 3 on page 3.

CAUTION:

Check for obstructions before drilling. Failure to do so could result in damaged fuel or brake lines, structural members, etc. HUSKY TOWING PRODUCTS does its best to communicate tow vehicle manufacturer changes; however, it is ultimately the responsibility of the installer to prevent damage due to installation.

PARTS LIST

ITEM NO.	DESCRIPTION	QTY.
1	Driver Side Mounting Bracket	1
2	Passenger Side Mounting Bracket	1
3	5/8" -11 X 3.50" Grade 5 Hex Head Bolt	4
4	5/8" Lock Washer	4
5	5/8" Flat Washer	4
6	1" Spacer Tube	4
7	1/4" Thick Spacer Plate	4
8	5/8" -11 Tapped Plate	4
9	1/2" -13 X 1-1/2" Wheel Bolt	2
10	1/2" -13 Serrated Lock Nut	2
11	1/2" U-Bolt	2
12	1/2" Flat Washer	4
13	1/2" -13 Nylock Nut	4
14	Pull Wire for 1/2"-13 Threaded Bolt	1

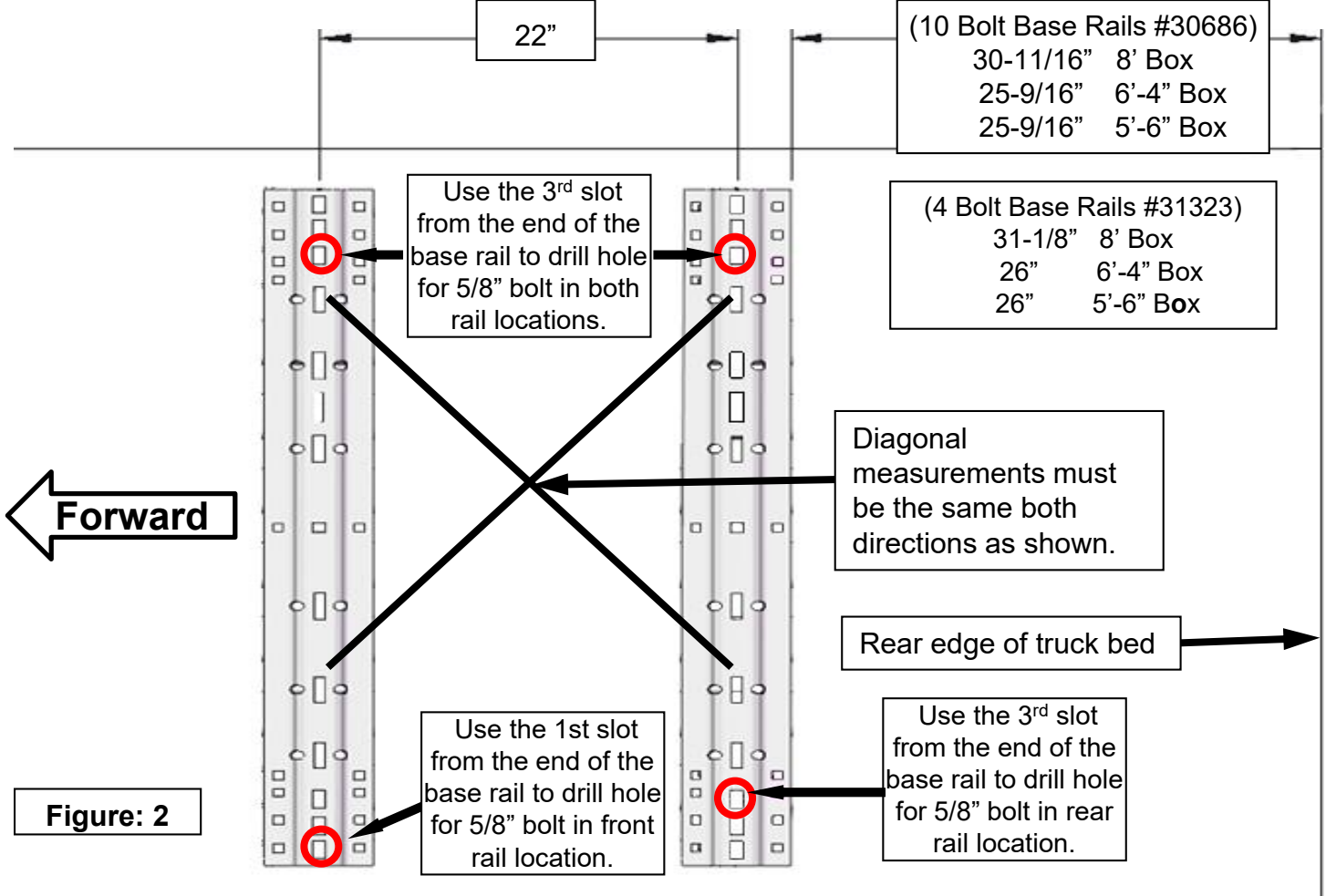

Both the short bed & long bed hitch center lines should be about 3/4" forward of the rear axle center line.

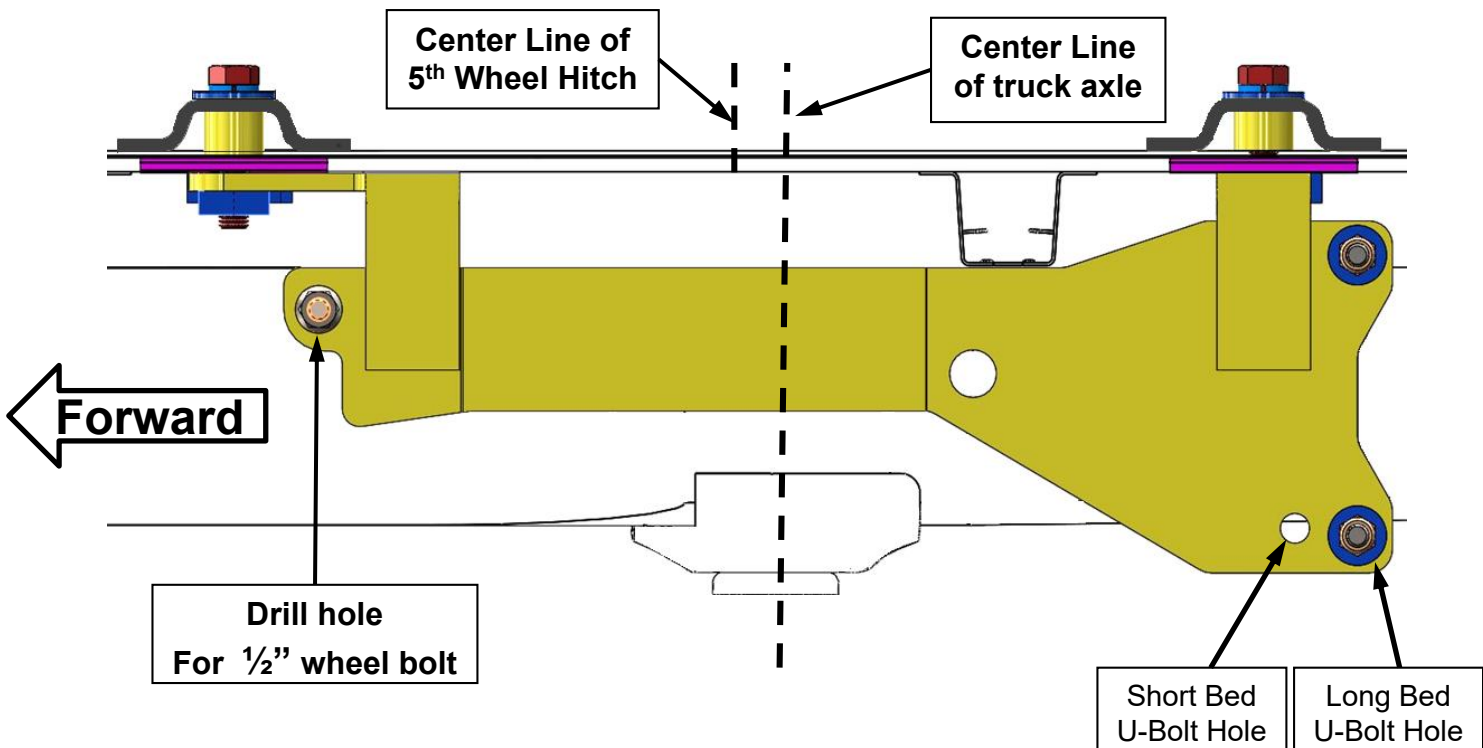

Figure:3

DRIVERS SIDE OF FRAME IS SHOWN

NOTE: To keep the trailer from hitting the cab on tight turns there must be at least 52" between the center of the hitch and the cab. On long bed pickups the hitch center line may be up to 3" ahead of the axle. On short bed pickups this position is not possible. A 5th wheel hitch that can move the trailer rearward away from the truck cab should be used with a truck bed length less than 8 ft, consult the Husky Towing Products catalog to select the product that best matches your needs.
DO NOT USE with a truck bed length less than 6 ft.

- When hitch is correctly positioned in the bed and the bed rails are parallel. See Figure 2 for measurements. Mark four attachment points on the truck bed using the 5/8" rectangular slots at the ends of each bed rail as a guide. The use of a 5/8" transfer center punch will ensure that the marks are correctly marked on the bed floor. Check below the bed before drilling holes to see that all wiring, brake lines or other obstructions are moved out of the way and will not be contacted by the drill bit. Move the hitch assembly out of the way and drill four 5/8" diameter attachment holes down through the bed at the previously marked points.
- Reposition the bed rails in the bed so that the square 5/8" hole in the end of each rail is lined up over the drilled holes. Place a 1" spacer tube (#6) under ends of each bed rail, in line with the drilled holes as shown in fig.4.

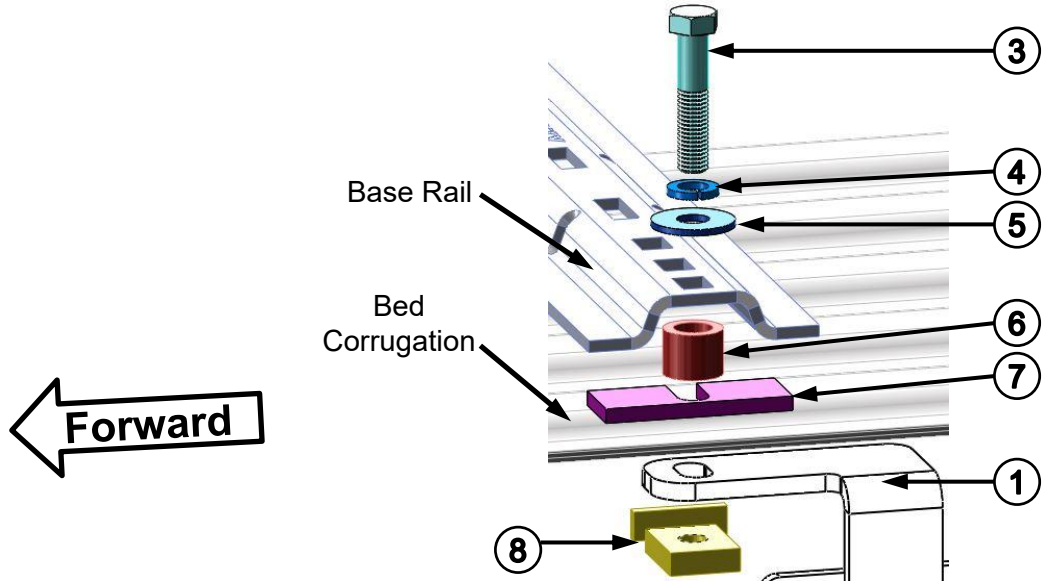

Figure:4 **Driver Side Front Shown**

- If the bed corrugation above the frame bracket is UP, leaving a space above the frame bracket, place a spacer plate (#7) in this location as shown in fig. 5A. If the corrugation is DOWN, at this location, place a spacer plate (#7) in the bed, under the base rail as shown in fig. 5B

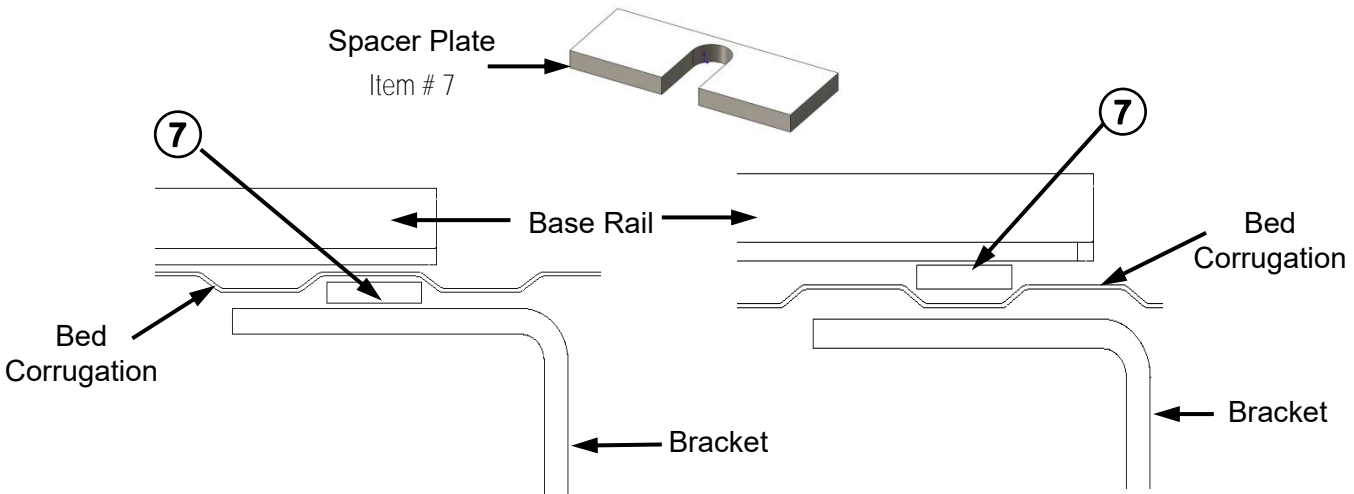

Figure:5 A **Spacer Plate under the bed**

Figure:5 B **Spacer Plate over the bed**

11. Position the left frame brackets (#1) up against the outer surface of the truck frame with the mounting tabs positioned over the frame and under the bed in line with previously drilled holes in bed.

Be careful to place drivers side bracket front tabs over wiring loom and underneath of truck bed. (Do not pinch wires), see Fig. 6A and on passenger side, place front tab of bracket over heat shield and underneath the truck bed, see Fig. 6B.

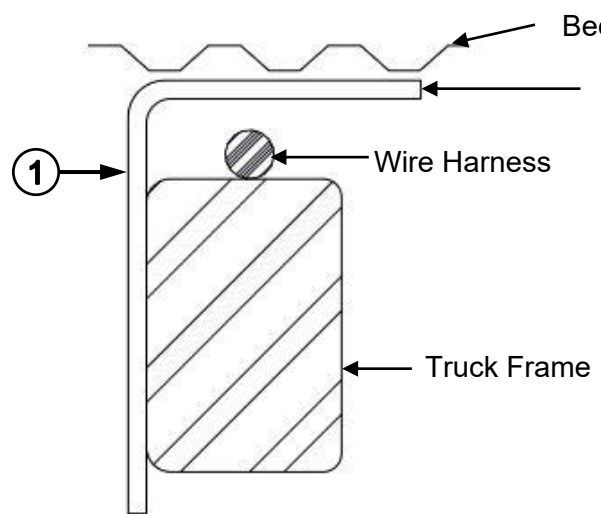

Figure:6 A | **Driver Side Front**

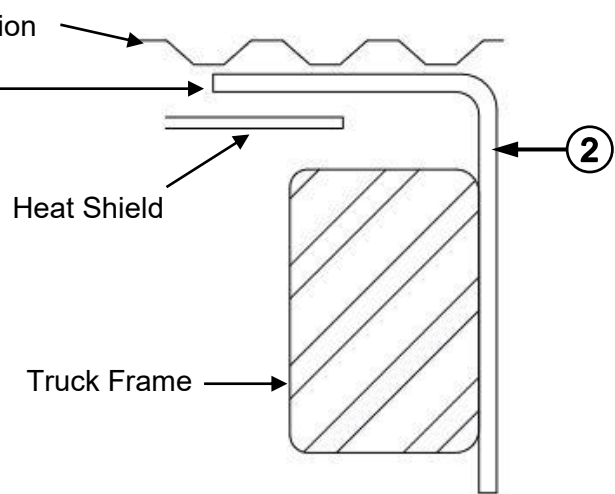

Figure:6 B | **Passenger Side Front**

12. Place U-Bolt (#11) around the truck frame at about 12" behind rear axle shown in Fig.1(Parts Diagram). For U-Bolt holes to be used for long bed or short bed, see Fig.3. on page 3. Be careful to get drivers side

U-Bolt under the wiring loom and up against the truck frame. (Do not pinch wires under the U-Bolt),

see Fig. 6C

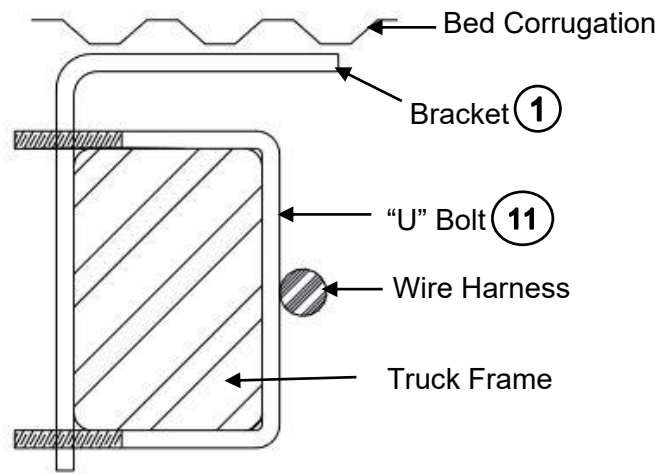

Figure:6 C | **Driver Side Rear**

13. Move the frame bracket so that it rests tightly against the flat side of the truck frame and underneath of truck bed. Drop the 5/8" hex bolts with lock washer and flat washer down through bed rails and angle bracket. Thread bolts into tapped plates (#8) placed under frame bracket tabs. Loosely bolt frame brackets in place. Be sure they are tight against the side of truck frame shown in Illustration below.

- Push U-Bolt through bracket and use flat washer and hex nylock nut to attach bracket to frame. See Illustration above.

14. Before drilling hole in front of bracket, check inside the frame to be sure that there are no wires, brake lines or other obstructions in the frame which may be contacted by the drill. Each of the frame brackets must be attached to the side frame of the truck with a special 1/2" wheel bolt at the forward hole and a U-Bolt at the rear holes. Be sure the bracket's 1" Diameter hole is over large slot in truck frame.

- At the front attachment point, drill a 17/32" hole through the side of the truck frame using the hole in each frame bracket as a guide as shown location in fig.3

CAUTION:

Holes **MUST** be drilled $17/32$ " diameter, so that the special wheel bolts will seat properly. If holes are too small, the bolt may break. If hole is too large, the bolt will not grip properly.

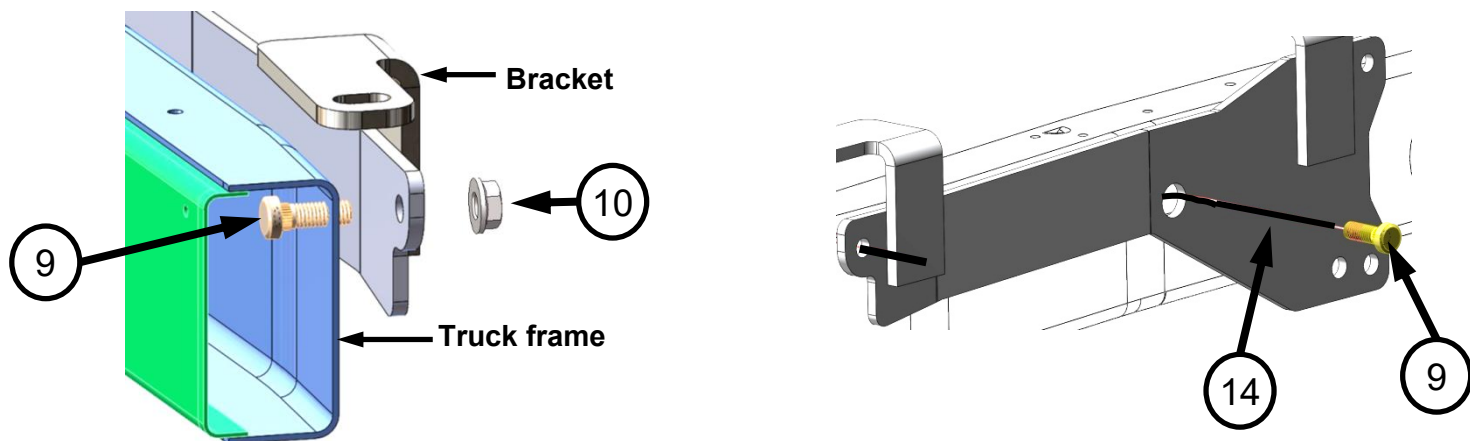

Figure:7 | **Front Driver Side Shown**

15. Insert the coiled end of the pull wire (#14) through $17/32$ " hole (see fig.7), angle the wire to guide the coiled end along the inside of the truck frame rearward. Continue feeding pull wire and look through the 1" dia. bracket hole for the coiled end of the pull wire. Use a pair of needle nose pliers to guide the coiled end of the pull wire out through the 1" dia. hole, ensure the other end of the pull wire remains protruding through the $17/32$ " hole. Thread the end of the wheel bolt into the coiled end of the pull wire completely. Carefully pull the other end of the pull wire and guide the wheel bolt into the 1" dia. bracket hole. Continue pulling wire so the threaded end of the wheel bolt can be pulled through the $17/32$ " dia. hole from the inside. Hold onto the wheel bolt with one hand and carefully remove the pull wire from the threads, then install the nylock nut onto the wheel bolt. Use of an air wrench will make seating the serrations of the wheel bolt into the hole much easier. Otherwise you can use a standard $1/2$ " nut to start pulling the wheel bolt through the hole and then replace it with the nylock nut.
16. Tighten all $1/2$ " attachment bolts to 75 ft.-lbs. and the $5/8$ " bolts to 150 ft.-lbs. torque. Failure to tighten bolts as described may result in fastener loss or failure.
17. Check each rail hitch pin for freedom of movement in the bed rail connection. Adjust uprights, if necessary, by placing shim 31582 or 30243 between the upright and the cross member to obtain free pin movement. See Fig. 8. Shims 31582 & 30243 sold separately.

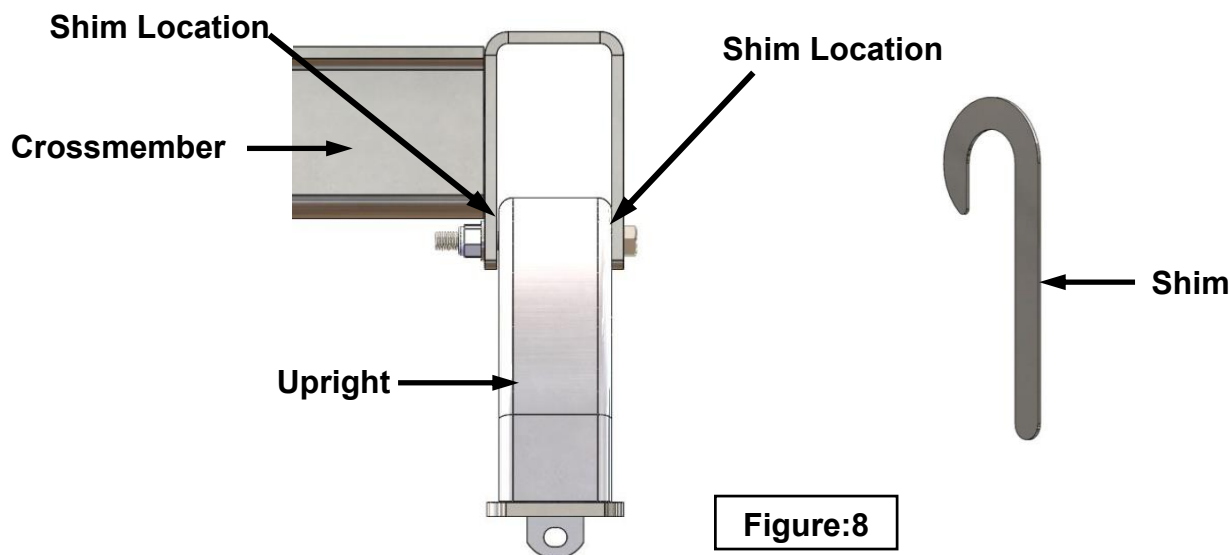

Figure:8

Warranty Terms:

5 Year Limited Warranty:

This warranty applies solely to Husky 5th Wheel Installation Kit manufactured by LKQ Specialty Products Group for Husky Towing Products.

Husky Towing Products and LKQ Specialty Products Group make no guarantees or warranties for products not manufactured by LKQ Specialty Products Group. Such products are covered solely under any applicable warranty of the manufacturer. It is always recommended that the operating instructions and guarantee instructions provided by the manufacturer are followed.

LKQ Specialty Products Group warrants its products to be free from manufacturing and material defects to the original purchaser for the length of warranty stated above from the date of retail purchase. If any products are found to have a manufacturing or material defect, the product will be replaced or repaired at the option of Husky Towing Products and LKQ Specialty Products Group with proof of purchase by the original purchaser. The original purchaser shall pay all transportation and shipping costs associated with the return of the defective product and the defective product shall become the property of LKQ Specialty Products Group.

The Warranty applies to LKQ Specialty Products Group products used for individual and recreational purposes. Commercial usage of the LKQ Specialty Products Group products limits the warranty to 90-days from date of purchase.

The Warranty applies only to LKQ Specialty Products Group products which are found to be defective in manufacturing or material. This warranty does not apply to normal wear and tear of the finished product placed on LKQ Specialty Products Group products.

Husky Towing Products and LKQ Specialty Products Group are not responsible for any labor costs incurred for removal or replacement of the defective product.

Husky Towing Products and LKQ Specialty Products Group are not responsible for repair or replacement of any product under the limited warranty where the product was improperly installed, misapplied, altered, abused, neglected, overloaded, misused or damaged as a result of an accident, including any use of the product not in accordance with all product operating and safety instructions.

Without limiting the generality of the foregoing, Husky Towing Products and LKQ Specialty Products Group shall under no circumstances be liable for any incidental or consequential loss or damage whatsoever arising out of, or in any way relating to any such breach of warranty or claimed defect in, or non-performance of the products. Some states do not allow the exclusion or limitation of incidental or consequential damages, so the above exclusion or limitation may not apply to you.

This limited warranty gives you specific legal rights, and you may also have other rights that vary from state to state.

Rely on [premium trailer hitches & towing by Husky Towing if you're looking for quality and efficiency.](#)