



# KIT, SERVICE, 16K HUSKY 10 PS PIVOT ASSEMBLY

Part # 31796

**Dealer / Installer:** Provide a copy of these Instructions to the end user of this product. These Instructions provide important operating and safety information for proper usage of this product. Demonstrate the proper use of the product with the end user. Have the end user demonstrate that they understand the proper use of the product.

**End User:** Read and follow all instructions included in this manual. Ask your Dealer / Installer for assistance if you do not understand the proper use of the product. Never remove any decals from the product.

## DISASSEMBLY

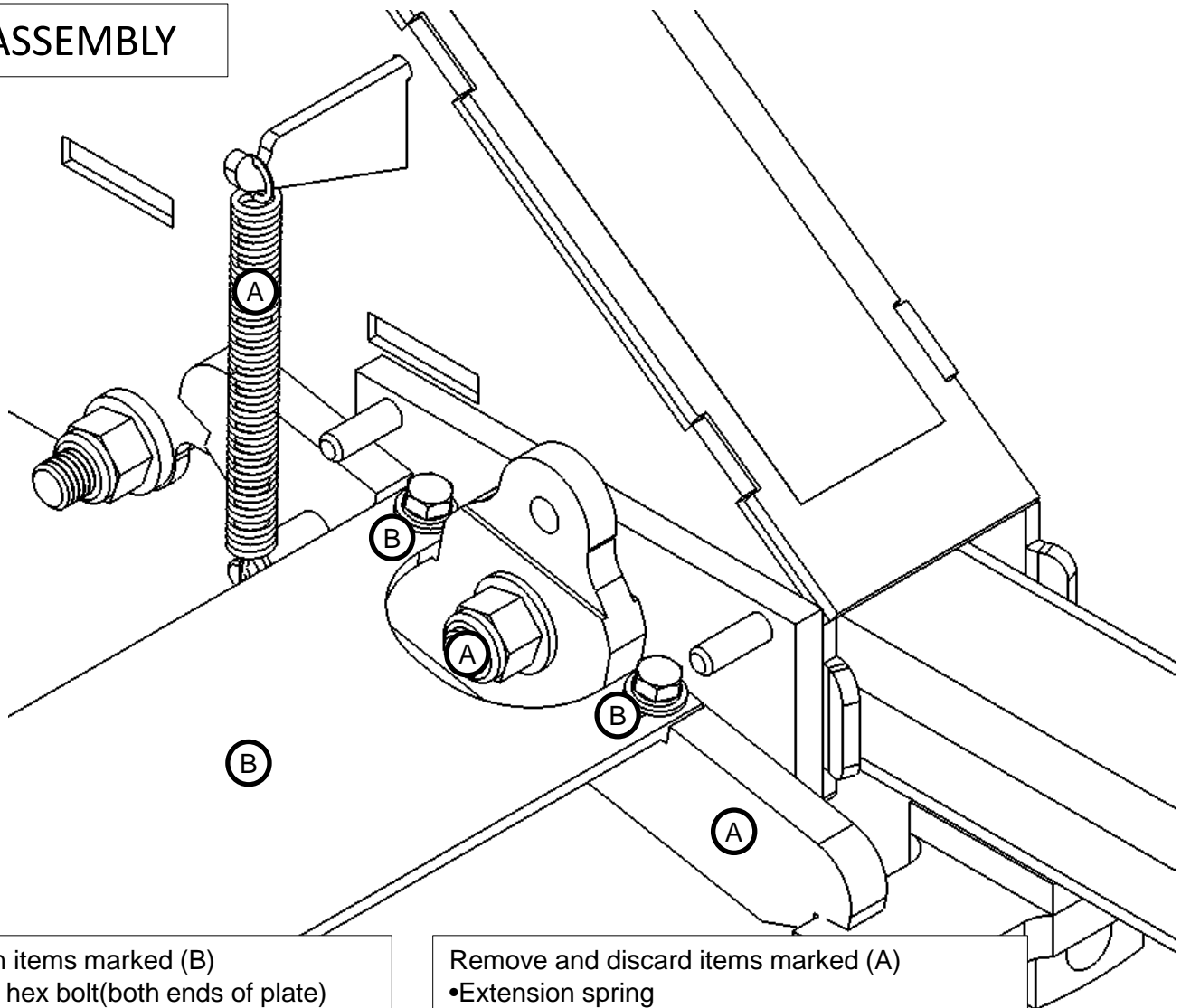

### Retain items marked (B)

- 1/4-20 hex bolt(both ends of plate)
- 1/4" Lock washer(both ends of plate)
- 1/4" Flat washer(both ends of plate)
- Pivot plate
- Flipper

### Remove and discard items marked (A)

- Extension spring
- Spring plate
- Clevis/cotter pins
- Flipper
- 1/2-13 lock nut and flat washer

# KIT CONTENTS

Parts listing	
Item no.	Description
1	Flipper assembly
2	½-13 Lock nut
3	½" Flat washer
4	Extension spring

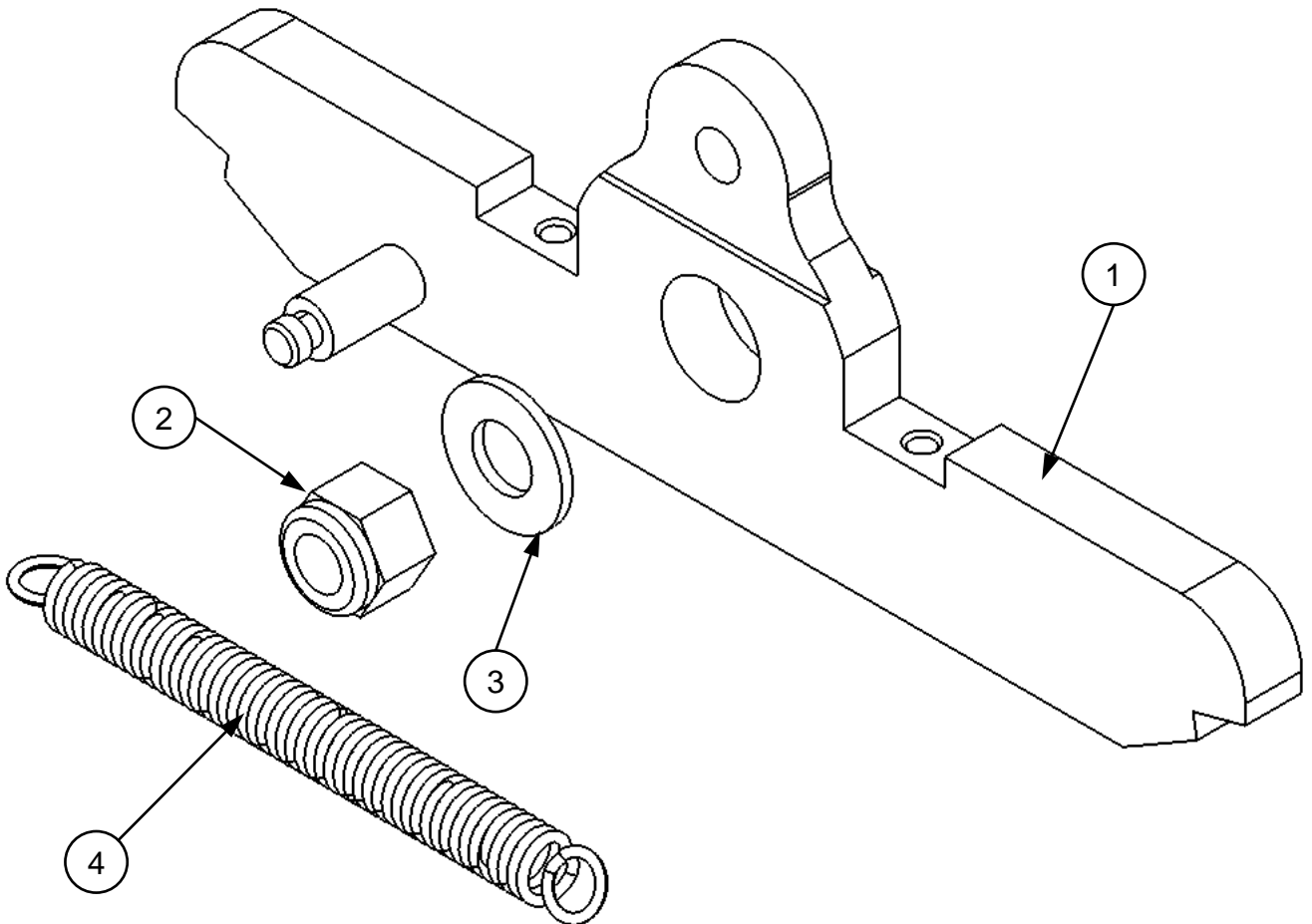

Tools required	
Needle nose pliers	¾" Socket and ratchet
100 ft. Lbs. Min. Torque wrench	Thick grease

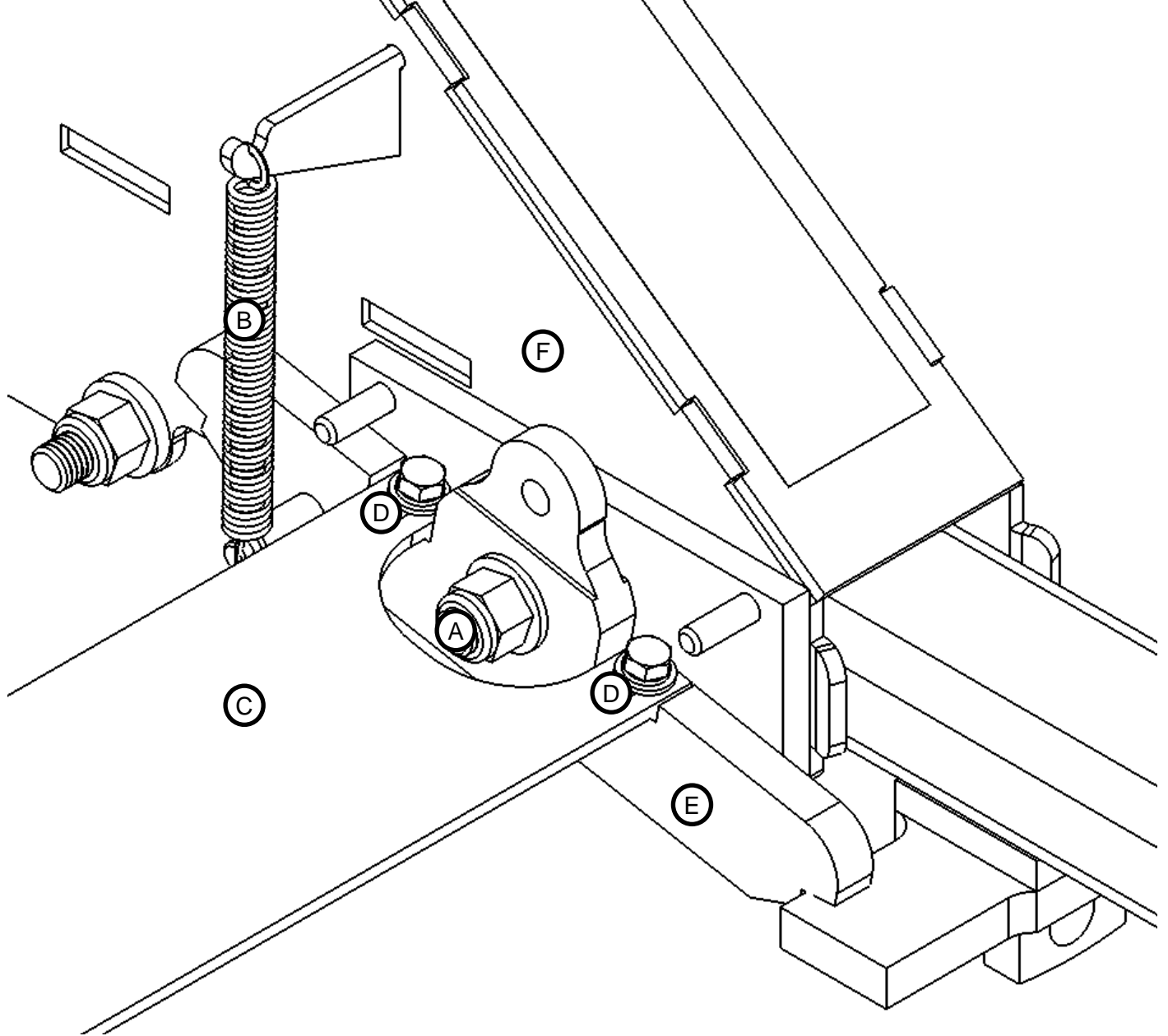

## ASSEMBLY AND ADJUSTMENT INSTRUCTIONS:

1. Apply grease to the pivot shaft (A).
2. Slide flipper assembly on to pivot shaft (A).
3. Install ½" flat washer and ½-13 lock nut on to pivot shaft (A) and torque to 75 lbs. ft.
4. Install extension spring (B) as shown.
5. Install pivot plate (C) onto flats (D) of flipper (E) and install ¼-20 hex bolts, lock/flat washers loosely.
6. Center the pivot plate (C) so that it is centered left to right.
7. Align flat surface of driver side flipper (E) so it is parallel to inside of housing surface (F) and tighten ¼-20 hex bolts. Repeat this for the driver side flipper.
8. By hand, grab a hold of pivot plate (C) and rotate to ensure that it will move freely.
9. Put the handle into the maneuver position and slide the hitch assembly into the maneuver position and confirm that the stop edge on the pivot stops touch the stop tab.
10. If all moves without binding and the pivot stop surface makes full contact with the stop tab in both positions then you are ready to complete the assembly by attaching the 5th wheel head and related components.