



Assembly, Installation, Operation and Maintenance Instructions

Universal Bracket Kit Part # 31563

Use with Base Rail Kit 31323 (4 Bolt) or 30686 (10 Bolt)

Dealer / Installer:	Provide a copy of these Instructions to the end user of this product. These Instructions provide important operating and safety information for proper usage of this product. Demonstrate the proper use of the product with the end user. Have the end user demonstrate that they understand the proper use of the product.
End User:	Read and follow all instructions included in this manual. Ask your Dealer / Installer for assistance if you do not understand the proper use of the product. Never remove any decals from the product.

WARNING! Never exceed the towing capacity of the tow vehicle.

Center Bolt Kit 32059 (sold separately) must be used when towing with a 26K hitch, Goose Neck, or Maneuvering System.

CAUTION: Do not install base rails over plastic bed liners. Plastic bed liners must be cut out of the way. Rails may be installed on spray in liners. Consult spray liner installer for recommended curing time.

Tools Required	
3/4" Wrench & Socket	3/16" Drill Bit
15/16" Wrench & Socket	Drill
1-1/4" Hole Saw	Ratchet
5/8" Drill Bit	Torque Wrench (150 ft-lbs)
17/32" Drill Bit	Safety Glasses

ITEM NO.	Description	QTY.
1	3/16" SPACER PLATE	1
2	BRACKET, "L" LONG	2
3	RIGHT ANGLE BRACKET	1
4	LEFT ANGLE BRACKET	1
5	SPACER, 1.250" OD X .219" WALL X 1.000" TALL	4
6	SPACER PLATE	4
7	5/8 FLANGE NUT PLATE	4
8	LOCKWASHER 5/8, Ø.647 ID X Ø1.079 OD X .156 THK	4
9	FLAT WASHER, 5/8" ID X 1.750 OD X .134 THK, GR. 5, BZ	4
10	LOCKNUT FLANGE SERRATED 1/2 -13, GR F, CZ	8
11	1/2-13 UNC X 1.5 WHEEL BOLT, GR. 5, CZ	8
12	5/8-11 UNC X 6.00 CARRIAGE HEAD BOLT, GR5, BO	2
13	HEX HEAD BOLT 5/8-11 X 3.5", GR5, BZ	4
14	PULL WIRE, 1/2" X 23.5" LONG	2
15	TUBE, DOM, 1.125" OD X .875" ID X .125" WALL X 2.4375" LONG	2
16	U-SHAPED BRACKET	2
19	NUT, HEX 5/8 -11 GR5, CZ	2

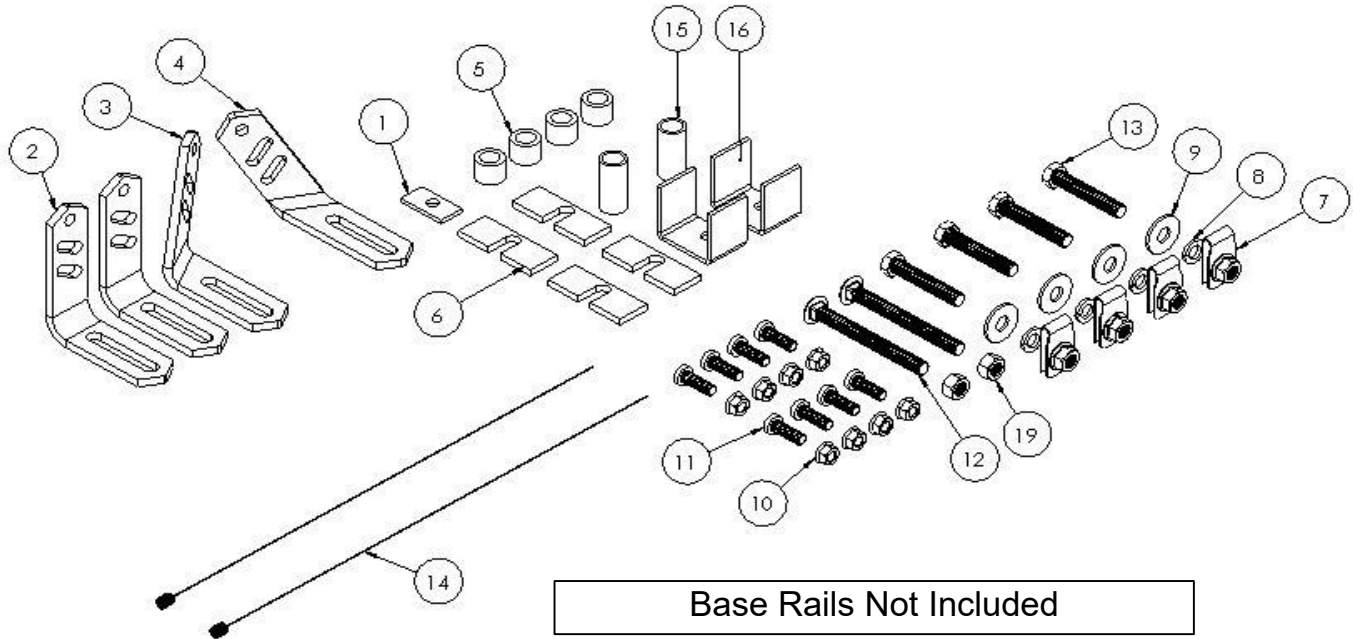

Base Rails Not Included

1. Place the two bed rails across the truck bed between the wheel wells. Position the 5th wheel uprights between the bed rails so that the tabs in the base of each upright will fit into the slots in the ends of the bed rails. Secure the uprights in place with the rail hitch pins and hair pins supplied with the 5th wheel installation kit. Securely attach 5th wheel cross member to uprights.

2. On most applications, the 5th wheel assembly should be positioned so that it is approximately centered over the truck axle and between the wheel wells on the bed floor.

NOTE:
To keep the trailer from hitting the cab on tight turns there must be at least 52" between the hitch and the cab. On long bed pickups the hitch center line can be up to 3" ahead of the axle. On short bed pickups this position is not possible. A 5th wheel hitch that can move the trailer rearward away from the truck cab should be used with a pickup truck bed length less than 8 ft, consult the Husky Towing Products catalog to select the product that best matches your needs.

DO NOT USE WITH TRUCKS THAT HAVE BED LENGTHS SHORTER THAN 6 FT.

3. When hitch is correctly positioned in the bed and the bed rails are parallel, mark four attachment points on the truck bed using whichever one of the three (3) 5/8" rectangular slots at the ends of each bed rail line up best with the truck frame. Check below the bed before drilling holes to see that all wiring, brake lines or other obstructions are moved out of the way and will not be contacted by the drill. Move the hitch assembly out of the way and drill four (4) 3/16" diameter pilot holes down through the bed at the previously marked points. Check under the bed where the (4) 3/16" pilot holes and ensure that when the brackets are placed up against the frame they will line up. Then drill these holes to 5/8" diameter.

4. Reposition the bed rails in the bed so that the rectangular 5/8" slots in the end of each rail are lined up over the drilled holes. Place a 1" thick spacer tube #5 under ends of each bed rail, in line with the drilled holes as shown on Illustration 1.

Item # 5

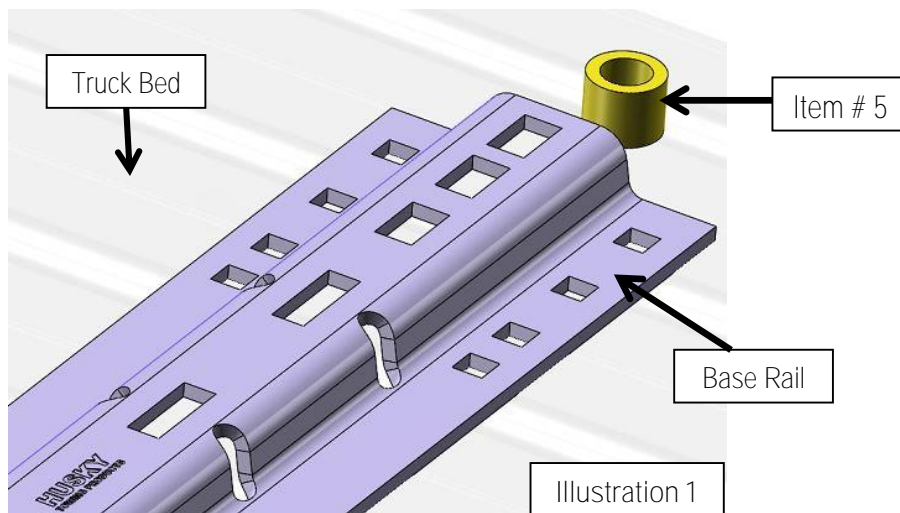

5. If the bed corrugation above the angle bracket is UP, leaving a space above the angle bracket, place a spacer plate #6 in this location as shown on Illustration 2. If the corrugation is DOWN, at this location, place a spacer plate #6 in the bed, under the base rail as shown on Illustration 2. Bolt parts loosely in place as illustrated.

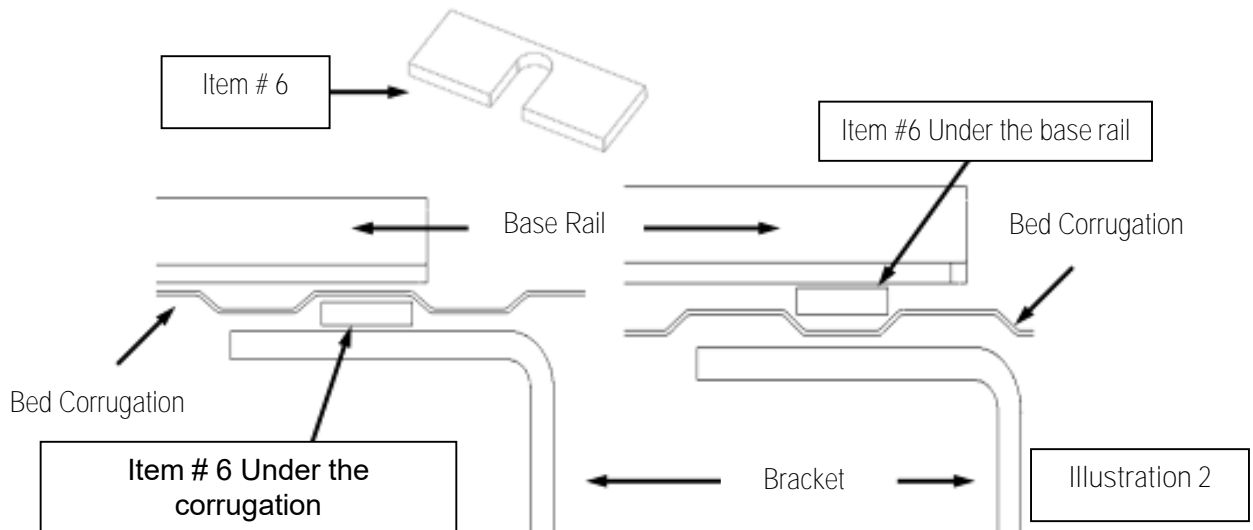

6. Position one of the angle brackets under the bed and align with the 5/8" hex bolts #13, protruding down through the bed. Use the left and right angle brackets at locations where frame obstructions will not allow the straight "L" brackets to be positioned. If frame is clear of obstructions, the angle brackets may be placed at any location.

7. Move the installed straight "L" or angle brackets so that they rest tightly against the flat side of the truck frame and underneath surface of truck bed. Install the 5/8" hardware down through bed rails and brackets. See page 4 for Illustrations "3" & "4".

NOTE: There are two lengths of 5/8" hex bolts #12 (long) or #13 (short). Use the shorter bolts on applications where vehicle frame clearance may be close to attachment point. Bolts can be used in any attachment location. Securely bolt brackets in place. Be sure they are tight against the side of truck frame. Hand tighten the 5/8" bolts.

8: Install the 5/8"-11 hex head bolts & 5/8" hardware provided in the Husky Custom Bracket kit.

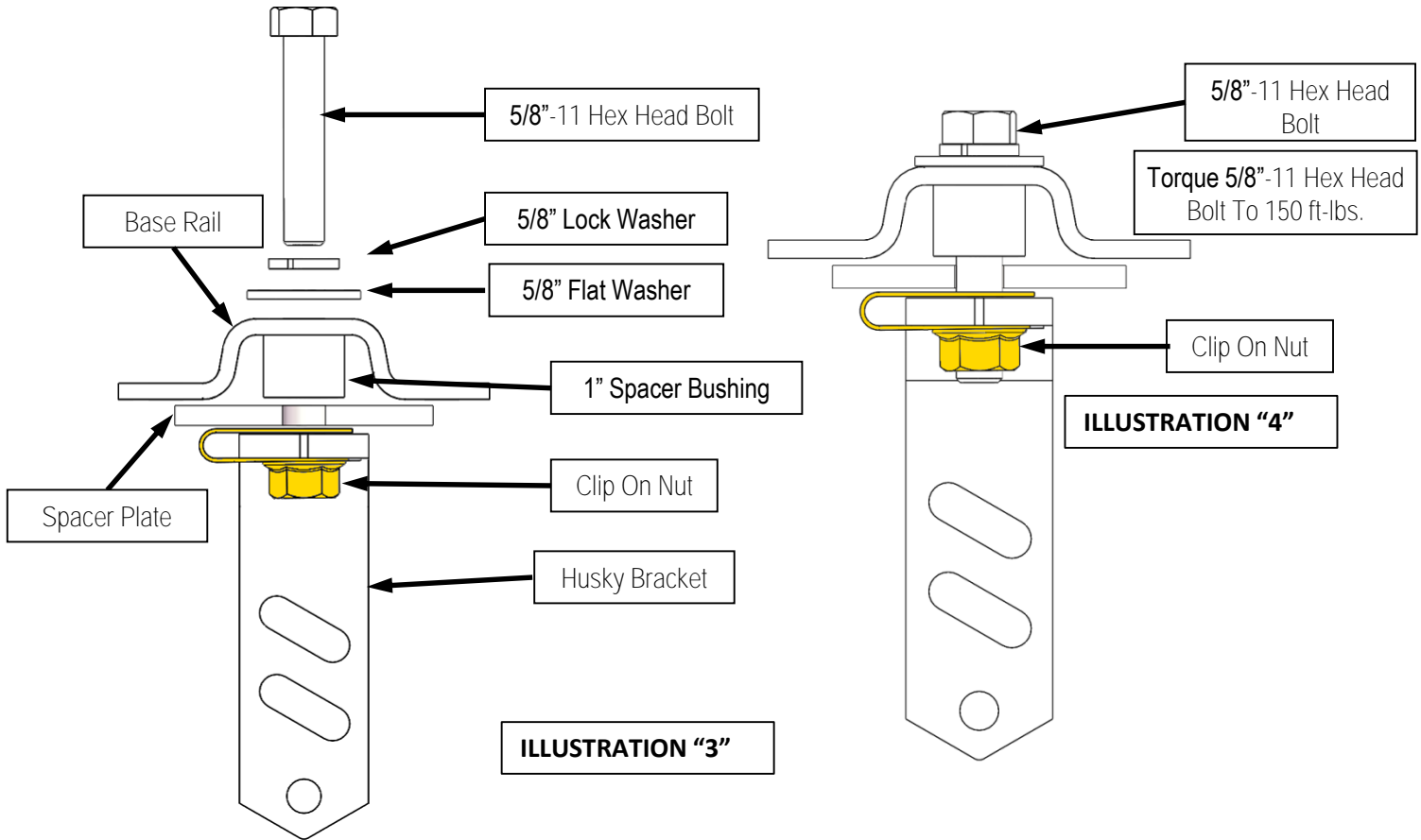

9: Torque the 5/8"-11 hex head **bolt** to 150 ft-lbs. **DO NOT** apply torque to the nut portion of the clip on nut. **You will DAMAGE it.**

10. Before drilling any holes, check inside the frame to be sure that there are no wires, brake lines or other obstructions in the frame which may be contacted by the drill. Each of the brackets must be attached to the side frame of the truck with two (2) special 1/2" wheel bolts #11. Drill two 3/16" pilot holes through the side of the truck frame using two of the holes in each angle bracket as guides then enlarge to 17/32" diameter. If possible use the bottom hole and the top angled slot for attaching the brackets to the frame with the serrated bolt.

CAUTION: Holes **MUST** be drilled 17/32" diameter, so that the special wheel bolts will seat properly. If holes are too small, the bolt may break. If hole is too large it will not grip properly. See Illustration "A". You can apply some grease to the splines only of the wheel bolts to ease the installation into the holes in the frame.

SPECIAL NOTE: On 1999 to 2010 Chevrolet Silverado and GMC Sierra applications, it will be necessary to modify the bolt installation procedure on the forward driver side bracket attachment. Drill a 5/8" diameter frame attachment hole at the lower bracket attachment point. Place one of the 1/2" wheel bolts #11 in the 3/16" spacer plate #1. Place this bolt assembly into frame so that the threaded end of bolt protrudes out through frame. Bolt bracket in place at this location. See Illustration "B". The remaining bracket bolts will install as shown on Illustration "A".

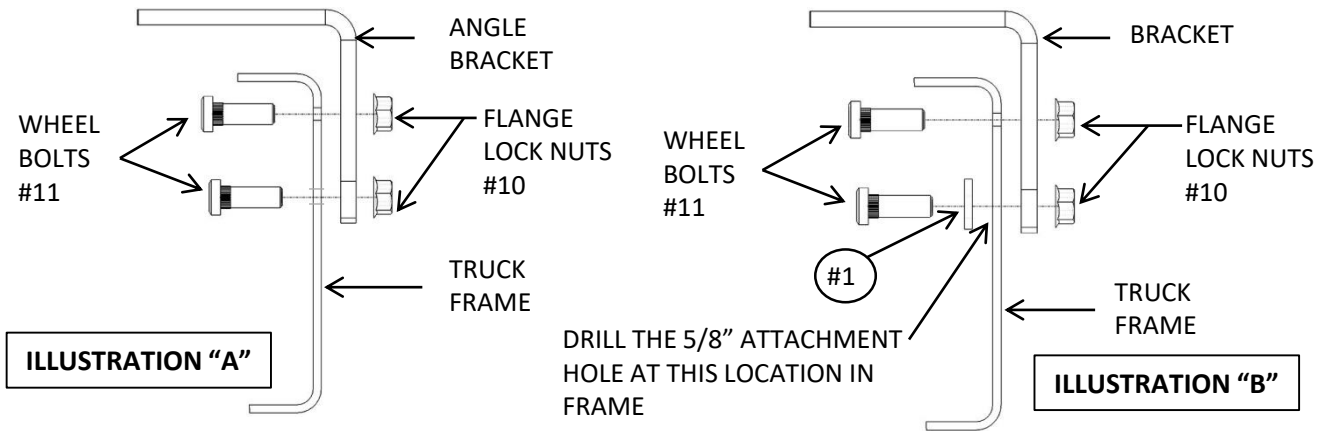

11. Place the wheel bolts into the frame first and then out through the brackets. See Illustration "A". Some applications will require the use of a pull wire to align the bolts into the drilled holes in the frame. Thread the pull wire coil #14 over the end of the wheel bolt #11 and pull through frame and bracket. See Pull Wire Illustration. Secure each bracket to the truck frame. The knurled portion of the bolts will lock into the frame holes as the nuts are tightened. Use of an air wrench will make installation much easier.

12. Tighten all 1/2" attachment bolts to 75 ft. lbs. torque.

13. Check each rail hitch pin for freedom of movement in the bed rail connection. Remove the (4) base rail pins and lift the hitch uprights up out of the bed rail slots. If tabs are tight in bed rail slots check to be sure the bedrails are parallel to one another and square. If not, loosen 5/8" bolts and adjust the bed rails. Also, check that the uprights are sitting straight vertically. It may be necessary to shim the uprights by placing a shim between it and the cross member channel. See Illustration "C".

14. Re-tighten 5/8" hardware to 150 ft. lbs. torque.

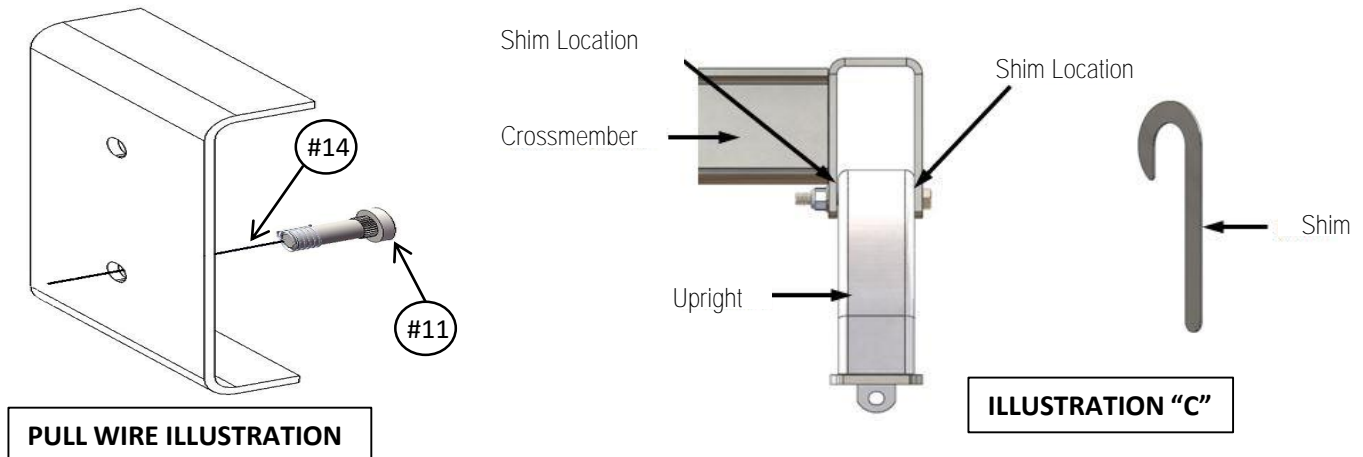

5TH WHEEL INSTALLATION TIPS BY VEHICLE

Due to variations in vehicle assembly through the years listed, the under bed hat section location on your truck may not be the same as listed below. The following information is to be used as a suggestion for placement of the bed rail system. Slight adjustments to these positions may be required.

FIT	VEHICLE	4 BOLT RAIL DIST. (III, H)	10 BOLT RAIL DIST. (III, H)	INSTRUCTIONS
FIT1	1987 - Older Chevrolet S, GMC C/K Long Bed: (Approx. 3-1/2" ahead of axle installation.)	33-5/8"	33-3/16"	Left, right angle and frame brackets may be placed where ever brackets fits best. Note:The left and right angle bracket can be mounted on either side of the truck if needed.
FIT2	1987 - older Chevrolet & GMC C/K Short Bed: (Over the axle.)	23-5/8"	23-3/16"	Left, right angle and frame brackets may be placed where ever brackets fits best. Note:The left and right angle bracket can be mounted on either side of the truck if needed.
FIT3	1988 - 2000 Chevrolet/GMC C/K Long Bed P/U (over axle installation)	29-7/8"	29-7/16"	The left and right angle brackets may be placed at whatever location will give the best attachment points on the truck side frame. Use angle brackets opposite of opposing shock absorbers.
FIT4	1988 - 1999 Chevrolet/GMC C/K Short Bed P/U (over axle installation)	24-318"	23-15/16"	Check clearance between front of trailer and back of truck Cab. If there is Not enough clearance at this location, install the Husky roller (32220) or Husky Glider(32042 or 31196), which will allow rearward movement of the fifth wheel during maneuvering operations. See Illustration "I"
FIT5	1999 - 2010 Chevrolet/GMC Silverado/Sierra Long Bed P/U (Approx. 1"ahead of axle installation)	31-1/2"	31-1/16"	The left and right angle brackets will be placed at the rear attachment points and the straight brackets will be at the forward attachment points The front frame to bracket attachment bolts will need to be fish wired into the forward box frame section. The left and right angle brackets may be placed at whatever location will give the best attachment points on the truck side frame. Use angle brackets opposite of opposing shock absorbers. See special Note on Page 3 Step 8.
FIT6	1999 - 2010 Chevrolet/GMC Silverado/Sierra Short P/U Bed P (Approx. 1"behind axle installation)	24"	23-9/16"	The left and right angle brackets will be placed at the forward attachment points and the straight brackets will be at the rear attachment points. The front frame bracket attachment bolts will need to be fish wired into the forward box frame section. Use the 5/8" x 3-1/2" bolts at the forward base rail attachment points and the 5/8" x 3-1/2" bolts at the rear base rail
FIT7	2011 - 2012 Chevrolet/GMC 2500 HD and 3500 HD Silverado and Sierra (Short Bed Pickup)	25-5/8"	25-3/16"	Install the straight "L" brackets at the front position and the angled "L" brackets at the rear as shown below.
	2011 - 2012 Chevrolet/GMC 2500 HO and 3500 HD Silverado and Sierra (Long Bed Pickup)	30-1/8"	29-11/16'	Install the straight "L" brackets at the front position and the angled "L" brackets at the rear as shown below.
F1T8	1993-Earlier Dodge P/U Full Size (2"ahead of axle installation)	32-1/2"	32-1/16"	The left and right angle brackets can be positioned at any location that will allow them to clear obstructions on the truck frame.
FIT9	1994-2001 1500 / 1994-2002 2500 & 3500 Dodge Full Size Long Bed: (Approx. over axle installation)	28-7/8"	28-7/16"	Use the frame brackets to attach the rear rail to the frame. Fasten down with 5/8" x 6" hex bolts, serrated washers and nut. When pulling in the 1/2"" serrated bolts, use the access hole in the top or bottom of the frame if needed.

FIT	VEHICLE	4 BOLT RAL DIST. (Ill. "H")	10 BOLT RAL DIST. (Ill. "H")	INSTRUCTIONS
FIT10	1994-2001 1500 / 1994-2002 2500 & 3500 Dodge Full Size Short Bed: (Approx. over of axle installation)	24-3/4"	24-5/16"	Use the frame brackets to attach the rear rail to the frame. For the front rail you will have to drill a 1-1/4" hole through the Bed sill using a hole saw. Let the pilot bit of the hole saw make a dimple in the top of the frame rail. Drill a 21/32" hole down through the top frame rail using the dimple from the hole saw as a guide. Fasten down with 5/8" x 6" hex bolts, flat washer, lock washer and nut. When pulling in the 1/2" serrated bolts, use the access hole in the top of the frame if needed.
FIT11	2002 - 2013 Dodge 2500 / 2002-2012 Dodge 3500 Long & Short Beds			Requires Adapter Kt 30607 (Install Instructions in Kit).
FIT12	2002 - 2008 Dodge 1500			Requires Adapter Kt 30640 or 30607 (Install Instructions in Kt).
FIT13	2009 - 2015 Dodge 1500			Requires Adapter Kt 30665 (Install Instructions in Kit).
FIT14	1973-1991 Ford F- Series (over axle installation) Long Bed	28-518"	28-3/16"	Use the left and right angle brackets to clear the shock mount brackets on the side of the truck frame, at the rear attachments. On some Ford Short Bed applications or other trucks with frame obstructions, the use of four angle brackets can ease installation. Reference either the Coast or Husky Towing catalog to order the kit which includes the left and right angle brackets.
	1973-1991 Ford F- Series (over axle installation) Short Bed	29-3/4"	29.5/16"	Use the left and right angle brackets to clear the shock mount brackets on the side of the truck frame, at the rear attachments. On some Ford Short Bed applications or other trucks with frame obstructions, the use of four angle brackets can ease installation. Reference either the Coast or Husky Towing catalog to order the kit which includes the left and right angle brackets.
FIT15	1992 - 1996 Ford F-150 & F-250 P/U - 1997 -1998 F-250 HD (over axle installation) (Long Bed)	28-5/8"	28-3/16"	This will place both of the hitch Bed rail attachment points to the rear of both truck under Bed cross members. Use the left and right angle brackets to clear the shock flaut brackets when attaching to the side of the truck frame.
	1992 - 1996 Ford F-150 & F-250 P/U - 1997 - 1998 F-250 HD (over axle installation)(Short Bed)	29-3/4"	29-5/16"	This will place both of the hitch Bed rail attachment points to the rear of both truck under Bed cross members. Use the left and right angle brackets to clear the shock mount brackets when attaching to the side of the truck frame.
FIT16	1997 1998 Ford F-350 P/U (behind axle installation) (Long Bed)	26-3/4"	26-5/16'	Due to some heavy duty suspension components on various models of this truck, the assembled 5th wheel must be positioned to the rear of the axle centerline.

FIT	VEHICLE	4 BOLT RAIL DIST. (Ill. "H")	10 BOLT RAIL DIST. (Ill. "H")	INSTRUCTIONS
	1997 - 1998 Ford F-350 P/U (behind axle installation) (Short Bed)	27-3/4"	27-15/16"	Due to some heavy duty suspension components on various models of this truck. the assembled 5th wheel must be positioned to the rear of the axle centerline
FIT 17	1997 2004 Ford F-150 & F-250 P/U (except HD F-250 & 2004 F150 new body)(over axle installation) Long & Short Bed	26-3/4"	26-5/16"	Some installations may position the base rails so that the attachment holes are drilled down through the front under Bed reinforcement channel and the truck frame. Use the (2) 2-7/16" Long tube spacers for the forward base rail mounting and use the angled brackets from this kit for the rear locations
FIT18	1999 - 2002 Ford F 250 & F 350 Super Duty (over axle installation) Long & Short Bed	28-1/4"	27-13/16"	If the truck is equipped with overload springs, the spring bracket on the side of the frame will have to be temporarily removed. Holes in the frame and spring brackets must be enlarged to accept 1/2" bolts. Use the straight brackets on the front base rail and the angled brackets at the rear base rail. The rear angle brackets will line up with the previously removed overload spring brackets. Reinstall the spring brackets on top of the angle brackets. The rear spring bracket attachment points will require 3/8" thick spacers and Longer 1/2" bolts (not supplied) to install.
FIT19	1997 - 2003 Ford F-150 (and '04 Heritage Model) & F-250 LD (over the axle installation) Long & Short Bed	26-3/4"	26-5/16"	Attach the left and right angled frame brackets to the rear Fifth wheel rail Note The left and right angle bracket can be mounted on either side of the truck if needed Then attach the frame bracket to the front Fifth wheel rail
FIT20	1992 - 2004 Ford F-250 & F-350 Short & Long Bed (1/2" rearward of Axle Center installation)	30-5/8"	30-3/16"	Place straight brackets under the forward base rail and the angled brackets under the rear rail with the angle going rearward.
FIT21	2004 - 2014 Ford F150 (except '04 Heritage Model). 6' & 8' Beds	29-5/16"	28-7/8"	Attach the left and right angled bracket to the rear base rail and the straight brackets to the front base rail
FIT22	2000 - 2014 Ford F150 (except '04 Heritage Model). 6' & 8' beds.	27-3/8"	26-15/16"	Requires Adapter Kt 30619. When installing the 5/8" base rail bolts use the middle slots on the forward rail and the inside slots on the rear rail. Ensure the base rails are spaced 22" apart center to center and that they are parallel before marking your hole to drill through the rails. Use a 9/16" drill for bolts that go through frame and a 5/8" drill for the base rail bolts to go through the truck Bed Caution: Make sure that the area below the Bed being drilled is clear before drilling holes.
FIT23	2005 - 2015. Ford F-250, F-350 & F-450 Superduty Pickup (Not Cab Chassis)			Requires Adapter Kit 30607 (Install Instructions in Kit).
FIT24	1999 - 2006 Toyota Tundra Long & Short Bed Rl) (over axle installation)	30-7/8"	30-7/16"	The left and right angle brackets will be placed at the forward attachment points and the straight brackets will be at the rear attachment points.

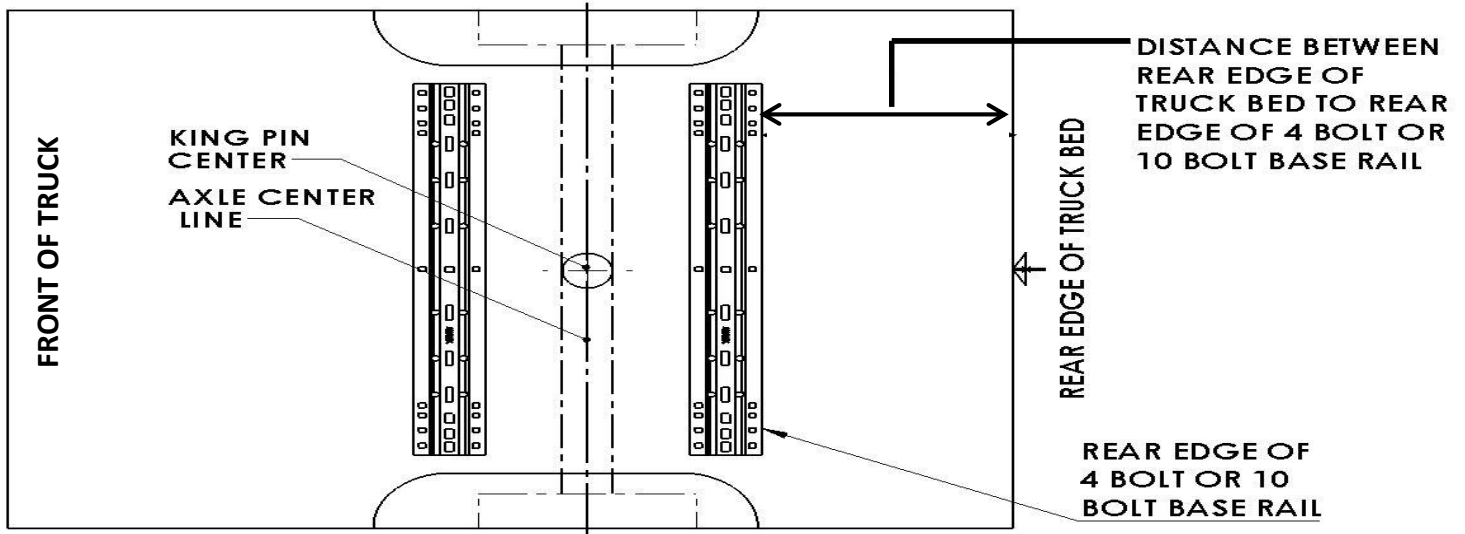

ILLUSTRATION "H"

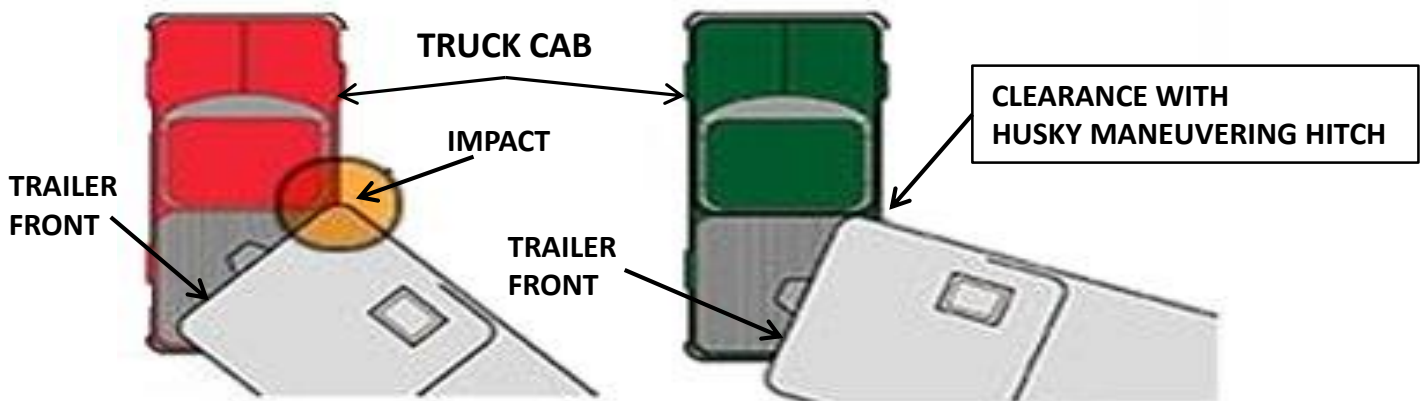
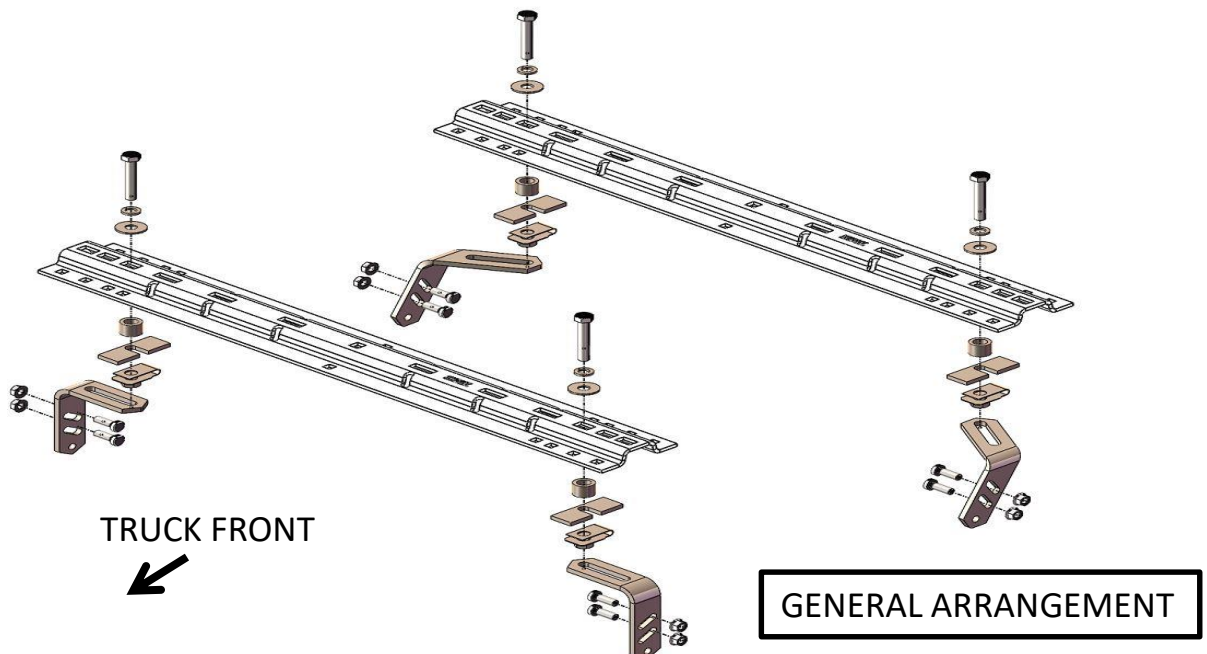

ILLUSTRATION "I"

NOTE:

THE POINTS WHERE FRONT BASE RAIL MOUNTING BRACKET ATTACHED CALLED FRONT ATTACHMENT POINTS & THE POINTS WHERE REAR BASE RAIL MOUNTING BRACKET ATTACHED CALLED REAR ATTACHMENT POINTS.



Warranty Terms:

5 Year Limited Warranty:

This warranty applies solely to Husky 5th Wheel Installation Kits manufactured by LKQ Specialty Products Group for Husky Towing Products.

Husky Towing Products and LKQ Specialty Products Group make no guarantees or warranties for products not manufactured by LKQ Specialty Products Group. Such products are covered solely under any applicable warranty of the manufacturer. It is always recommended that the operating instructions and guarantee instructions provided by the manufacturer are followed.

LKQ Specialty Products Group warrants its products to be free from manufacturing and material defects to the original purchaser for the length of warranty stated above from the date of retail purchase. If any products are found to have a manufacturing or material defect, the product will be replaced or repaired at the option of Husky Towing Products and LKQ Specialty Products Group with proof of purchase by the original purchaser. The original purchaser shall pay all transportation and shipping costs associated with the return of the defective product and the defective product shall become the property of LKQ Specialty Products Group.

The Warranty applies to LKQ Specialty Products Group products used for individual and recreational purposes. Commercial usage of the LKQ Specialty Products Group products limits the warranty to 90-days from date of purchase.

The Warranty applies only to LKQ Specialty Products Group products which are found to be defective in manufacturing or material. This warranty does not apply to normal wear and tear of the finished placed on LKQ Specialty Products Group products.

Husky Towing Products and LKQ Specialty Products Group are not responsible for any labor costs incurred for removal or replacement of the defective product.

Husky Towing Products and LKQ Specialty Products Group are not responsible for repair or replacement of any product under the limited warranty where the product was improperly installed, misapplied, altered, abused, neglected, overloaded, misused or damaged as a result of an accident, including any use of the product not in accordance with all product operating and safety instructions.

Without limiting the generality of the foregoing, Husky Towing Products and LKQ Specialty Products Group shall under no circumstances be liable for any incidental or consequential loss or damage whatsoever arising out of, or in any way relating to any such breach of warranty or claimed defect in, or non-performance of the products. Some states do not allow the exclusion or limitation of incidental or consequential damages, so the above exclusion or limitation may not apply to you.

This limited warranty gives you specific legal rights, and you may also have other rights that vary from state to state.

If you're looking for quality trailer hitches & towing, visit our website.