



## Assembly, Installation, Operation and Maintenance Instructions

**P/N: 31407**

### No Drill Ford Super Duty Bracket Kit

<b>Dealer / Installer:</b>	Provide a copy of these Instructions to the end user of this product. These Instructions provide important operating and safety information for proper usage of this product. Demonstrate the proper use of the product with the end user. Have the end user demonstrate that they understand the proper use of the product.
<b>End User:</b>	Read and follow all instructions included in this manual. Ask your Dealer / Installer for assistance if you do not understand the proper use of the product. Never remove any decals from the product.

**NOTE:** This bracket kit can be used with the 31323 4 Bolt or 30686 10 Bolt Bed Rail Kit.

**DO NOT EXCEED Recommended towing limits. SEE VEHICLE'S OWNER'S MANUAL.**

Item No.	Description	Quantity
1	Bracket, Right Frame - Weldment	1
2	Bracket, Left Frame - Weldment	1
3	Spacer Bed 1/4" Thick	4
4	Spacer Tube 1" Thick	4
5	Spacer Frame 1/2" Thick	2
6	Spacer Frame 1/4" Thick	2
7	Bolt, Carriage 1/4 -20 X 1-1/4	1
8	Flat Washer (1/4)	1
9	Lock Washer (1/4)	1
10	Hex Nut (1/4)	1
11	Bolt, Hex Head 9/16 -12 X 1-3/4"	2
12	Flat Washer (9/16)	4
13	Lock Washer (9/16)	2
14	Hex Nut (9/16 -12)	2
15	Bolt, Hex Head 5/8" -11 X 3.25"	4
16	Flat Washer (5/8)	4
17	Lock Washer (5/8)	4
18	Clip Nut (5/8 -11)	4
19	Bolt, Hex Head 3/4" -10 X 2-1/2"	2
20	Flat Washer (3/4)	4
21	Lock Washer (3/4)	2
22	Hex Nut (3/4 -10)	2

#### Tools Required

3/4" Socket/Wrench	1/4" Drill Bit
13/16" Socket/Wrench	9/16" Drill Bit
15/16" Socket/Wrench	5/8" Drill Bit
Drill	Torque Wrench

Base Rails Not Included

**WARNING!** Never exceed the towing capacity of the tow vehicle.

**Center Bolt Kit 32059 (sold separately) must be used when towing with a 26K hitch, Goose Neck, or Maneuvering System.**

**CAUTION:** Do not install base rails over plastic bed liners. Plastic bed liners must be cut out of the way. Rails may be installed on spray in liners. Consult spray liner installer for recommended curing time.

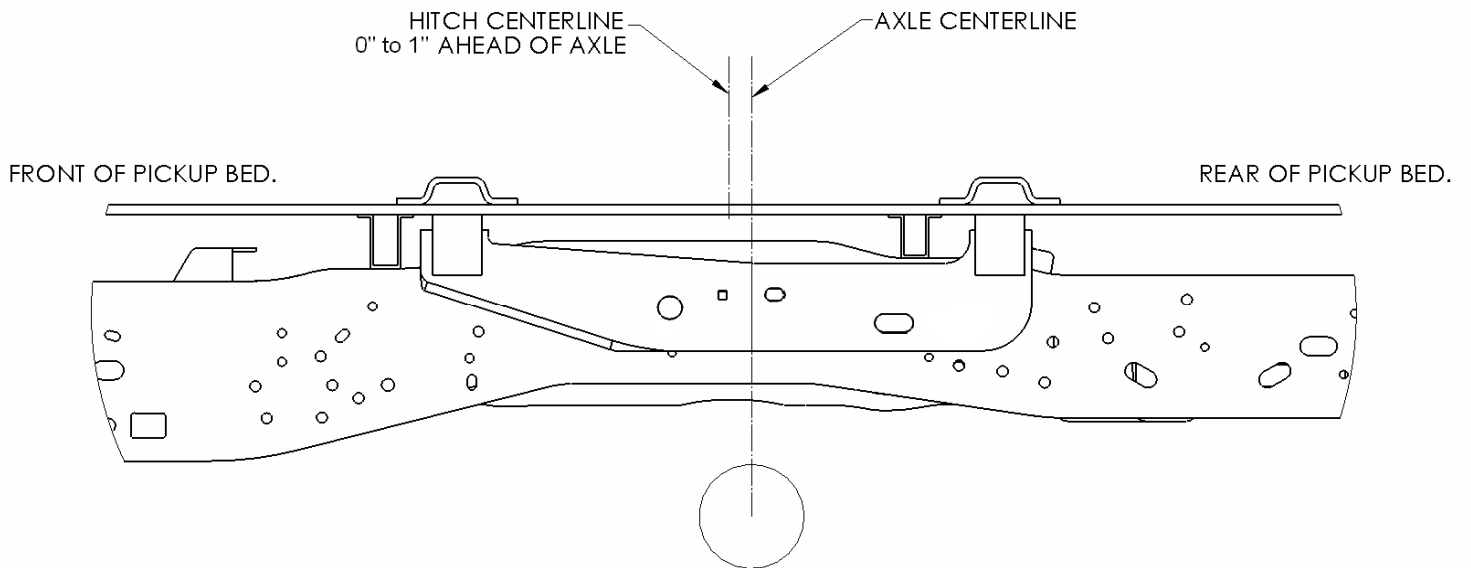
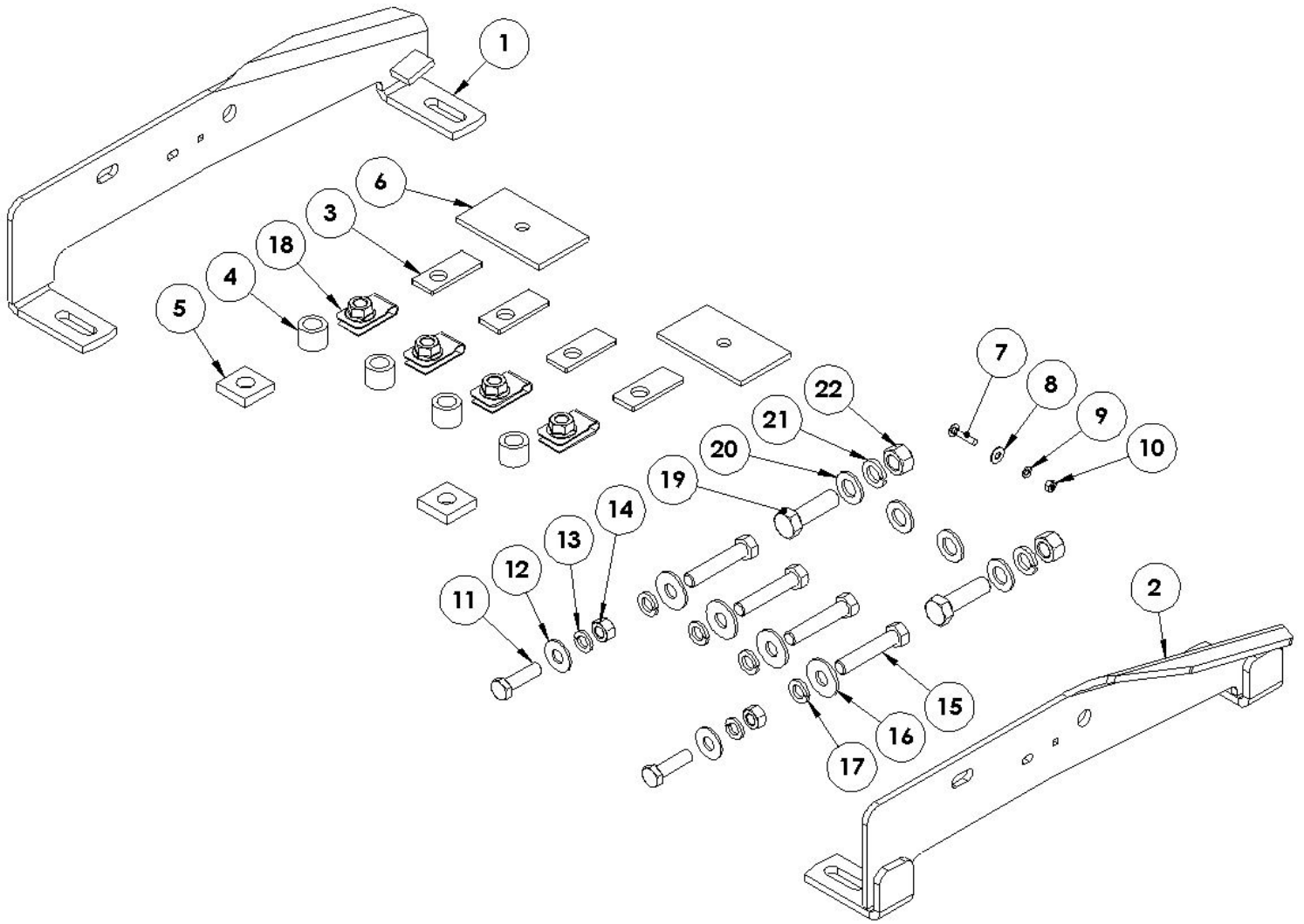

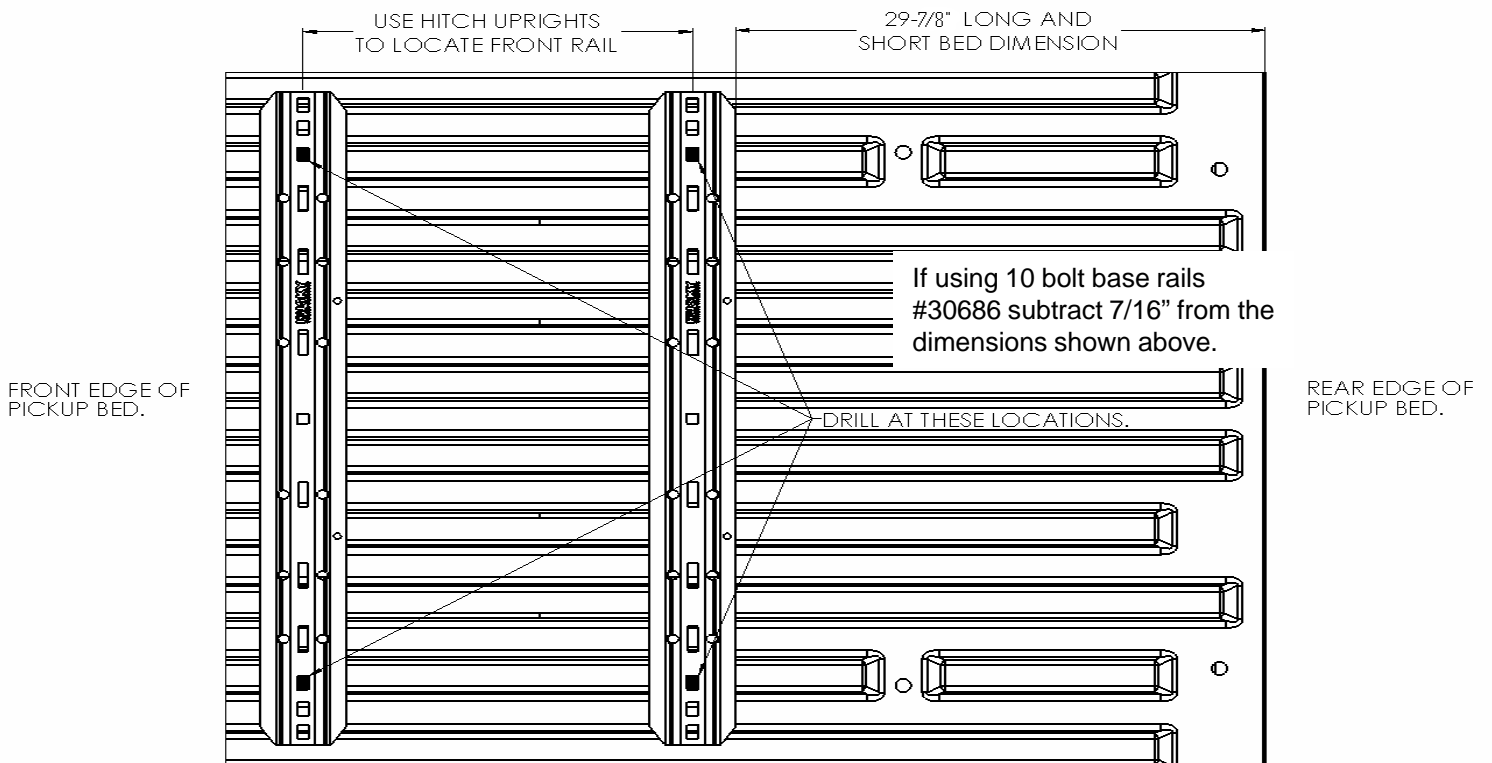

1. On some trucks there will be a brake cable hanger on the side of the frame where the frame bracket will be attached. Remove the brake cable hanger from outer surface of truck frame. The cable hanger will be re-installed later.
2. Position the right and left frame brackets #1 and #2 against their appropriate side of truck frame as shown on Illustration 1.

**NOTE:** On models where the cable hanger has been removed from frame, place the 1/4" carriage bolt (#7) through the left frame bracket before placing the bracket against the frame. See Illustration 2. The threaded end of the bolt should be extending out from the frame bracket. Place the brake cable hanger over the carriage bolt and secure as shown on Illustration 2. Be sure that the free end of the hanger is positioned into the locator slot in frame mount bracket, before tightening nut

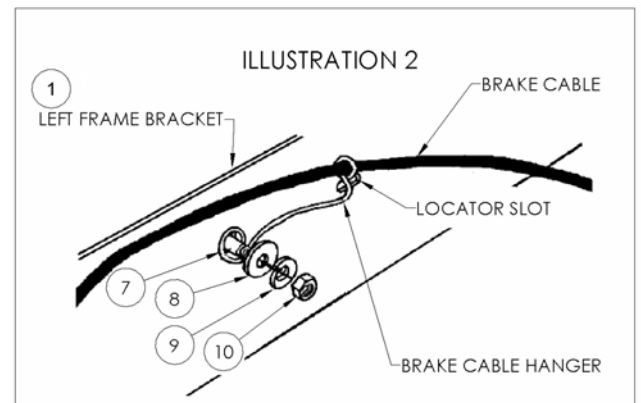
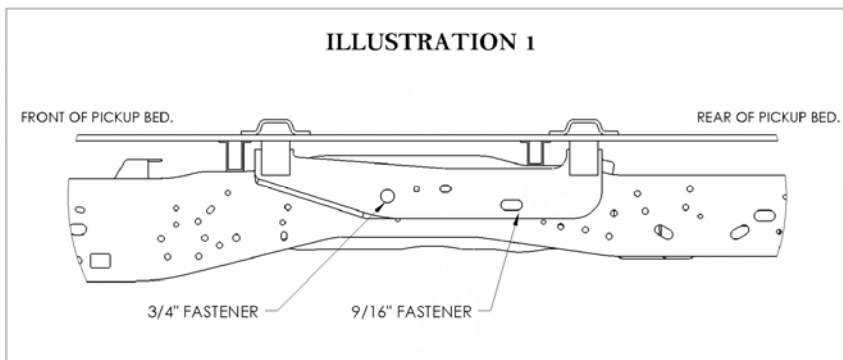

3. Place a 3/4" Hex bolt (#19) and 3/4" washer (#20) through the truck frame slot at the center attachment point in frame bracket. Place a 1/2" thick spacer plate (#5) on bolt between the truck frame and the frame bracket, as shown on Illustration 3. Bolt in place with a 3/4" flat washer (#15), 3/4" Lock washer (#16), and 3/4" hex nut (#17).
4. Place the 1/4" thick spacer plate (#6) inside each truck frame in line with the rear attachment hole. Position this plate with 5" dimension up and down in frame. Bolt reinforcement plates (#6) and frame brackets to frame with 9/16" fasteners as shown on Illustration 4. Do not tighten fasteners at this time.

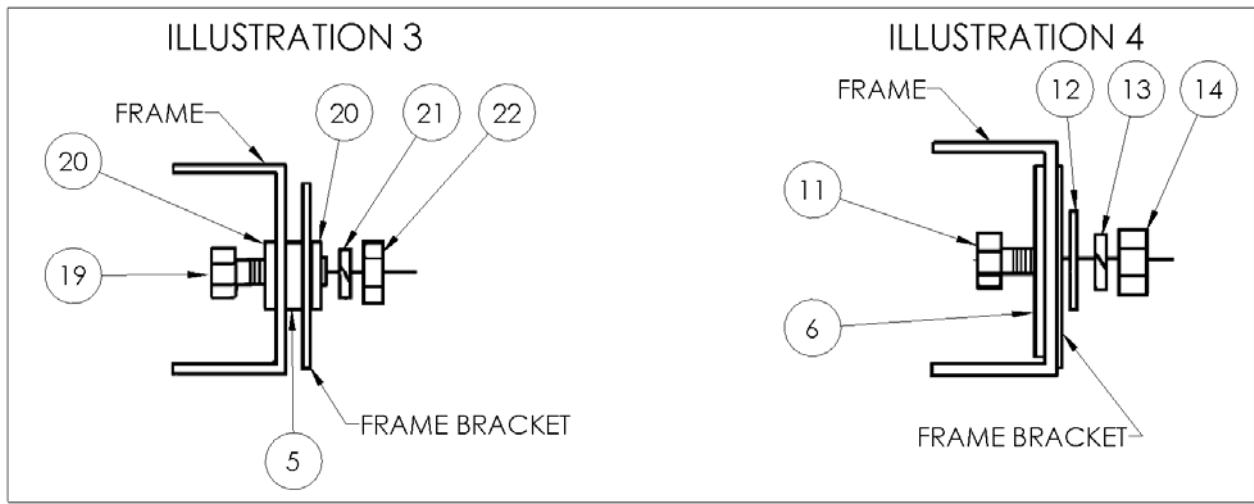

5. Place the two bed rails across the truck bed between the wheel wells. Position the 5<sup>th</sup> wheel uprights between the bed rails so that the tabs in the base of each upright will fit into the slots in the ends of the bed rails. Secure the uprights in place with the rail hitch pins and hair pins supplied with the 5<sup>th</sup> wheel installment kit. Securely attach 5<sup>th</sup> wheel cross member to uprights.
6. Position the bed rail assembly in truck bed as shown on the layout illustration on page 2 of this instruction sheet. When hitch is correctly positioned in the bed and the bed rails are parallel, mark four attachment points on the truck bed using the 5/8" square holes indicated on the layout Illustration on Page 3 of this document.
7. Check below the bed before drilling holes to see that all wiring, brake lines or other obstructions are moved out of the way and will not be contacted by the drill. Drill 1/4" pilot hole through bed floor at each previously marked location. Check to see that these holes line up with installed frame bracket mounting tabs. Adjust hole location as needed. Move the hitch assembly out of the way and drill four 5/8" diameter attachment holes down through the bed at the previously marked points.
8. Reposition the bed rails in the bed so that the square 5/8" hole in the end of each rail is lined up over the drilled holes. Place a 1" spacer tube (#4) under ends of each bed rail, in line with the drilled holes. See Illustration 5.

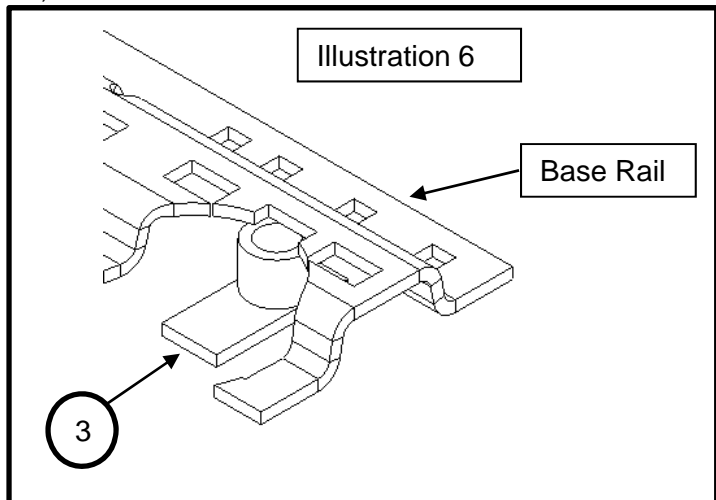
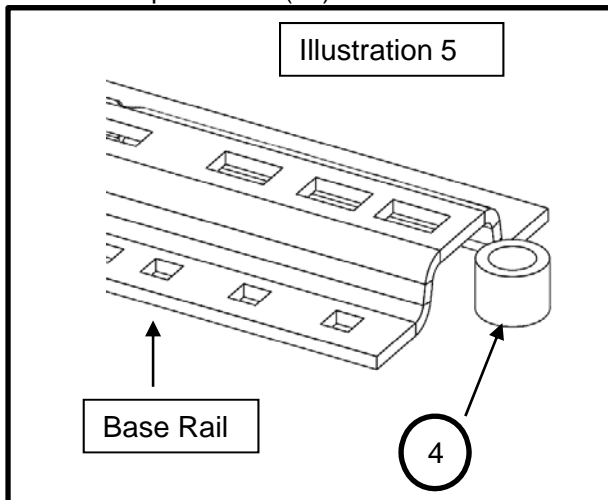

9. If the bed corrugation above the frame bracket is UP, leaving a space above the frame bracket, place a spacer plate (#3) in this location as shown on Illustration 6. If the corrugation is DOWN, at this location, place a spacer plate (#3) in the bed, under the base rail as shown on Illustration 6a. Bolt parts loosely in place as shown on Illustration 7

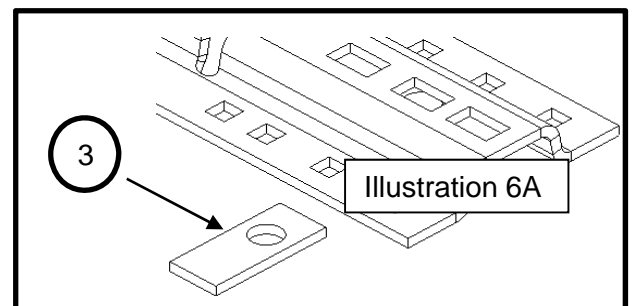

10. Tighten all 1/4" attachment bolts to 8 ft.-lbs. torque, all 1/2" attachment bolts to 75 ft.-lbs. torque, all 9/16" attachment bolts to 110 ft.-lbs. torque, and all 3/4" bolts to 260 ft.-lbs. torque. Failure to tighten bolts as described may result in fastener loss or failure.

11. Place 5/8-11 hex bolt(#15) through 5/8 Lock washer(#17), 5/8 flat washer (#16) and through base rail slot, tube spacer (#4), Spacer plate (#3), truck bed corrugation and bracket flange slot. Secure bolt with clip nut (#18) as shown in illus.7 & 7A.

12. Tighten each 5/8" bed rail attachment bolt to 150 ft.-lbs. torque. Failure to tighten bolts as described may result in fastener loss or failure. DO NOT apply torque to the nut portion of the clip nuts (#18). You will DAMAGE it.

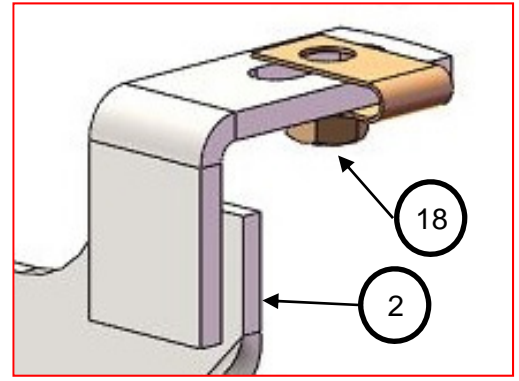

Illustration 7A

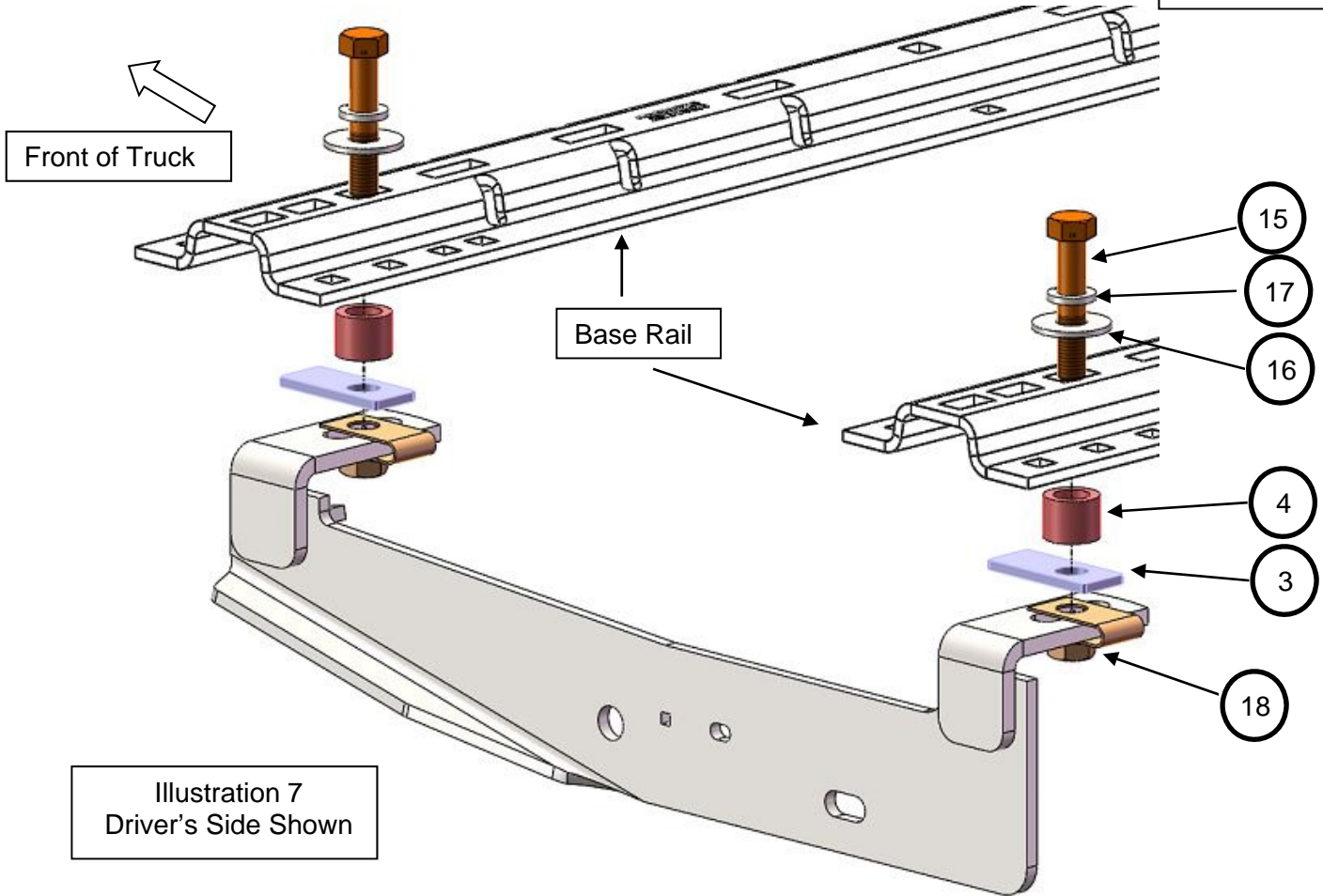

Illustration 7  
Driver's Side Shown

13. Check each rail hitch pin for freedom of movement in the bed rail connection. Adjust uprights, if necessary, by placing a shim between the upright and the cross member to obtain free pin movement. See Illustration 8.

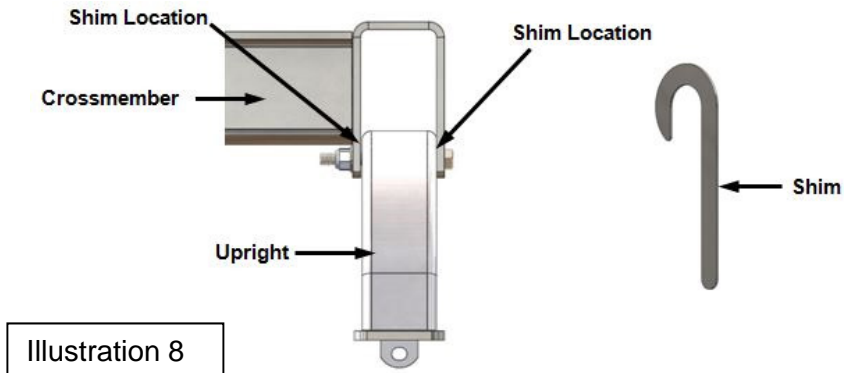

Illustration 8

# Warranty Terms:

## 5 Year Limited Warranty:

This warranty applies solely to Husky 5<sup>th</sup> Wheel Installation Kit manufactured by LKQ Specialty Products Group for Husky Towing Products.

Husky Towing Products and LKQ Specialty Products Group make no guarantees or warranties for products not manufactured by LKQ Specialty Products Group. Such products are covered solely under any applicable warranty of the manufacturer. It is always recommended that the operating instructions and guarantee instructions provided by the manufacturer are followed.

LKQ Specialty Products Group warrants its products to be free from manufacturing and material defects to the original purchaser for the length of warranty stated above from the date of retail purchase. If any products are found to have a manufacturing or material defect, the product will be replaced or repaired at the option of Husky Towing Products and LKQ Specialty Products Group with proof of purchase by the original purchaser. The original purchaser shall pay all transportation and shipping costs associated with the return of the defective product and the defective product shall become the property of LKQ Specialty Products Group.

The Warranty applies to LKQ Specialty Products Group products used for individual and recreational purposes. Commercial usage of the LKQ Specialty Products Group products limits the warranty to 90-days from date of purchase.

The Warranty applies only to LKQ Specialty Products Group products which are found to be defective in manufacturing or material. This warranty does not apply to normal wear and tear of the finished placed on LKQ Specialty Products Group products.

Husky Towing Products and LKQ Specialty Products Group are not responsible for any labor costs incurred for removal or replacement of the defective product.

Husky Towing Products and LKQ Specialty Products Group are not responsible for repair or replacement of any product under the limited warranty where the product was improperly installed, misapplied, altered, abused, neglected, overloaded, misused or damaged as a result of an accident, including any use of the product not in accordance with all product operating and safety instructions.

Without limiting the generality of the foregoing, Husky Towing Products and LKQ Specialty Products Group shall under no circumstances be liable for any incidental or consequential loss or damage whatsoever arising out of, or in any way relating to any such breach of warranty or claimed defect in, or non-performance of the products. Some states do not allow the exclusion or limitation of incidental or consequential damages, so the above exclusion or limitation may not apply to you.

This limited warranty gives you specific legal rights, and you may also have other rights that vary from state to state.