



Installation Instructions Competition Plus Shifter

To be used with Shifter Installation Kit#3738609, Sold Separately

Catalog# 3918794

WORK SAFELY: Perform this on a good clean level surface for maximum safety and with the engine turned "off". Apply parking brake and place blocks or wedges in front of and behind both rear wheels to prevent movement in either direction.

CAUTION: To avoid any possibility of bodily injury or damage to vehicle, do not attempt disconnect or installation until you are confident that the vehicle is safely secured and will not move.

IMPORTANT

The bolts that fasten the stick to the shifter and the bolts that are used as gear stops are SAE grade 5 bolts. If the bolts need to be replaced, make sure they are SAE grade 5.

NOTE: The stiffener plate is used with all shifters except those which have tapped holes. Both methods are shown below.

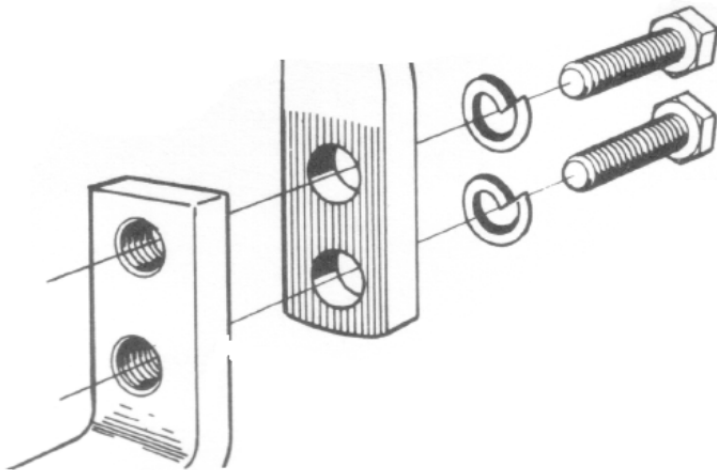

Stick bottom with tapped holes do not require stiffener plate.

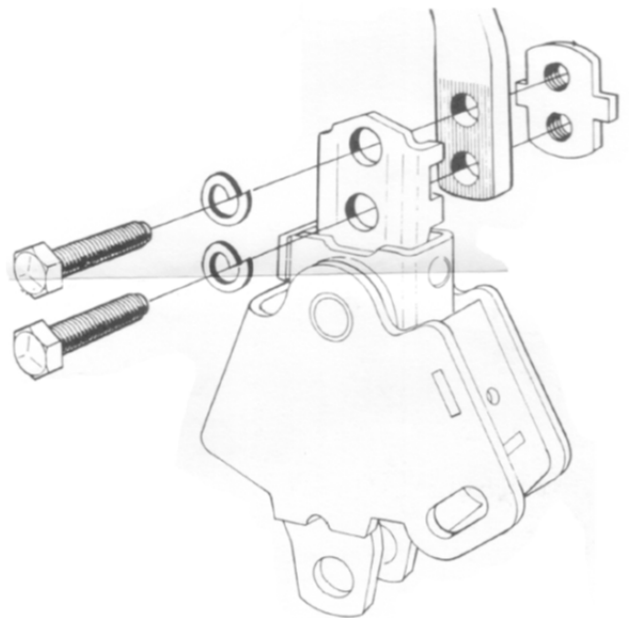

Standard stick configuration requires the use of a stiffener plate.

Serration of stick mesh with serrations in shifter mount.

