

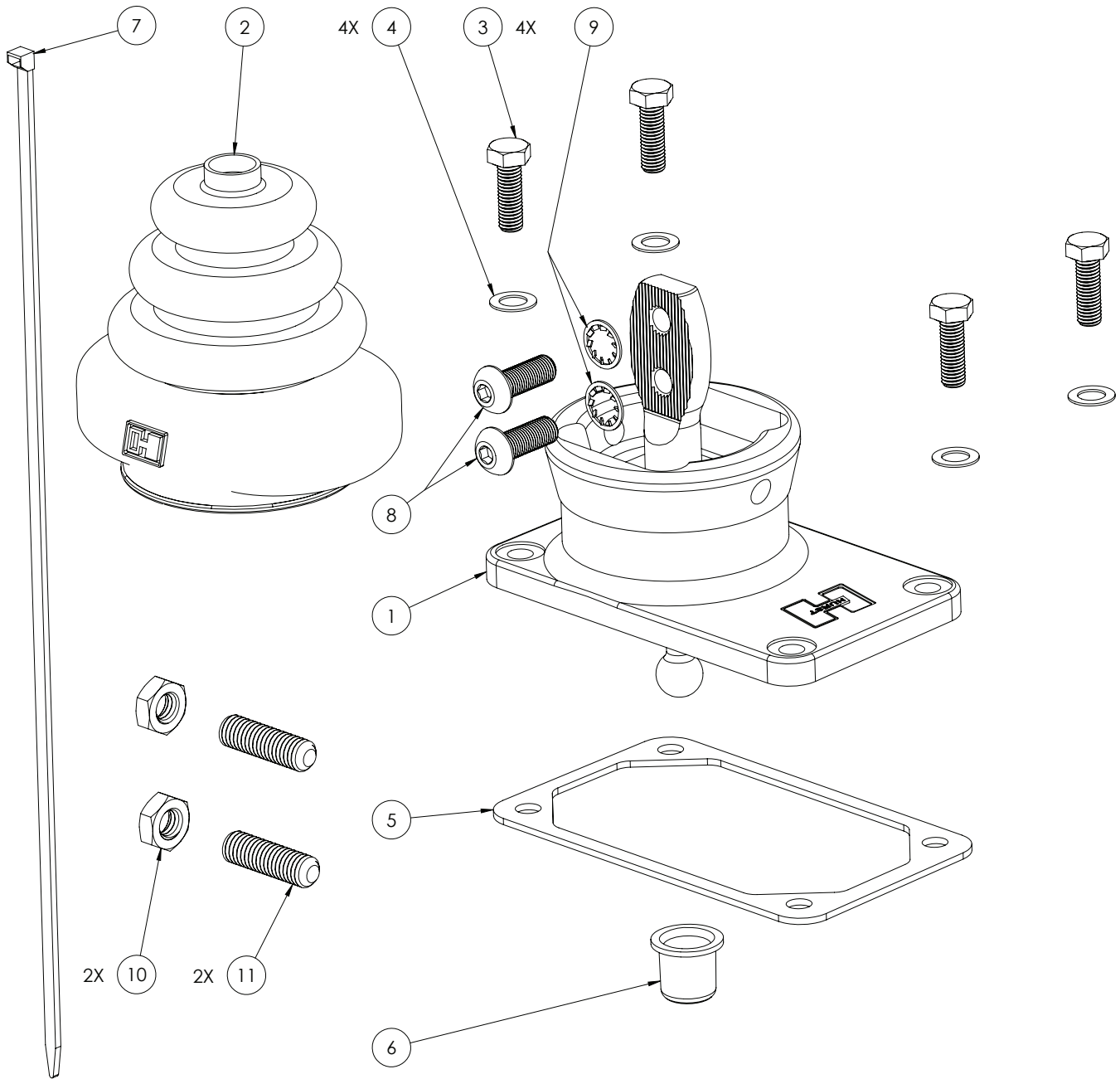

Installation Instructions
BLACKJACK™ SHIFTER
3916051
 1983-04 FORD BORG-WARNER T5/T45
 & TREMEC T5 TRANSMISSIONS



ITM #	PART #	DESCRIPTION	QTY.
1	3916051	Shifter Assembly	1
2	1145001	Dust Boot	1
N/A	3916051BA-01	Hardware Package includes:	1
3	3400729	M8 x 1.25 x 25 Bolt	4
4	2675000	.375 x .625 Flat Washer	4
5	1950020	Spacer Plate	1

ITM #	PART #	DESCRIPTION	QTY.
6	4101278-00	Cup	1
7	3401669	Zip Tie	1
8	2158808	3/8-24 x 1 Screw	2
9	2673533	3/8" Lock Washer	2
10	2155001	7/16-14 Jam Nut	2
11	2155002	7/16-14 x 1.50 Set Cup Screw	2

HURST FLAT & ROUND BAR BOLT-ON SHIFTER STICKS:

The Hurst Blackjack Shifter for the Borg-Warner T-5/T-45 Mustang transmission accommodates any Hurst bolt-on shift stick. Hurst shift sticks are available in a variety of configurations where particular heights or off-sets are required. Constructed from high-strength, chrome-plated steel and feature the iconic Hurst name stamped on both sides. The sticks feature 3/8-16 threads to accept most popular Hurst T-handles and classic white or black shift knobs.

OVERVIEW:



1. Please take a moment to read and understand instructions before beginning install.

NOTE: Please inventory all parts before starting the installation process and call our tech line to report any missing parts. This will help avoid potentially stranding your vehicle until any missing replacement parts arrive.

WARNING: For maximum safety, perform installation on a clean, level surface with engine turned off.

CAUTION: To avoid bodily injury or vehicle damage, chock wheels and do not attempt installation until you are confident your vehicle will not move.

DISASSEMBLY:

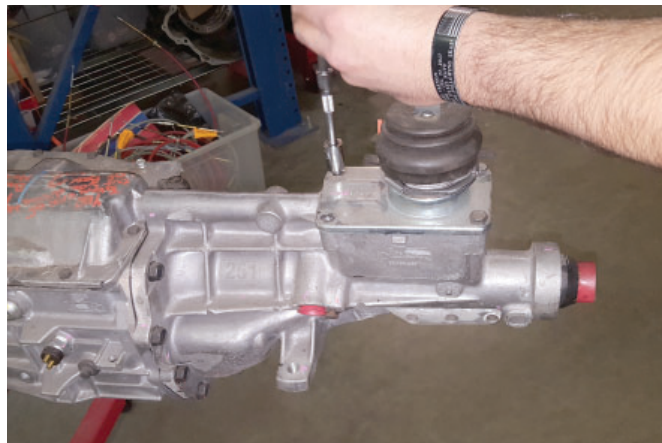

2. Put transmission in NEUTRAL. Remove (x4) shifter bolts then break sealant bond between shifter and mount pad. Remove shifter.

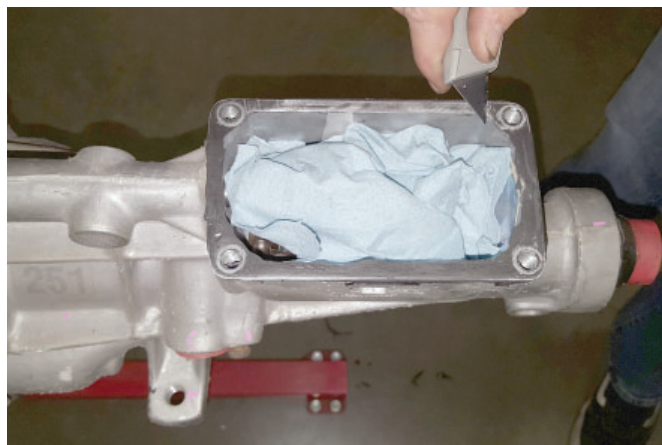

NOTE: Cover transmission to prevent any debris from falling into it.

3. Scrape old sealant from shifter mount pad, then wipe with brake cleaner.

INSTALL HURST BLACKJACK SHIFTER:

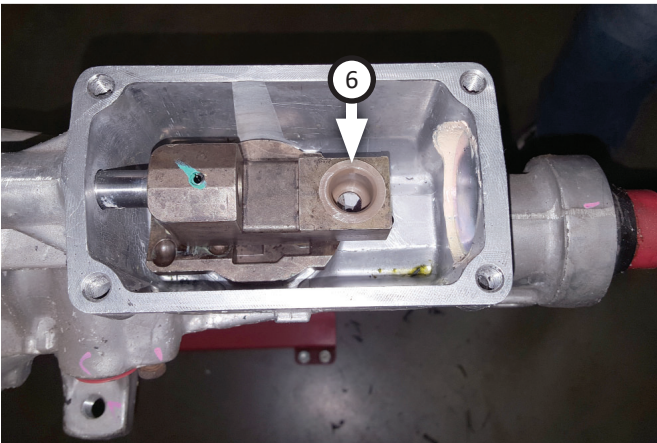

4. Place **cup (6)** into offset lever then apply grease to inside of it. Then apply $\frac{1}{8}$ " bead of RTV silicone sealant around shifter mount pad

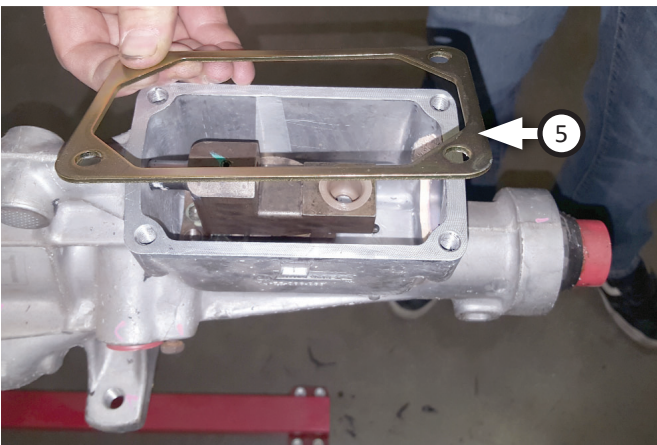

5. If you have a T-45 transmission, place **spacer plate (5)** onto transmission as shown.

NOTE: Once installed, apply more sealant to top of spacer as well.



6. Guide shift rod ball into cup and place **shifter (1)** on pad.

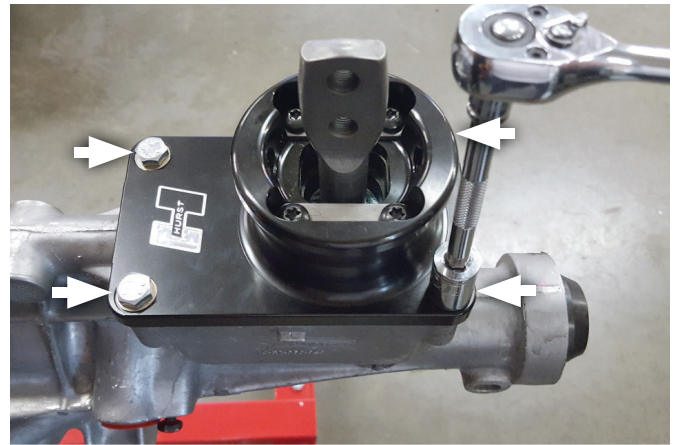

7. Secure shifter to transmission with (x4 ea.) **bolts (3)** and **flat washers (4)**, tightening them evenly to 12-15 ft-lbs torque.

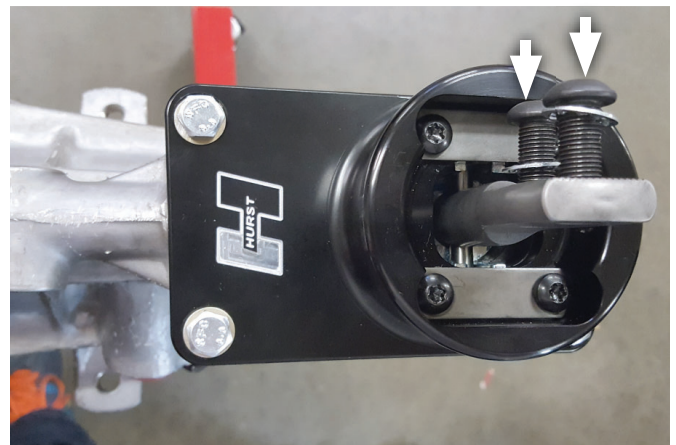

8. Apply thread locking compound to each screw then thread (x2 ea.) **bolts (8)** and **lock washers (9)** through your shifter stick.

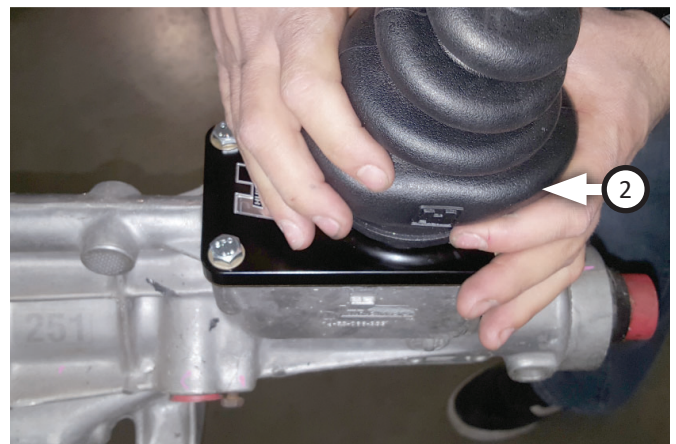

9. Fit **dust boot (2)** onto transmission over bolts and washers.



10. Install **dust boot (2)** over the shift stick and slide down onto the tower. Secure to tower with **zip-tie (7)**.

NOTE: Included lock washers are single-use only; replace them if stick is ever removed from shifter.

STOP SCREWS:

After extensive testing with various race teams, as well as continuing development with the original transmission Engineering group, we have determined that the “shift stop” feature is redundant on T-Series of Borg-Warner (Tremec) transmissions.

WARNING: If you feel that your style of driving requires the use of shift stops, install (x2) **jam nut (10)** and **set cup screw (11)** before step 9. Then adjust fasteners exactly as described or internal transmission damage could occur!

STOP SCREW ADJUSTMENT:

1. Pull shifter back into fourth gear.
2. Turn stop screw in with your fingers until it contacts lower shifter stick.
3. Turn stop screw out ½ a turn.
4. Hold stop screw with a ⅜" Allen key then tighten jam nut securely with an ⅞" box or open end wrench.
5. Push shifter firmly into third gear and repeat process with front stop screw. Lock it in place with jam nut.

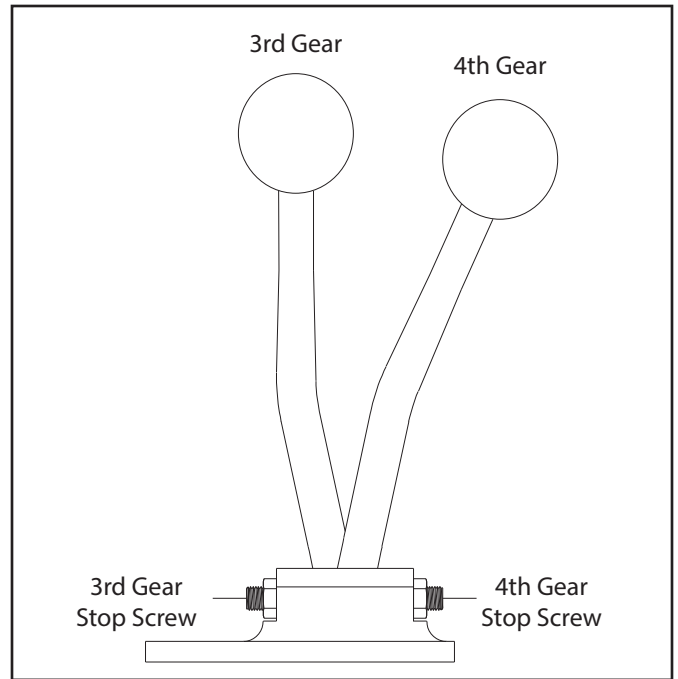

Congratulations, the installation of your Hurst Blackjack Shifter is now complete!

