



**Installation Instructions**  
**COMPETITION/PLUS® SHIFTER**  
2015-2017 Ford Mustang  
MT82 6-Speed Manual Transmission  
Catalog# 3916037

**WORK SAFELY!** For maximum safety, perform this installation on a clean, level surface and with the engine turned off. Place blocks or wedges in front of and behind both rear wheels to prevent movement in either direction.

**CAUTION:** To avoid any possibility of bodily injury or damage to vehicle, do not attempt installation until you are confident that the vehicle is safely secured and will not move.

**IMPORTANT**

Please compare the contents of the package against the parts list below to ensure that you have all necessary components before beginning the removal and disassembly of your factory shifter. Contact customer service with any questions regarding packaged components. Because this is a relatively complex installation please refer to our website for a detailed installation video that is available on YouTube.

**PARTS**



**Chrome Upper Stick**



**Classic Hurst White Knob**



**Lower Stick**



**Shift Rod**



**Trigger Rod**



**Reverse Lock-Out Collar**



**Cotter Pin**



**1/4" Flat Washer**



**3/8" Lock Washer (2)**



**Guide Nut**



**Spring Bracket**



**Spring**

**Parts (cont.)**



**Spring Retaining Screw**



**8-32 Set Screw**

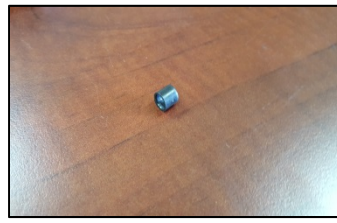

**Link Bushing**



**Jam Nut**



**3/8" Washer**



**Rear Mount**



**3/8"-24 Cap Screw**

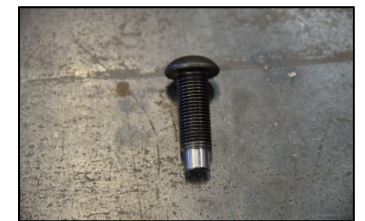

**3/8"-24 Guide Screw**



**Pivot Bolt**



**1/4"-20 Screw**



**Link (2)**



**1/4" Shoulder Screw**



**1/4" Disc Spring**



**1/4" Flange Bearing**



**10-24 Lock Nut**



**Swivel Link**



**3/16" Shoulder Screw**



**8/32 Lock Nut**



**Tie Wrap**

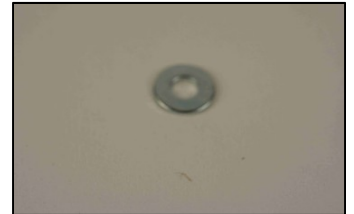

**#8 Washer**



**3/16" Disc Spring**



**Nylon Washer**



**Fiber Washer**

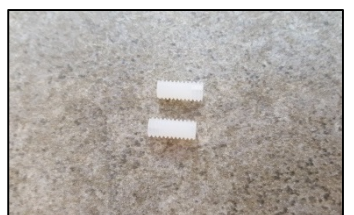

**Nylon Set Screw (2)**



## TOOLS



Plastic Trim Remover (2 Pry Tool)



4mm Punch



Hammer



T-20 Torx Driver

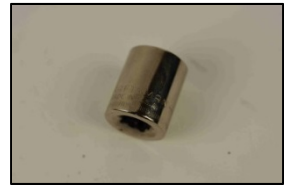

18mm Socket



Breaker Bar



1/4" Drive Ratchet



10mm Sockets



Extension



Universal Joint



13mm Socket



11/32" Wrench



1/8" Allen Wrench



Craft Knife



7/32" Wrench



Phillips Screwdriver



5/64" Allen Wrench



3/32" Allen Wrench



Torque Wrench  
(20-80 ft.lbs)



15mm Socket



7mm Socket



Jack



Jack Stands



10mm Wrench



10mm Ratchet Wrench



Disc Grinder



Plastic Hammer

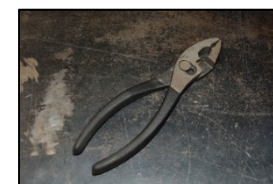

Pliers



Vise



C-Clamp

## Tools (cont.)



3/8" Drive Ratchet



3/4" Socket



7/16" Socket



Side Cutters

## Disassembly

1. Unscrew the shift knob.  
(counter-clockwise to remove.)



2. Remove the front driver side and passenger side panels from the center console.

Tool: Plastic Trim Remover



3. Remove the two (2) screws from both sides of the console.

Tools: 7mm Socket, Extension, Ratchet



4. Remove the center console. Start by lifting up the rear and work your way up to the front.

Tool: Plastic Trim Remover x 2



5. Unplug the harness from the console. Set the console aside.



6. Unsnap the shift boot bezel from the console. Lift from the top to release the top clips and then use the pry tool to un-clip the rest. Now you can remove the center console.

Tool: Plastic Trim Remover



7. Remove the leather boot. There are three clips holding the boot to the reverse lock out sleeve, use a screw driver to pry one clip at a time while pulling up on the boot. Set boot aside for reinstallation later.





8. Remove the white plastic washer and black O-ring. Then remove the spring retaining roll pin followed by the spring.

Tools: 4mm Punch, Hammer



9. Remove the retaining screw and then remove the factory reverse lockout sleeve.

Tool: T20 Torx Driver



10. Lift the vehicle. Support the vehicle with Jackstands if working with a floor jack.



11. Although this step is not required it makes for ease of removal and installation. Support the mid-section of the exhaust. Loosen the nuts at the two exhaust connections just behind the transmission. Move the system to the rear and let the system hang in place.

Tools: 15mm socket



12. Support the transmission.

Tools: transmission stand or floor jack



13. Remove the four (4) 18mm bolts securing the transmission to the frame. Lower the rear of the transmission. Support the rear with a transmission stand if you have the vehicle supported with a lift; support the rear with a floor jack if you have the vehicle supported with jack stands.

Tools: Breaker Bar, 18mm Socket, Ratchet, Extension



14. Remove the three (3) 15mm bolts securing the crossmember to the transmission.

Tools: Breaker Bar, 15mm Socket, Ratchet



15. Remove the three (3) 18mm bolts securing the front end of the driveshaft to the transmission.

**IMPORTANT:** Make an alignment mark between the Flex Coupling and the transmission flange. You must re-install the driveshaft in the same position as it was removed.

Tools: 18mm Socket, Ratchet

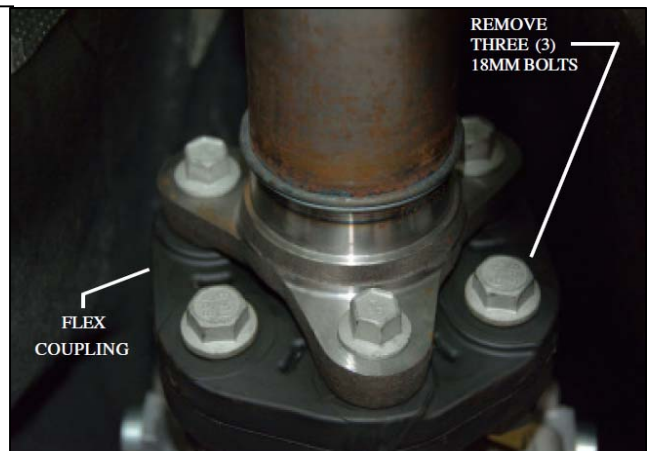



16. Remove the center bearing bolts.

Tools: 13mm Socket, Ratchet

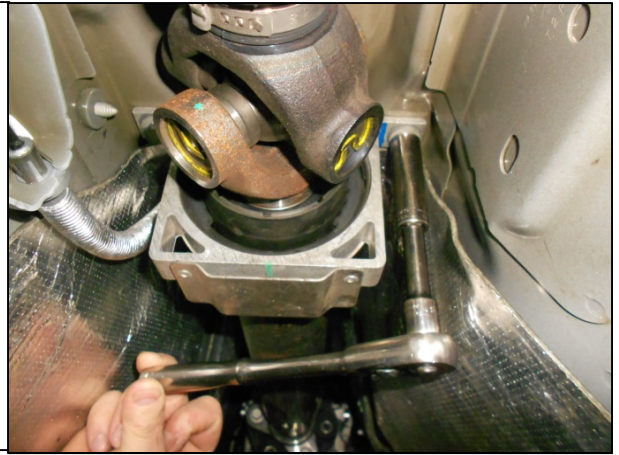

17. Once the center bearing bolts have been removed, you can pull the driveshaft back and lower the front end of the driveshaft. Allow the driveshaft to rest on top of the exhaust.

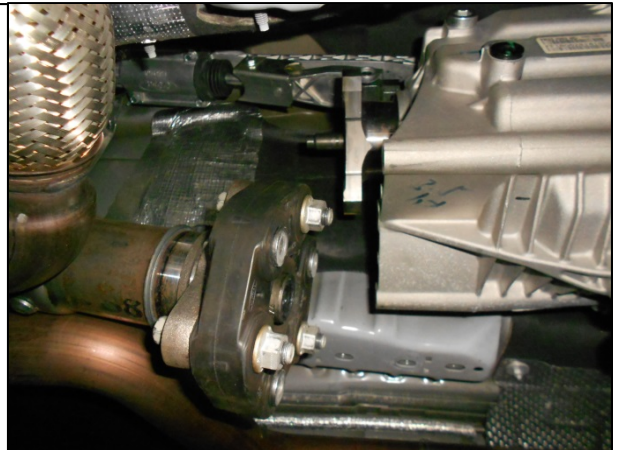

18. Remove the two (2) 10mm hex nuts that mount the rear of the shifter to the transmission tunnel.

Tools: 10mm Deep Socket, Universal Adapter, Extension(s), 1/4" Drive Ratchet



19. Remove the bolt attaching the shifter housing to the transmission.

Tools: a 10mm ratchet wrench makes for ease of removal.

Remove the bolt from the side of the transmission. You may have to pull down on the transmission to allow the screw to clear the tunnel.

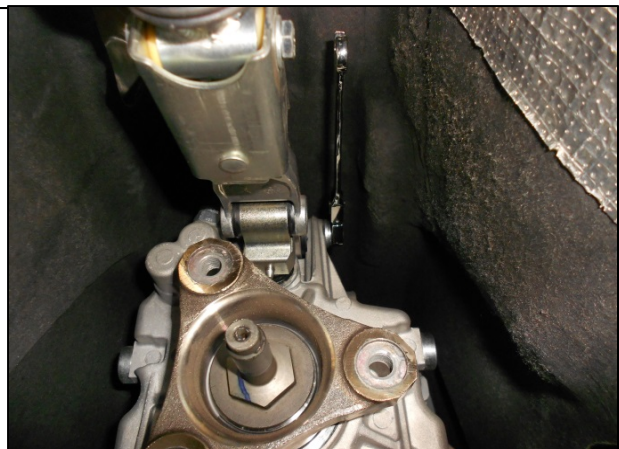



20. Remove the shift linkage bolt.

Tools: 13mm Socket, 3/8" Drive Ratchet



21. The photo to the right is a close up of the bolt removed from the shift linkage. Note that the bolt is only partially threaded at the top. This is being mentioned so you don't spend too much time trying to loosen a bolt that is already completely loose. After it is completely loose, it will need to be pulled free.



22. The shifter housing assembly can now be removed and set on a clean working surface.



23. Remove the rubber boot from the shifter housing.

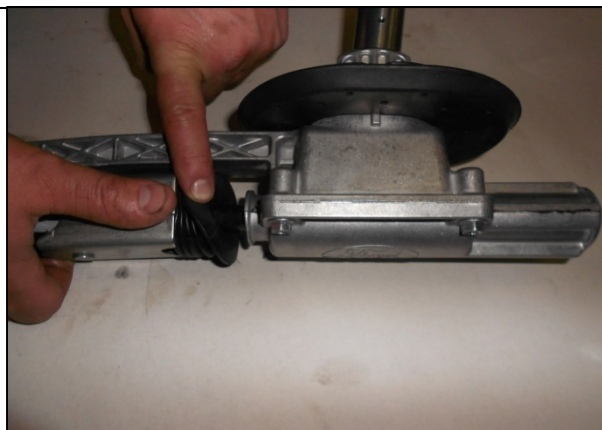

24. Remove the (4) 10mm bolts securing the bottom plate to the shifter housing.

Tools: 10MM Socket



25. Remove the bottom Plate. Take care when removing the bottom plate, there is a rubber gasket that will be reused.



26. This is a photo of what the internal components of the shifter look like.

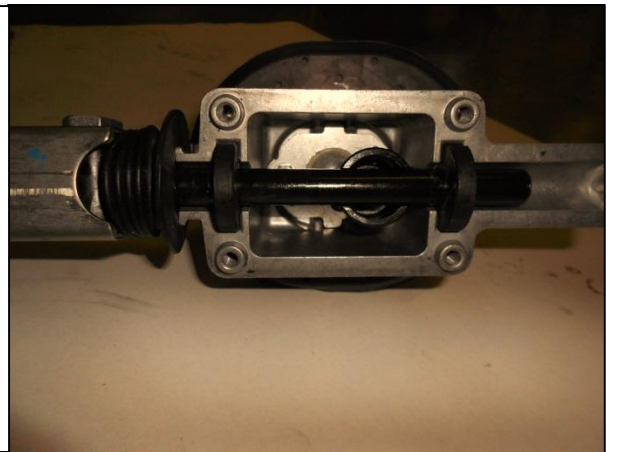

27. Remove the shift rod from the shifter housing.





28. Remove the two rubber bushings from the shift rod. Set them aside, they will be reused.



29. The factory shift rod has to be removed and replaced with the new supplied shift rod.



30. The best way to do this is to grind off the end with the smaller diameter head. Once the head has been ground off, use a punch and a hammer to remove the pin from the assembly. Discard the pin. A new pin is included in the kit.

Tools: Disc Grinder, Punch, Hammer



31. The photo to the right shows the bolt removed and the two parts separated.



32. Remove the two (2) bushings and the rubber boot from the old shift rod, being careful not to damage them as they will be re-used.

Tools: Punch, Hammer



33. Remove the shifter retaining plate from the bottom of the shifter housing.

Tools: 10mm Socket, Extension, Ratchet

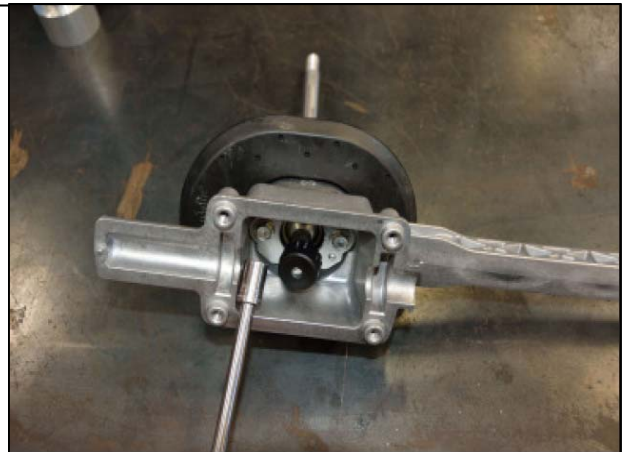

34. Remove the shifter from the housing and disassemble. Use a set of pliers to pry the small pivot cup off of the small pivot ball. The larger pivot cup can be removed by hand. The large pivot cup, the screws and the plate will be re-used.

Tool: Pliers



35. Apply Grease to the factory pivot cup.





36. Apply grease to the new lower stick pivot ball.

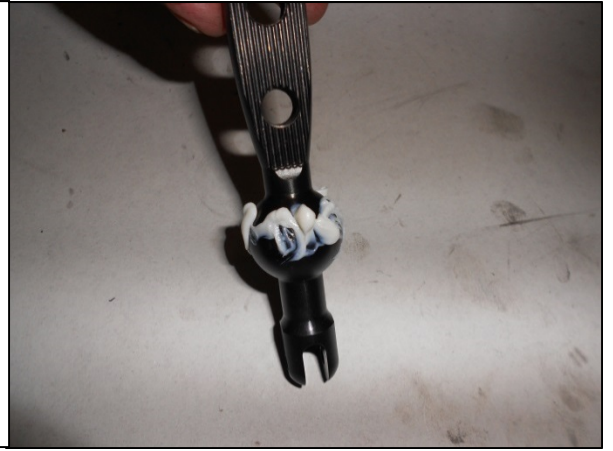

37. Insert the supplied lower stick into the large pivot cup as shown.



38. Install the factory plate.



39. Install the 3/16 sleeve bearing into the swivel link

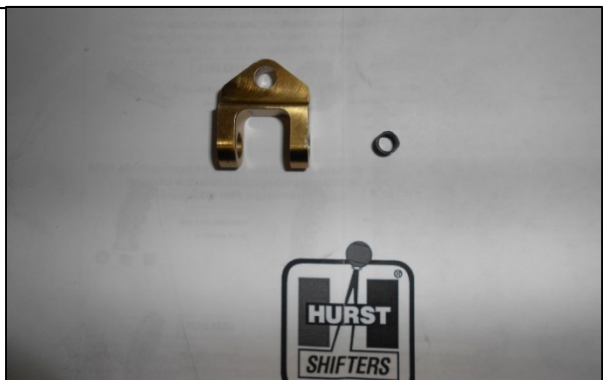

40. An easy way to install this is to add some lube to the sleeve bearing, use a pair of pliers to square up the bearing to the hole on the swivel link and squeeze the bearing down into position.

Tools: Pliers



41. Once the sleeve bearing is flush, scrap any plastic that may have mushroomed over with a razor knife.



42. Add grease to both sides of the swivel and insert the swivel into the stick. Slip a disc spring and a nylon washer onto the shoulder screw. Slide the 3/16" shoulder screw through the stick and the swivel. Secure the parts together with a 8-32 lock nut.

**NOTE:** Add a drop of Loctite to the thread of the shoulder screw prior to install.

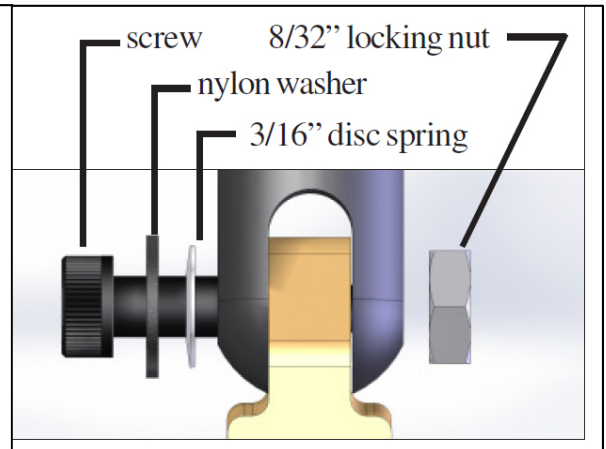

43. Apply grease to flange bushing and insert into swivel, one (1) on each side, as shown in the photo on the right.

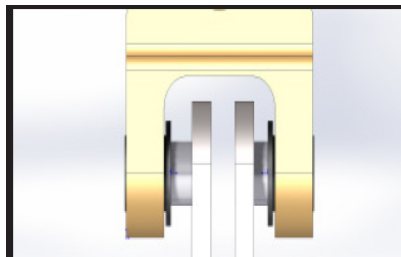



44. Add grease to the links, and then insert a link on each side of the swivel as shown in the photo to the right.



45. This is how it should look after following step 35 through 44.



46. Add grease to flanged bushing. Insert a flanged bushing to each side of the links, to semi-secure the links to the shifter.



47. Add grease to the new shift rod and place it between the links. Ensure that the serrated portion of the shift handle faces the right side of the shift rod as shown.



48. Insert a 1/4" disc spring onto the 1/4" shoulder screw and slide it through one end of the links. Once the screw is through to the other side, add another 1/4" disc spring, and then a #10 washer. Secure it together with a nyloc nut. This is important: You may need to adjust the tension between the nut and screw. You want to be able to rotate the links between the shift rod, but it should be stiff. It should take some effort to rotate. The shifter will not function properly if it is loose.

Tools: 3/32" Allen Wrench, 3/8" Wrench

**NOTE:** add a drop of Loctite to the thread of the shoulder screw prior to install.

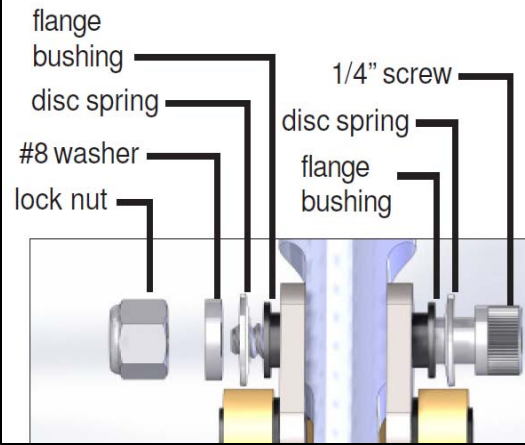

49. Slide on the factory rubber boot



50. Add grease and install the factory linkage bushings into the end of the shift rod



51. Grease the new shift rod.

Install the factory bushings onto the shift rod.



52. Install the lower stick assembly into the shifter housing. Bolt the factory plate back into position.

Tools: 10mm Socket

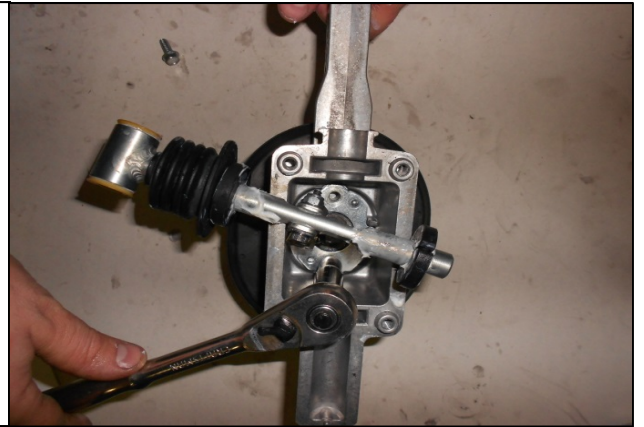

53. Once the factory plate is bolted into position rotate the stick assembly and align the factory rubber bushings into position as shown

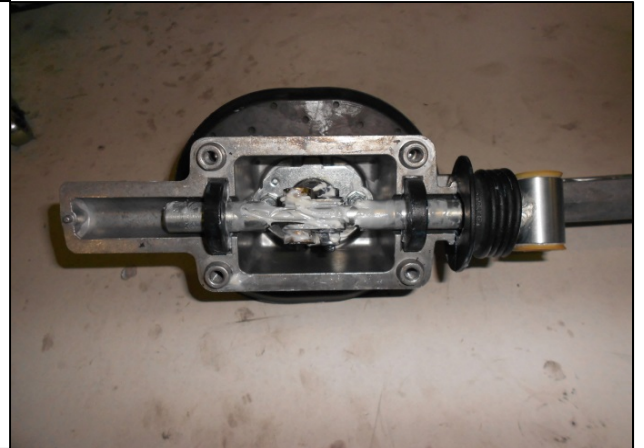

54. Pay careful attention to the orientation of the stick prior to install. The lower stick has two faces. One face is flat while the other face has serrations that will mate with the upper chrome stick, which also has serrations. The face with the serrations should be facing the passenger side once installed.

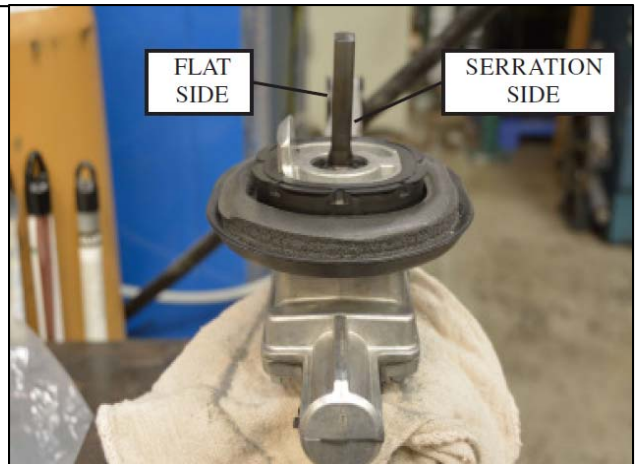

55. Reinstall the bottom plate with the (4) 10mm bolts if the gasket was torn during removal add some RTV in order to proper seal it.

Tools: 10mm Socket, Extension, Ratchet.





56. Insert the end of the shift rod into the shift linkage. Add grease to the pivot bolt and slide it through the linkage. Apply Loctite to a 1/4-20 bolt and secure it with a washer.

Tools: 3/4" Socket, Ratchet, 7/16" Socket

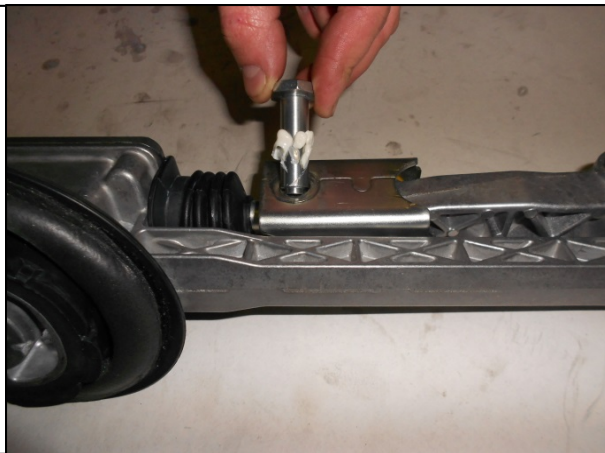

57. Install the new polyurethane bushing supplied with the kit.



58. Insert it into the bracket clip. You will need to form the clip bracket around the new bushing to make it easier to install. The holes need to be 4.21 inches apart to be re-installed. It will be improbable that you will get it to hold at 4.21 inches apart, but try to get it close to 4.21 inches as possible. You will rely on a pair of channel locks to compress the assembly during install.



59. Install the shifter assembly into the vehicle.

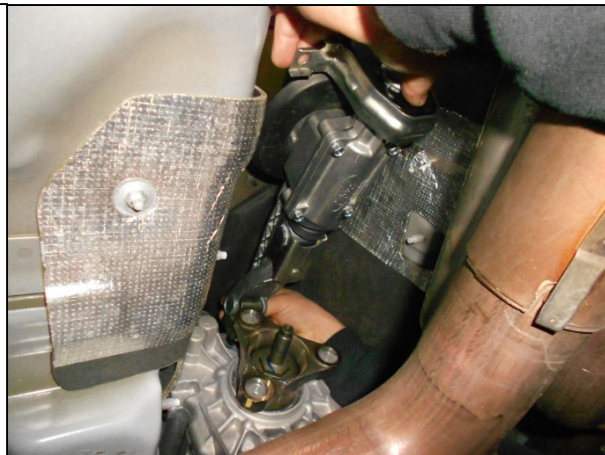

60. Install the shift linkage bolt.

Tools: 13mm Socket, 3/8" Drive Ratchet



61. Install the shifter assembly onto the transmission.

Tools: 10mm Wrench, 10mm Ratcheting Wrench

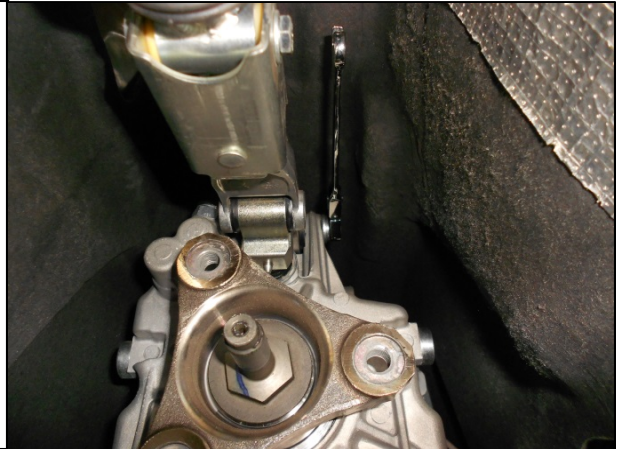

62. You can use a pair of pliers to squeeze the housing in order to align the holes to the studs on the vehicle.

Tools: Pliers, 10mm Socket, Extension, Ratchet



63. Slip the front end of the driveshaft back into the transmission. Align the Driveshaft Flex Coupling to the transmission flange.

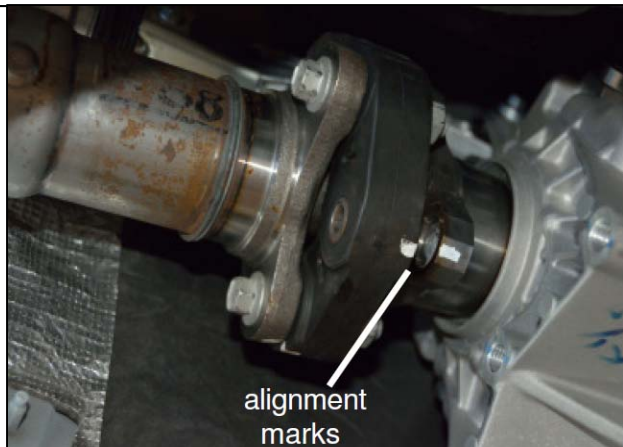



64. Re-install the bearing support. Torque bolts to 35ft.lbs.

Tools: 13mm Socket, Extension, Universal Adapter, Ratchet, Torque Wrench

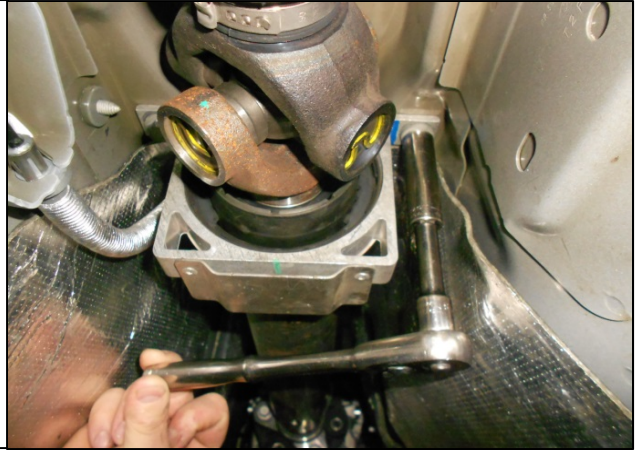

65. Re-install the front end of the driveshaft. Do not forget to align the driveshaft flex coupling to the transmission flange prior to inserting the bolts. Torque bolts to 81ft.lbs

Tools: 18mm Socket, Ratchet, Torque Wrench



66. Re-install the crossmember to the transmission. Torque bolts to 76 ft. lbs.

Tools: 15mm Socket, Ratchet, Torque Wrench



67. Re-install the crossmember to the frame. Torque bolts to 46ft.lbs.

Tools: 18mm Socket, Ratchet, Torque Wrench





68. Reattach the exhaust system

Tools: 15mm Socket

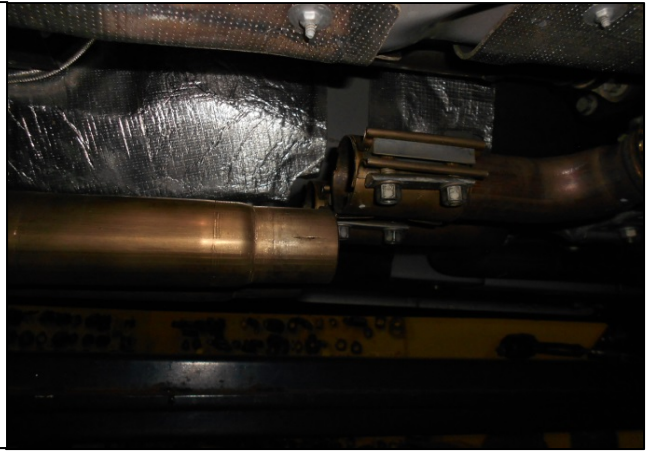

69. Remove the support stand.



70. Lower the vehicle.



71. Install the Upper Chrome Stick and Spring Bracket. The 3/8" guide screw will be inserted and installed into the bottom hole of the stick along with a 3/8" lockwasher and a 3/8" washer.

Tool: 7/32" Allen Wrench

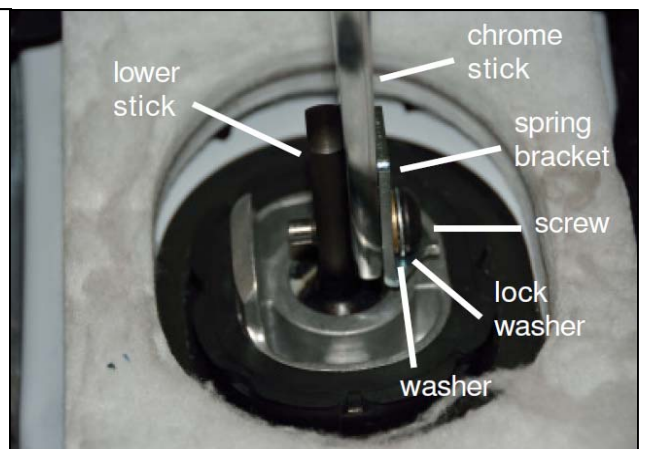

72. Insert the Trigger Rod into the Reverse Lockout Collar.



73. Insert the cotter pin through the hole in the Trigger Rod. Bend each leg of the cotter pin 90 degrees and cut excess material. The photo to the right is a bottom view of the assembly. Please note the orientation of the cotter pin and the approx. length of the legs.

Tools: Needle Nose Pliers, Wire Cutters



74. Align the Trigger Rod so that the top is perpendicular to the opening in the Reverse Lockout Collar. While maintaining the alignment, pull up on the Trigger Rod so that it is at its highest position within the Reverse Lockout Collar and secure it in position with the steel set screw.

**NOTE:** Add a drop of Loctite to threads of set screw to prevent set screw from backing out.

Tool: 5/64" Allen Wrench



75. Thread one of the supplied nylon set screws into the upper hole on the left side of the block. Screw it in until it just begins to protrude into the slotted center opening.



76. Add grease to the inside of the Reverse Lockout Collar. Slip the Reverse Lockout Collar over the sticks. Insert the 3/8" full threaded screw into the top hole of the stick along with a 3/8" lockwasher and tighten screw.

Tool: 7/32" Allen Wrench



77. Install the extension spring to the Reverse Lockout Collar with the supplied Spring Retaining Screw.

Tool: Philips Screwdriver



78. Insert the other end of the spring onto the Spring Bracket tab.

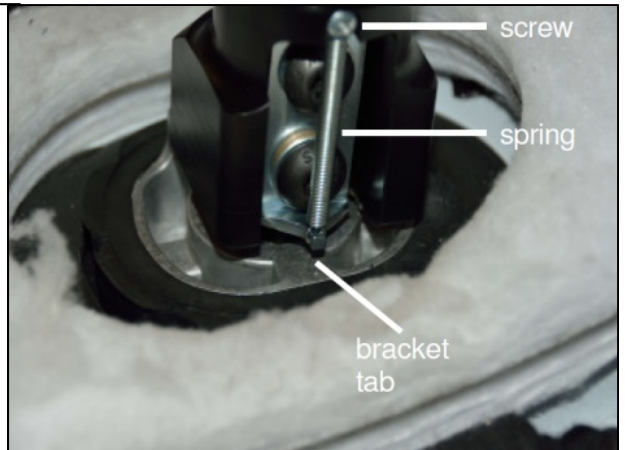

79. Add grease to the Lockout Collar where it rides against the guide nut.

Add a drop of Loctite to the internal threads of the guide nut and install onto the end of the upper screw. Test the Reverse Lockout Collar for proper function. Pull up on the trigger rod and release. The collar should spring back to its lowered position.

Tools: 5/8" Socket, Ratchet

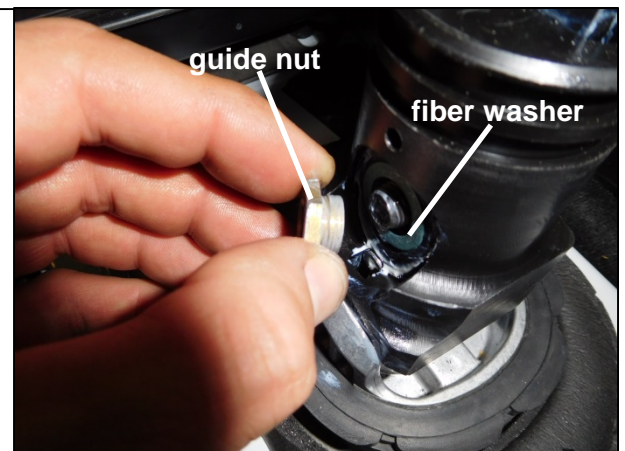



80. Use an allen wrench to adjust the nylon set screw that was installed in step 75. Adjust as necessary to reduce side to side play and get the block to slide up and down freely. Once it's adjusted properly insert a second nylon set screw and tighten against the first to lock in place.



81. To prevent premature wear to the Reverse Lockout Collar, apply grease to the shifter reverse block and lock-out collar where the two will contact during shifts to 1st / 2nd gear.



82. Install the rubber boot over shifter assembly. The top lip should go over the bottom groove of the Reverse Lockout Collar. The bottom lip should seal around the base of the shifter casting.

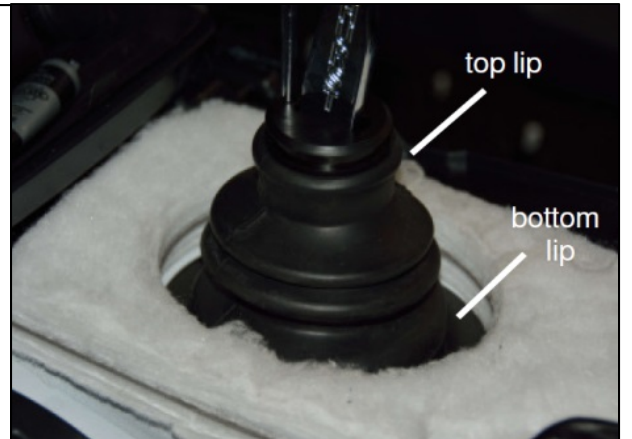

83. Re-install the console.

**NOTE:** Do not forget to re-connect the harness. The vehicle will not start if the harness is not reconnected.

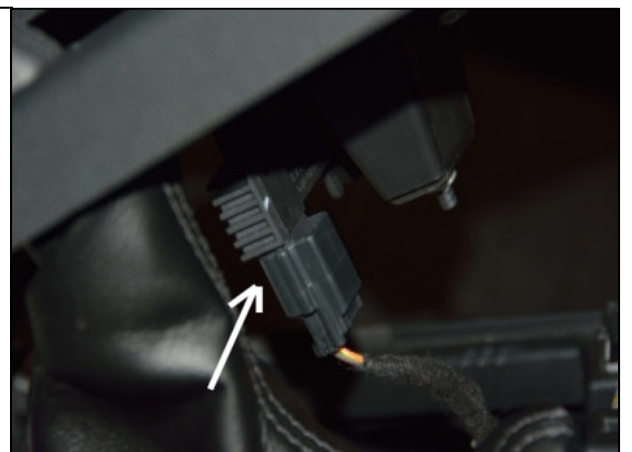

84. The factory shift boot must be modified to fit the Hurst Shifter. The collar must be removed from the boot by carefully trimming the shift boot away from the collar.

Tool: Craft Knife

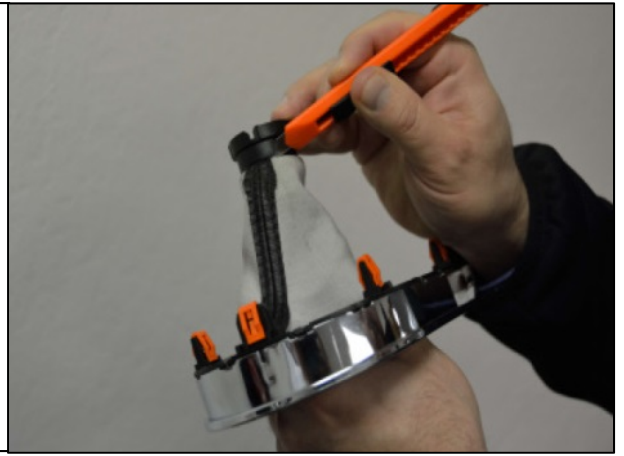

85. Install the shift boot over the shifter and secure the shift boot as shown in the picture to the right with the supplied tie wrap. Cut excess material from tie wrap.

Tool: Side cutters



86. Snap the shift boot bezel into the console.



87. Screw the jam nut down onto the upper stick threads.

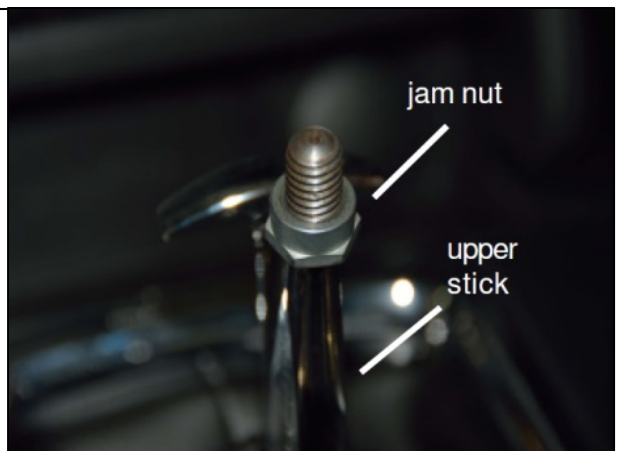

88. Install the shift knob onto the stick. Align the logo on the shift knob accordingly and tighten the jam nut up against the knob. A few drops of Loctite will help prevent the knob from loosening.

**CAUTION!** Over tightening the knob down onto the stick will eventually cause the knob to crack.  
ALLOW LOCTITE TO DRY.

Tool: 9/16" Wrench



89. Re-install the two (2) screws on both sides of the console.

Tool: 7mm Socket, Extension, Ratchet



90. Re-install the front driver side and passenger side panels from the center console.



91. Start the engine. Go through all the gears several times to confirm the shifter has been installed correctly. Ensure that each gear can be engaged smoothly and fully. Correct any problems before operating vehicle. Enjoy!

