



Installation Instructions COMPETITION PLUS STICK KIT

Fits: 1987-1993 Mustang w/Console
Borg Warner T-5 Transmission
Catalog #5380036

WORK SAFELY! For maximum safety, perform this installation on a clean, level surface and with the engine turned off. Place blocks or wedges in front of and behind both rear wheels to prevent movement in either direction.

CAUTION: To avoid any possibility of bodily injury or damage to vehicle, do not attempt installation until you are confident that the vehicle is safely secured and will not move.

FACTORY SHIFTER STICK REMOVAL

1. Apply the emergency brake. Turn the ignition key to the “unlock” and place the shifter stick in the “neutral” position. Remove the shifter knob from the stick.

2. Using both hands, place fingers inside of the console top plate on each side of shifter boot, grasping underneath and pulling up to remove the top plate and the shifter boot from the console.

NOTE: Check the bottom of console top plate, if the factory mounting clips are attached to the tabs on underside of the top plate, carefully remove the clips and set aside.

3. Using a 13mm socket, loosen and remove the two (2) factory mounting bolts located at the bottom of the shifter stick and set aside. These factory mounting bolts will be re-used.

HURST SHIFTER STICK INSTALLATION

1. Place the Hurst Console top plate on a clean flat surface with the logo facing upward. Fold the mounting flange corners of the shifter boot inward and insert through the opening in console top plate. The off- set opening (slot) for the shifter stick must be positioned toward the rear of top plate.

Attach the shifter boot flange onto the mounting pins located on the underside of the top plate and fasten the boot using the four (4) retainer clips supplied. Push the clips completely on the pins to secure the boot.

Install the factory mounting clips (previously removed) onto the tabs located on the underside of the top plate (Refer to Fig.1).

FIG. 1

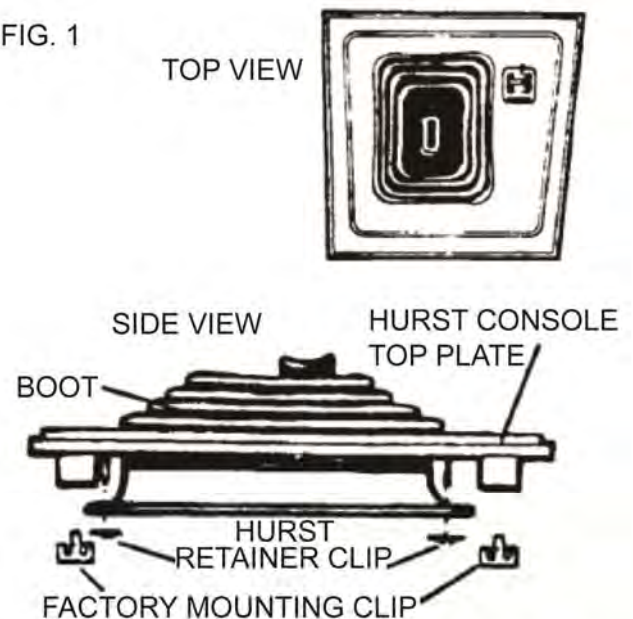

The shifter boot must be installed with the off-set hole (slot) toward the rear of the top plate

2. Place the neoprene isolator between the shifter assembly and the Hurst stick. Fasten the stick to shifter assembly by re-using the two (2) factory mounting bolts. Tighten the bolts securely (See Figure 2).

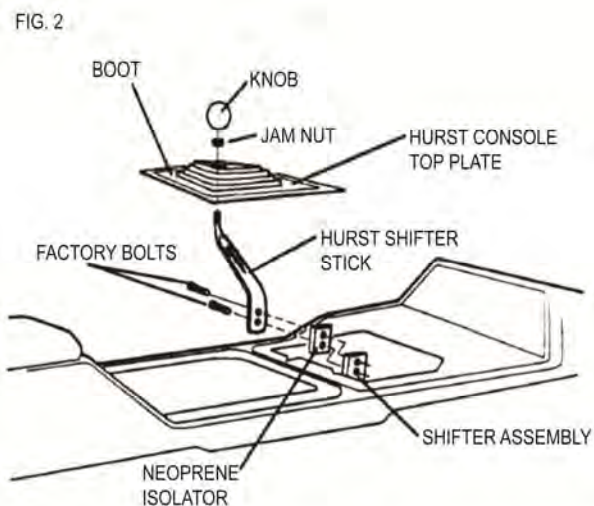

3. Place the console top plate over the shifter and slide the boot down over the stick. Position the top plate onto the console and carefully push down until the top plate is flush with the console and firmly in place.

4. Install the jam nut and knob onto the shifter stick, turn to the desired position and tighten but against the knob.