



Installation Instructions

BILLET/PLUS COMPETITION SHIFTER

1997-2004 Chevrolet Corvette

6 - Speed BWT-56 Manual Transmission

Catalog# 391 5085

© 2015 Hurst Performance

WORK SAFELY! For maximum safety, perform this installation on a clean, level surface and with the engine turned off. Place blocks or wedges in front of and behind both rear wheels to prevent movement in either direction.

CAUTION: To avoid any possibility of bodily injury or damage to vehicle, do not attempt shifter installation until you are confident that the vehicle is safely secured and will not move.

NOTE: This shifter is designed to reduce the throw 40% for shorter shifts, precisely balancing distance, effort, comfort and control to give you the most satisfaction from a shifter. It is constructed of a solid billet steel stick and billet aluminum base, making the feel of the shifter significantly more positive as compared to the stock factory unit. You will also probably notice a slight increase in effort while shifting due to the shorter throw. The shifter accepts the stock factory knob and boot to keep the interior of your vehicle looking original in appearance.

IMPORTANT: Installing the Hurst Billet/Plus Shifter requires moderate mechanical ability. Read this instruction sheet completely so that you thoroughly understand it and can become familiar with the procedure before attempting installation. We highly recommend that you use the appropriate factory service manual along with these instructions for additional procedure details.

FACTORY CONSOLE REMOVAL

Convertible Models Only:

1. Open the convertible top stowage compartment lid. Remove the T15 Torx head screws that attach the top and lower sides of the extension panel. Lift upward on the panel to remove it from the bracket.

All Models:

1. Open the console door. Insert a small flat blade screwdriver into the recess located at the rear of the electronic traction control switch and carefully pry up and out allowing access to the console retaining nuts. Disconnect the electrical connector from the switch. Disconnect the electrical connector from the accessory power outlet.

2. Using a small flat blade screwdriver, remove the plastic lids at the rear of the console to allow access to the retaining nuts. Using a 10 mm wrench or socket, remove the hex nuts that fasten the front and rear of the console to the floor tunnel. Lift the rear of the console to clear the studs and pull rearward to release console from under the instrument panel accessory trim plate.

INSTRUMENT PANEL TRIM PLATE REMOVAL

1. Place the shifter into fourth gear. Using a small flat blade screwdriver at the front edge of the shift pattern indicator, carefully pry out indicator from shifter knob. Using a pair of Vise-Grips, clamp tightly and pull the metal "T" retainer up and out of the knob.

Note: The "T" retainer is usually very difficult to remove. Use care to avoid damaging other components. **Tip:** While pulling upward, rock Vise-Grips from side to side or tap side of Vise-Grips with a hammer. Unscrew knob from shift lever. (See Figure 1)

Figure 1

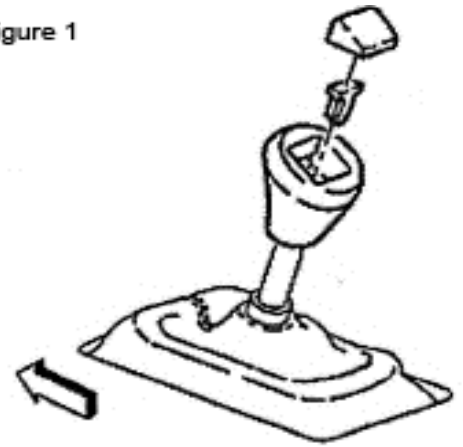

2. Place shifter into neutral position. Grasp the sides of the leather shift boot at the base and gently press inward toward the shifter to release the boot retaining tabs from the trim plate.

Note: Be careful not to break the plastic tabs. Lift the boot up out of the trim plate and over the shifter stick.

3. Open the cigarette lighter door and remove the ashtray. Using a T15 Torx head driver, remove the screws adjacent to the cigarette lighter and behind the ash tray. Carefully pry out the vented insert in the dash next to the ignition switch and remove the remaining Torx head screw.

4. Place shifter into second gear. With the parking brake applied, grasp the instrument panel trim plate near the curve at the base and pull rearward to release the locking tabs. Lift the rear of the trim plate to clear the floor tunnel studs. (See Figure 2)

Figure 2

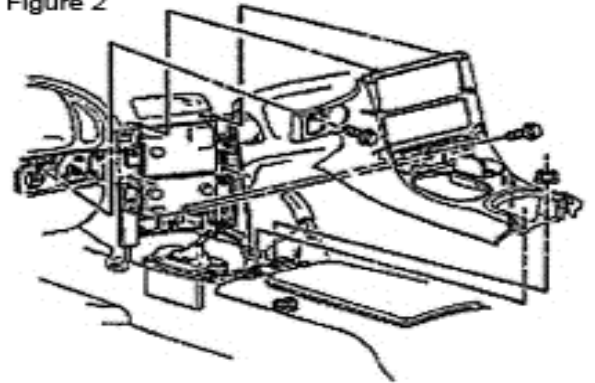

5. Disconnect the electrical plug from the cigarette lighter and lift the trim plate up over the shifter to remove.

FACTORY SHIFTER REMOVAL

1. Remove the four (4) 10mm hex nuts that retain the factory rubber closeout boot. Carefully pry the boot up and off over the shifter. Remove and discard rubber band if present.

2. Place shifter into neutral. Remove the four (4) 3/8" hex head bolts that retain the factory shifter base to the housing and remove shifter assembly by lifting up and out. **Note:** Grasp the alignment pin located on the front of the shifter base and remove while lifting shifter out.

3. Carefully pry off the plastic cup bushing from the end of the factory shifter and set aside for re-installation.

BILLET/PLUS SHIFTER INSTALLATION

1. Remove factory rubber gasket from shifter housing (this will not be reused). Clean mounting surface.

2. Place new mounting gasket (supplied) onto shifter housing.

3. Place the plastic cup bushing that was removed from the factory shifter open end up on a workbench. Put a small amount of grease on the ball end of the Hurst Billet/Plus stick bottom, and place the ball in the open end of the cup bushing. Gently push down on the stick bottom until the ball snaps into the bushing.

4. Install the Hurst Billet/Plus shifter onto the shifter housing making sure that the cup bushing on the stick bottom fits properly into shift selector socket inside the housing.

Important: The shifter must be installed with the notch in the shifter stick threads facing the rear.

5. Install the four (4) socket head screws (supplied) to secure the mounting base to the shifter housing using a 3/16" hex key wrench. Tighten evenly to 8-10 lbs. ft. torque.

Important: Make sure that shifter base is sitting flush onto housing before tightening screws.

6. **Test shifter operation.** Move stick through entire gear shift pattern making sure that it engages each gear fully and that stick moves freely from side to side in "neutral" position.

OPTIONAL ADJUSTMENT OF SHIFTER STOP SCREWS

IMPORTANT! The T-56 transmission contains built-in gear stops. The adjustable stop screws on the shifter are optional and should be removed if not used. These stops are advantageous during gear changes where significant force is used like in racing environments. If the shifter stops are retained, it is very important to adjust the stops exactly as instructed.

7. Adjustment procedure: Remove stop screws and apply thread locker (supplied) liberally to entire thread length. Insert screws until they are flush with the inside of the aluminum base. Pull stick firmly into 2nd gear and hold securely. Turn rear stop screw in until head contacts stick, then back screw out 1/4 turn. Hold screw secure with a 3/16" hex key wrench and tighten jam nut using a 9/16" wrench. Repeat adjustment on forward stop screw. Push stick firmly into 3rd gear and hold securely. Turn front stop screw in until head contacts stick, then back screw out 1/4 turn. Hold screw secure with hex key wrench and tighten jam nut.

OPTIONAL BIAS SPRING ADJUSTMENT/REPLACEMENT

If desired, shifter stick "side to side" tension can be tailored to driver preference and comfort by adjusting or changing the bias springs. Using a 1/4" hex key wrench, turn the hex socket screws on top of the shifter base clockwise to increase tension or counter-clockwise to decrease tension.

Important: Do not turn adjuster screws more than 1 full turn in either direction from the factory preset.

If more or less tension is desired and cannot be achieved by adjusting the screws, there are two (2) sets of additional bias springs supplied with this shifter that can be used to replace the ones installed at the factory. To change the springs, remove the adjustment screws. Each side has an inner and an outer spring, the softer inner and stiffer outer spring are factory installed. You can mix and match combinations of the springs to obtain the desired tension. Clean the threads on the adjuster screws and apply a few drops of thread locker (supplied) to the threads. Reinstall the screws and turn in approximately 3 and 1/2 full turns as a starting point.

Note: Whenever the bias spring screws are adjusted, it is recommended to apply thread locker to the threads to keep screws in place and maintain spring tension.

8. In order for the closeout boot to fit properly around the Billet/Plus shifter base, you must modify the closeout boot in one of the ways listed.

1997-mid '03 models use option A or B

Mid-2003-'04 models use option B only

Option A): Roll the bottom edge of the inner ring of the closeout boot inward and upward, flipping the ring inside out so that it faces upward upon installation.

Option B): Using a sharp utility knife, carefully cut out the inner portion of the factory closeout boot around the inner edge of the raised rib to match the diameter of the Hurst shifter base. Re-install the factory closeout boot and replace the four (4) 10mm hex nuts previously removed. Tighten securely.

9. Place shifter into second gear. Place the instrument panel trim plate over the Hurst Billet/Plus shifter and under the parking brake lever. Re-connect the electrical plug to the cigarette lighter.

10. Align the trim plate locking tabs to their respective slots in the instrument panel and carefully begin pushing the tabs into the slots at the top while positioning the rear of the trim plate onto the floor tunnel studs.

Note: Make sure console is rearward enough to install the trim plate.

Replace the three (3) Torx head screws previously removed. Replace the ashtray and vented insert in the dash next to the ignition switch.

11. Slip the factory leather shift boot over the shifter and align with the opening of the instrument panel trim plate. Press in and around the base of the boot to engage the retaining tabs.

12. Carefully lift and re-install the console onto the floor tunnel studs making sure that the front of the console is positioned under the rear of the instrument panel trim plate. Make sure the rear corners of the console are overlapping the side carpeting, and that the console is seated in its proper position. Replace the front and rear hex nuts previously removed and tighten securely.

Caution: Do not over tighten as this can cause console to crack.

Replace the plastic covers that conceal the hex nuts at the rear of the console.

13. Re-connect the electrical connector to the accessory power outlet, and the electrical connector to the traction control switch inside console compartment. Place the switch into position and push down to secure the retaining clips.

Convertible models only:

Re-install the extension panel for the convertible top stowage compartment. Replace screws previously removed and tighten securely.

14. Replace shifter knob and insert metal "T" retainer back into the slot. Tap down on key until shift knob is tight. If shift knob does not tighten completely, remove the key and flatten its front face slightly using a hammer on a flat surface. Push shift pattern indicator back into knob.

NOTE: Shifter stick is threaded to accept any knob having 9/16"-18 thread.

OPTIONAL DIRECT FIT HURST "CLASSIC" KNOBS

The traditional Hurst Classic Shift Knob is available to fit your new Hurst Billet/Plus Shifter and compliment the interior of your Corvette. These quality crafted knobs measure 2-1/4" in diameter and are available in solid white with engraved black Hurst name and 6-speed pattern, or solid black with engraved white Hurst name and 6-speed pattern. Features a 9/16-18 threaded brass insert and supplied with a jam nut.



White with 6-Speed pattern163 0056



Black with 6-Speed pattern 163 0156

IMPORTANT: RETAIN THESE INSTRUCTIONS FOR FUTURE REFERENCE

Technical Service

A highly trained technical service department is maintained by Hurst Performance to answer your technical questions, provide additional product information and offer various recommendations.

Hurst offers a wide variety of custom T-Handles and knobs that can be used with this shifter to allow the driver to tailor the vehicle to his/hers personal liking. See your local retailer of Hurst products for specific prices.