



Installation Instructions BILLET/PLUS COMPETITION SHIFTER

1993-2002 Camaro / Firebird V8
Borg Warner T-56 6-Speed Manual Transmission
Catalog# 3915060

WORK SAFELY! For maximum safety, perform this installation on a clean, level surface and with the engine turned off. Place blocks or wedges in front of and behind both rear wheels to prevent movement in either direction.

CAUTION: To avoid any possibility of bodily injury or damage to vehicle, do not attempt shifter installation until you are confident that the vehicle is safely secured and will not move.

NOTE: In some cases the factory console will have to be removed in order to install the Hurst Billet/Plus shifter. Due to differences in design and model year changes, we recommend that you refer to a factory service manual for your specific model year to determine the proper procedure for console removal.

FACTORY SHIFTER REMOVAL

1. Disconnect the negative (-) battery cable.

CAUTION: When removing or connecting the battery terminal, use care to avoid intermittent contact (arcing) between the battery post and terminal end. This generates voltages spikes that can damage sensitive ECM (Electronic Control Module) components or memory circuits.

2. Place the shifter into the neutral position.

3. Remove the shifter knob from the stick by turning it counter-clockwise.

4. Remove the console shifter boot by pushing rear of boot forward until plastic tabs clear the console. Lift boot up in rear and pull back (rearward) to disengage front mounting tabs from console and set aside.

5. To remove the upper console, open the compartment lid and locate the mounting tabs in front.

NOTE: Some model years use screws to fasten the tabs, be sure to remove the screws. To release the tabs, push the console forward and lift off. (See Figure 1)

FACTORY CONSOLE REMOVAL

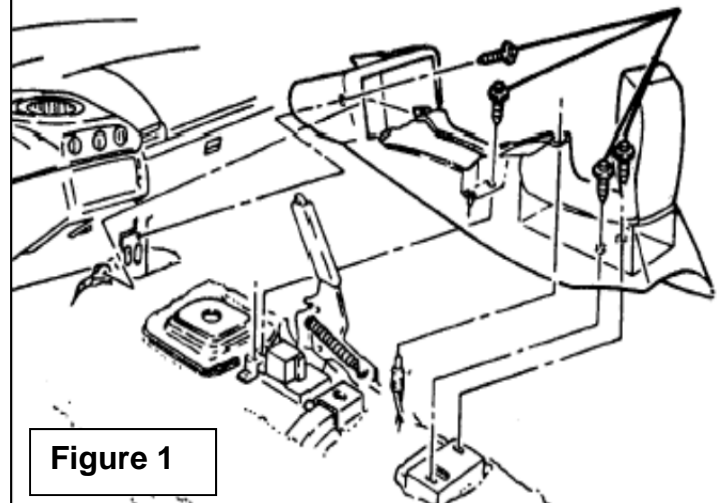

6. Raise the console at the rear and disconnect the electrical wire socket located on the console. Pull the console towards the rear of the vehicle to release the front mounting tabs. Lay the console on its side and remove the ash tray light socket.
7. Using a 13mm wrench, remove the two hex head bolts that attach the shifter stick to the shifter mechanism.
8. To remove the lower console, adjust both seats to the rear of the vehicle and fully recline backward. Parking brake handle must be in a vertical position for removal. To do so, insert a long screwdriver along the passenger side of the parking brake handle, depress the ratchet pawl and pull back on handle until it is vertical.
9. Remove the insert from the console by pulling up to release the Velcro fastener. Using a 10 mm socket, remove the four console mounting screws.
10. Unplug the wiring attached to the cigarette lighter socket and check for any other wiring attached to console.
11. Lift lower console up in the rear and pull back slightly to disengage the front mounting tab. Pull the assembly up over the parking brake handle and remove it from the vehicle.
12. Using a 7 mm socket, remove the mounting screws that attach the lower shifter boot to the floor tunnel, remove the boot and set it aside.
13. Using a 13 mm socket, remove the four hex head bolts that fasten the stock shifter assembly to the transmission. Discard the bolts; new ones are supplied. Lift the shifter assembly straight up and off. (**Note:** you may have some difficulty in removing the stock shifter from the transmission due to the adhesive sealant at the factory.)
14. Remove and inspect the plastic cup bushing. Replace it if it's worn or damaged (This part available from GM part sources). Reinstall the bushing in the transmission.

BILLET/PLUS SHIFTER INSTALLATION

1. Clean the shifter mounting surface on the transmission and apply RTV or similar sealant provided between the Billet/Plus shifter mounting base and the transmission.

2. Install the Billet/Plus Shifter assembly onto the transmission, making sure that the ball on the stick bottom fits properly into the plastic cup bushing. (See Figure 2)

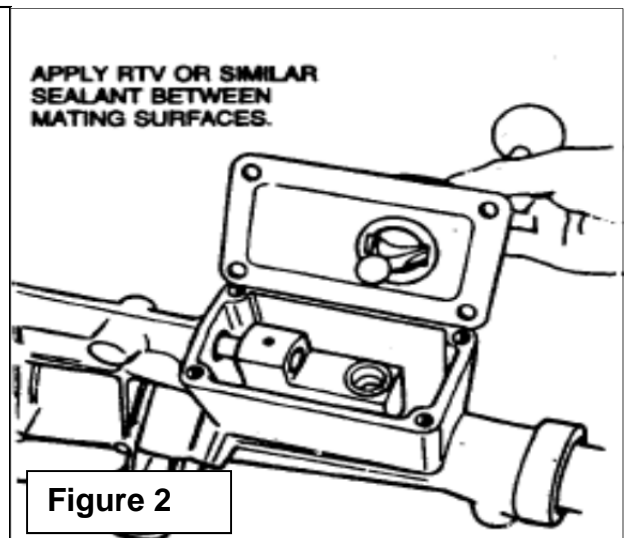

3. Fasten the Billet/Plus Shifter to the transmission using the new hex head bolts and flatwashers supplied. **DO NOT USE THE ORIGINAL BOLTS.** Tighten the bolts evenly. Do not exceed 35ft/lbs. torque. (See Figure 3)

4. Test shifter operation. Move the stick through the entire gear shift pattern, making sure it engages each gear fully and that the stick moves freely from side to side in the “neutral” position.

NOTE: While engine is not running, “reverse” engagement will be difficult due to factory installed “reverse lockout” in transmission.

IMPORTANT
IF STICK IS REMOVED FROM SHIFTER ASSEMBLY DURING INSTALLATION BE SURE TO ENGAGE SERRATIONS AND TIGHTEN BOTH BOLTS EVENLY TO 30-35 FT LBS. THE BOLTS THAT ORIGINALLY FASTENED STICK MUST BE USED.

Figure 3

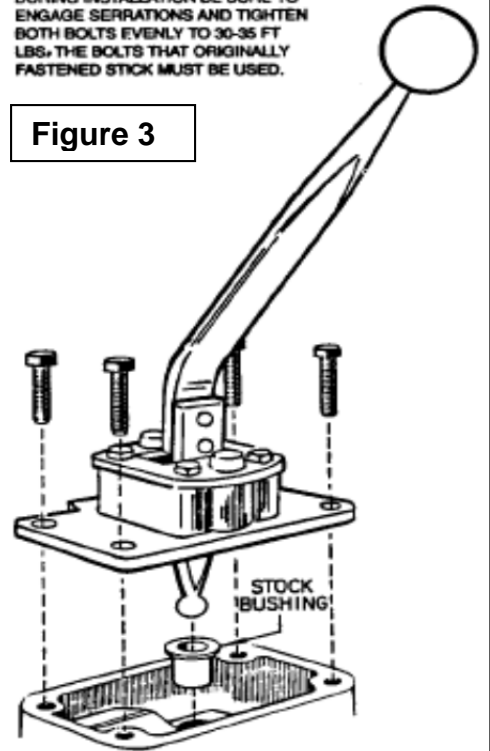

OPTIONAL ADJUSTMENT OF SHIFTER STICK TENSION

Shifter operation can be made “softer” by removing the small spring (inner) from left side of shifter stick or removing both springs. By removing left spring, 2-3 shift will be tighter while 5-6 shift will be softer.

CAUTION: SUDDEN RELEASE OF SPRINGS THAT ARE UNDER COMPRESSION IS DANGEROUS. RELEASE SPRINGS CAREFULLY. REMOVE THE SPRINGS ONE SIDE AT A TIME. SHIFTER CAN BECOME DISASSEMBLED IF BOTH SIDES ARE REMOVED AT THE SAME TIME.

Loosen and carefully remove both socket head cap screws. Remove the slide retainer plate to expose the springs. Remove the inner (smaller) spring only. Replace the retainer and the screws. Tighten both screws to 125-150 inch pounds. Repeat this procedure on the opposite side if desired. (See Figure 4)

NOTE: If you are not satisfied with the “softer” shifter stick tension, reinstall the inner springs.

Figure 4

OPTIONAL REMOVAL OF SMALLER INNER SPRING FOR “SOFTER” STICK MOVEMENT

CAUTION
SUDDEN RELEASE OF SPRING THAT ARE UNDER COMPRESSION IS DANGEROUS! RELEASE SPRINGS CAREFULLY. WEAR EYE PROTECTION.

REMOVE FOUR (4) BOLTS FROM RETAINER. LIFT RETAINER TO EXPOSE SPRING. REMOVE INNER (SMALLER) SPRING. REPLACE RETAINER AND TIGHTEN BOLTS SECURELY.

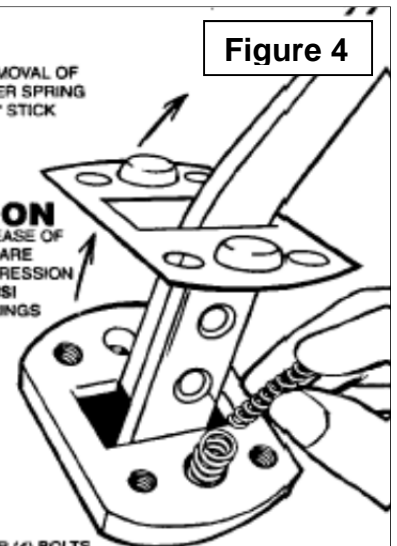

5. Remove stick from shifter assembly. Slide the lower shifter boot over shifter mechanism, leaving mounting holes exposed for stick. Reinstall the factory lower boot mounting screws and tighten securely.
6. Reinstall lower and upper console in vehicle and re-connect electrical wiring. Secure console re-using factory mounting screws.
7. Remove knob from shifter stick, re-install stick to shifter mechanism (be sure to engage serrations) and tighten securely.
8. Lowering the parking brake handle will re-engage ratchet pawl.
9. Reinstall factory shifter boot on console. Install knob onto shifter stick, turn to desired position and tighten jam nut against knob. Reconnect the negative (-) battery cable.