



## Installation Instructions Quarter Stick Shifter

Fits: GM Powerglide w/forward or reverse valve body. Also fits: TH250, TH350, TH375 and TH400 Auto transmissions w/reverse valve body.  
Catalog# 3162020

---

**WORK SAFELY!** For maximum safety, perform this installation on a clean, level surface and with the engine turned off. Place blocks or wedges in front of and behind both rear wheels to prevent movement in either direction.

**CAUTION:** To avoid any possibility of bodily injury or damage to vehicle, do not attempt installation until you are confident that the vehicle is safely secured and will not move.

### **WARNING! THIS SHIFTER IS FOR RACING USE ONLY. NOT FOR STREET USE!**

All adjustments must be made with the shifter and transmission in Neutral (N). Adjustments are critical and must be precise. Do not mix components (all parts including cable must be Hurst components provided with kit). If a shifter is removed and reinstalled, adjustments must be checked and re-adjusted. Always check cable for freedom of motion before connecting at shifter and transmission arm. Routing of cable should avoid sharp bends (permanent damage of cable will result).

**Failure to comply with any of the above may result in malfunction of shifter operation. Damage to the cable due to sharp bending or kinking is NOT covered by warranty.**

Quarter stick shifters are set up for 2 speed (Powerglide) or 3 speed (Turbo-Hydromatic). The shifter can be changed to either mode by removing the revers lock-out retainer plate and exchanging either the block adapter for the spacer, or the spacer for the block adapter. See Illustration on Page 8.

The shifter can be mounted directly to the floor with the four sheet metal screws supplied. If shifter is mounted directly to the floor, the four supplied spacers are to be secured to the inside of the aluminum cover with epoxy adhesive. See section view on Page 8.

Specifications for making a "quick release plate" are found on page 7 of this instructions sheet. The plate is to be made from 1/8" thick aluminum or steel, and allows the shifter to be installed and removed by simply inserting and withdrawing the quick release pins.

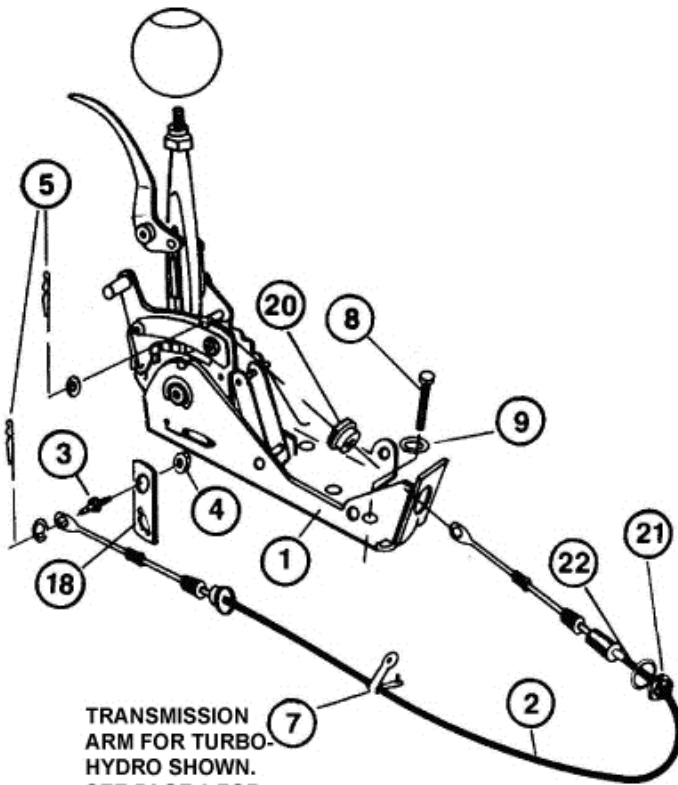

TRANSMISSION  
ARM FOR TURBO-  
HYDRO SHOWN.  
SEE PAGE 3 FOR  
DRAWING OF  
POWERGLIDE  
APPLICATION

### CONTENTS OF KIT

1. Kit Shifter
2. Cable
3. Cable Attachment Pin
4. Hex-Nut
5. Cotter Pin
6. Cable Attachment Clip
7. Cable Support Clamp
8. 1/4" x 1" Self-Tapping Hex-Head Sheet Metal Screw
9. 1/4" Flatwasher
10. 15/16-18 x 1 Hex Head Cap Screw
11. Spacer - \*See Note Below
12. Adapter Block - \*See Note Below
13. 5/16" Flatwasher
14. Spacer-Cable Bracket

### **POWERGLIDE APPLICATION ONLY (2 speed)**

15. Bracket – Transmission Cable
16. Arm & Shaft Assembly (Transmission)

### **TURBO-HYDROMATIC APPLICATION ONLY (3 speed)**

17. Bracket – Transmission Cable
18. Arm (Transmission)
19. Spacer – (Optional – Use When Shifter is Fastened Directly to the Floor)

### **Bagged Hardware**

20. Bezel Nut
21. Hex Nut
22. Flatwasher

\*Adapter Block is installed in shifter for Powerglide Application. Spacer is installed in the Shifter for Turbo-Hydromatic Application

Carefully direct threaded end of cable through shifter frame toward cable stud as shown in exploded view. Secure threaded portion of cable housing to shifter frame as shown using provided bezel nut, hex nut and flatwasher. Center thread so that an equal amount is visible on each end after the nuts are finger tightened.

Temporarily slide the end of cable onto the stud to insure proper routing through the shifter. See Figure on Page 4. Shift to Neutral, then slide the cable off of the pin.

Remove the stock transmission arm. Assemble the cable pin in the Hurst arm with the hex nut as shown. Install the arm on the transmission control shaft. Then, install the cable bracket onto the transmission. Refer to directions with the illustration of your installation. Carefully route the cable toward the transmission cable mounting bracket and fasten in place with the cable attachment clip. Push the clip in until it is seated against the ferrule on the cable and front face of transmission cable mounting bracket.

**CAUTION!** Avoid sharp bending of cable. Cable will be permanently damaged by any sharp bending.

Locate cable hanger to apply support where it is most needed. Drill a ¼" diameter hole through floor for cable hanger. Fold the clamp around the cable and push pointed end through the split end. Apply force until the joint snaps together. Rotate transmission arm to Neutral and secure moveable end of cable to pin with flatwasher and cotter pin.

At shifter, note position of moveable spade end of cable relative to cable stud (See Page 4). Shifter should be in Neutral. Using the retaining nuts at threaded portion of cable, adjust the cable until the spade end will freely enter on to cable stud. Shift through each gear position (up & down) and check for free entry of cable end on the stud in each gear position. Re-adjust if necessary to insure proper function. When satisfied with adjustment, tighten retaining nuts on threaded portion of cable without disturbing previous adjustment. Install cotter pin on the stud and secure.

**NOTE:** If adjustment feature of cable is installed at transmission end, the same procedure for adjustment must be used, while a helper is shifting the Quarter Stick.

### SHIFTING PATTERNS

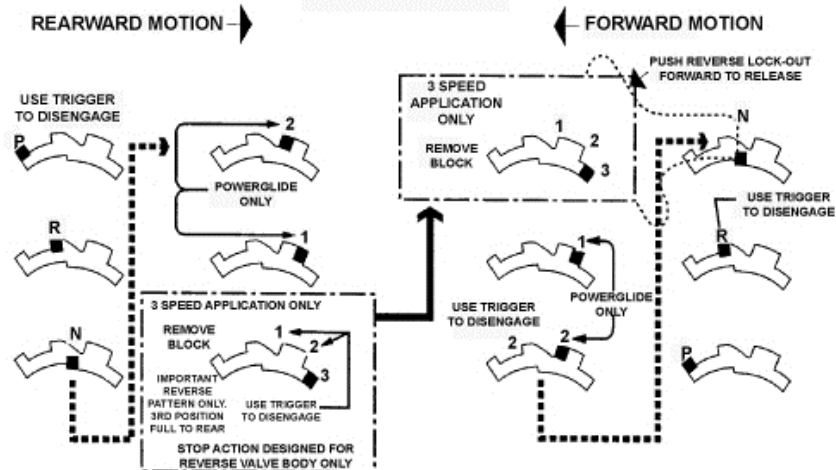

### 3 SPEED APPLICATIONS

#### 200, 350 and 400 TURBO HYDRAMATIC

To mount the cable bracket for the 200 and 350 Turbo Hydramatic you must use the round holes in the bracket. To mount the cable bracket for the 400 Turbo Hydramatic you must use the slotted holes.

When installing the cable bracket on the 200, 350 and 400 Turbo Hydramatic transmissions, spacers and washers will need to be used to provide necessary clearance between the bracket and the transmission pan. Place a 5/16-18 x 1 washer H.H.C.S. Then insert the bolt through the holes in the bracket and place the spacer on the bolt. If needed, 2 washers are supplied for proper clearance.

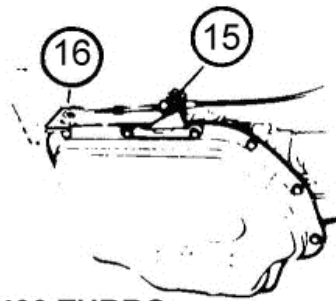

**400 TURBO  
HYDRAMATIC**

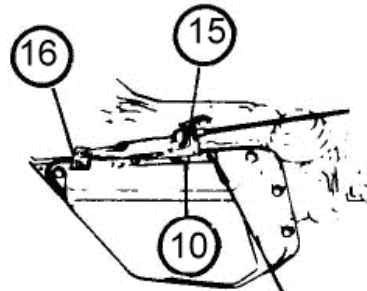

**350 TURBO  
HYDRAMATIC**

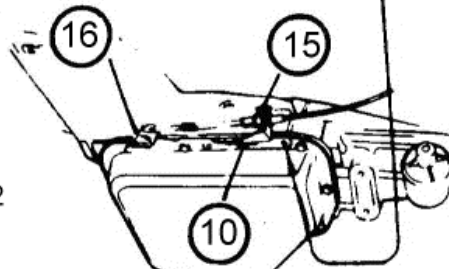

**200 TURBO  
HYDRAMATIC**

#### ALIGNMENT PROCEDURE

1. Position shifter stick at "N" (Neutral).
2. Position transmission arm at "N" (Neutral)
3. Adjust cable as directed on Page 3.
4. Fasten cable end on pin with flatwasher and cotter pin.

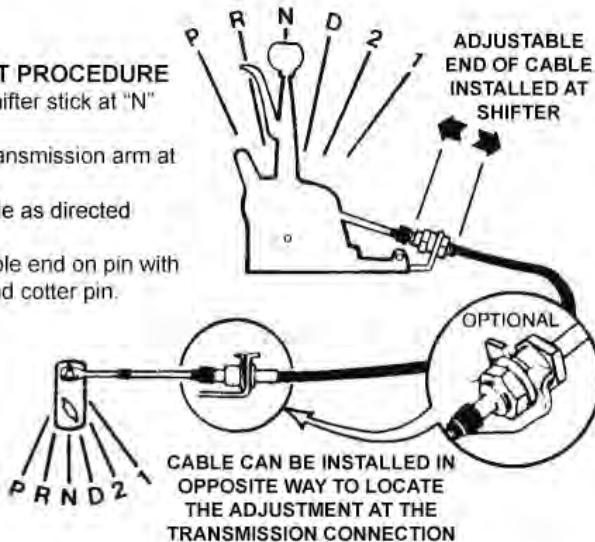

#### ATTACH CABLE END TO PIN ON SHIFTER STICK

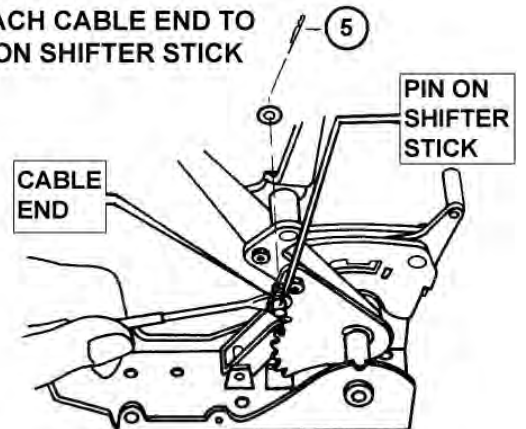

**WARNING!** Installation of Quarter Stick shifter on Powerglide transmission eliminates throttle pressure control linkage (kickdown valve).

Powerglide installation of the Hurst Quarter Stick is for racetrack use only. Under no circumstances is this shifter to be used in a vehicle that is operated on public highways or streets. In no case shall Hurst Performance, Inc. be liable for any direct or consequential damages resulting from improper use of this unit.

Use hacksaw to cut protruding part of transmission away to allow cable racket installation. Clean all metal chips away from the transmission before removing the oil pan. Remove all stock linkage. Drain transmission. Remove oil pan. See Figure 1.

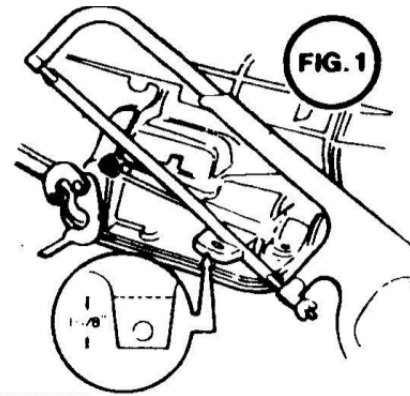

**IMPORTANT: DO NOT ALLOW FOREIGN MATTER (DIRT, METAL CHIPS, ETC.) TO ENTER TRANSMISSION OR CONTAMINATE ANY INTERNAL PARTS. IF NECESSARY, WASH PARTS IN SOLVENT AND BLOW THEM DRY WITH COMPRESSED AIR.**

Remove the two screws that fasten the detent guide plate over the internal end of the control linkage. Remove the guide plate. See Figure 2.

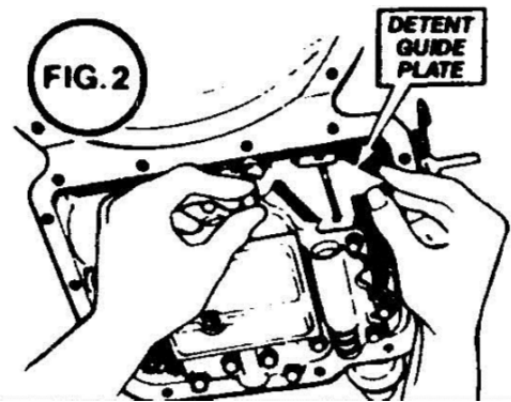

Loosen the screw that fastens the extension spring anchor plate to release tension on the detent roller. See Figure 3.

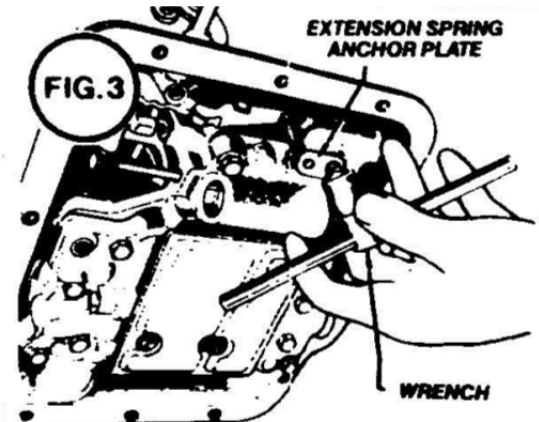

Loosen the socket head cap screw that fastens the throttle pressure actuator (transmissions that have throttle pressure control).

**NOTE:** Installation of the solid control shaft supplied with this kit in the Powerglide transmission eliminates throttle pressure control. See warning on page 5 of instruction sheet.

Grasp the actuator and pull the throttle pressure control shaft out of transmission control shaft. Stock transmission control shaft is now ready for removal.

See Figure 4.

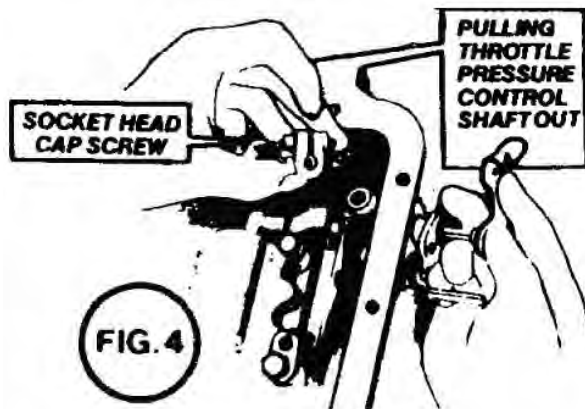

The flat area on the end of the solid control shaft fits within the span of the serrations in the detent plate.

See Figure 5 for full details. Loosen the socket head cap screw that fastens the detent plate to the control shaft. Grasp detent plate carefully to keep it in position as you withdraw the original shaft and replace it with the solid shaft. The detent plate is linked to PARK lock actuator plunger. Take care to keep this assembly in position while exchange of controls shafts is accomplished. You must hold the detent plate in position with one hand while you remove the original shaft and install the solid one. Stud pin in the detent plate must engage the groove in the manual valve. Tighten the socket head cap screw to fasten the detent plate to control shaft. Align the detent roller with detent plate, then tighten the anchor plate screw to restore tension to the extension spring. Replace the detent guide plate. Rotate detent plate through full travel to prove correct assembly.

(P-R-N-D-L)

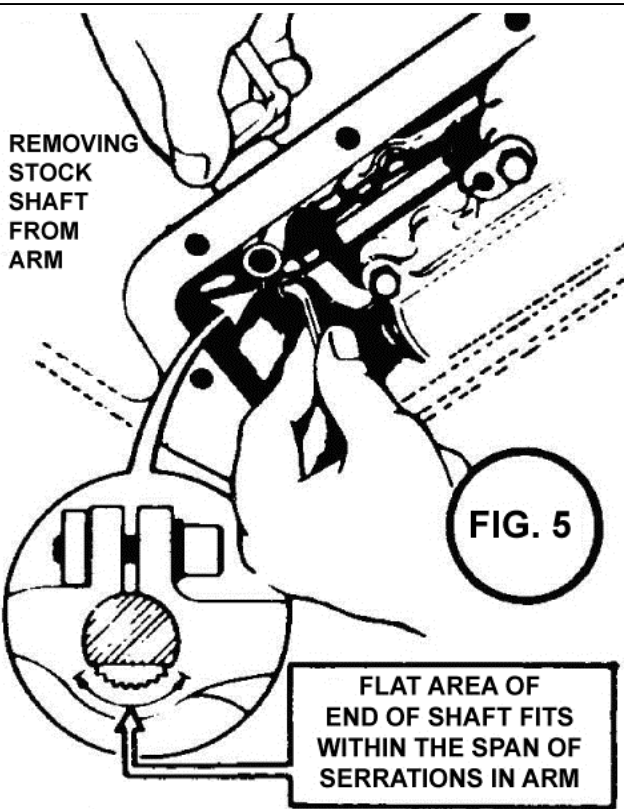

Make cuts with a hacksaw. Break away a small length between cuts as seen in Figure 6. Flatten the lip of the flange between the extreme cuts with a ball peen hammer as shown in photograph. Inspect reworked area of oil pan flange. The gasket mating surface and areas around the bolt holes must be flat. Use a ball peen hammer to peen the flange flat (with pan properly supported on anvil, etc.). Clean the pan thoroughly in solvent. Install oil pan with new gasket. Cable bracket is installed with pan bolts. Tighten all bolts evenly. Install fresh transmission fluid.

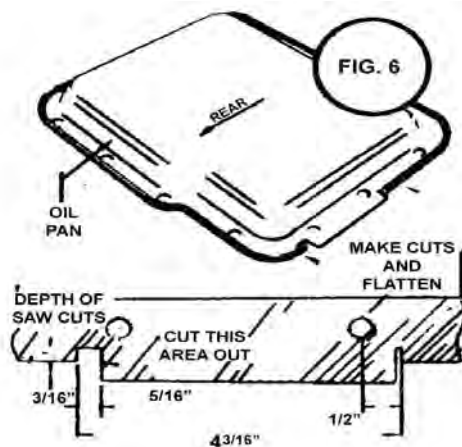

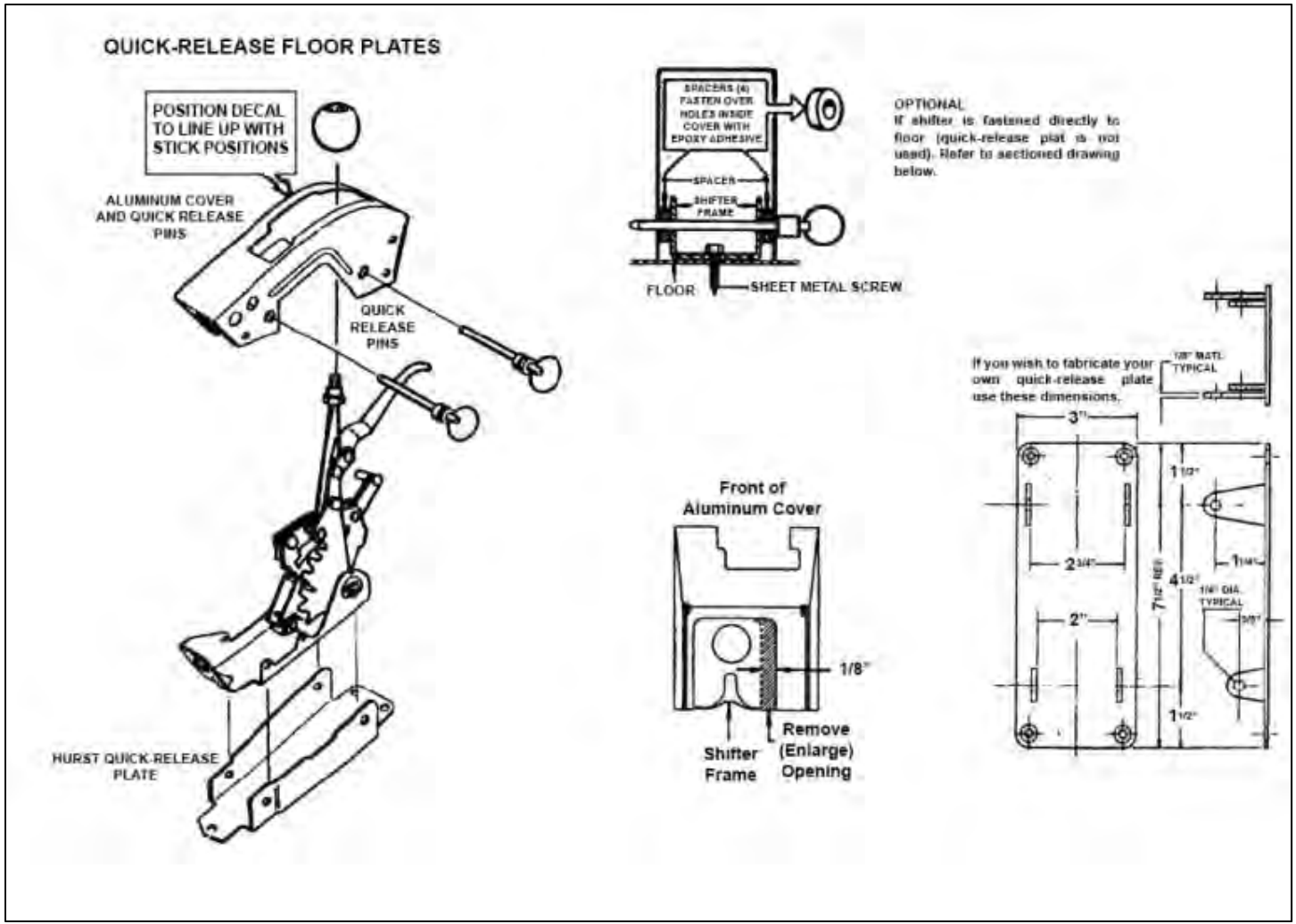
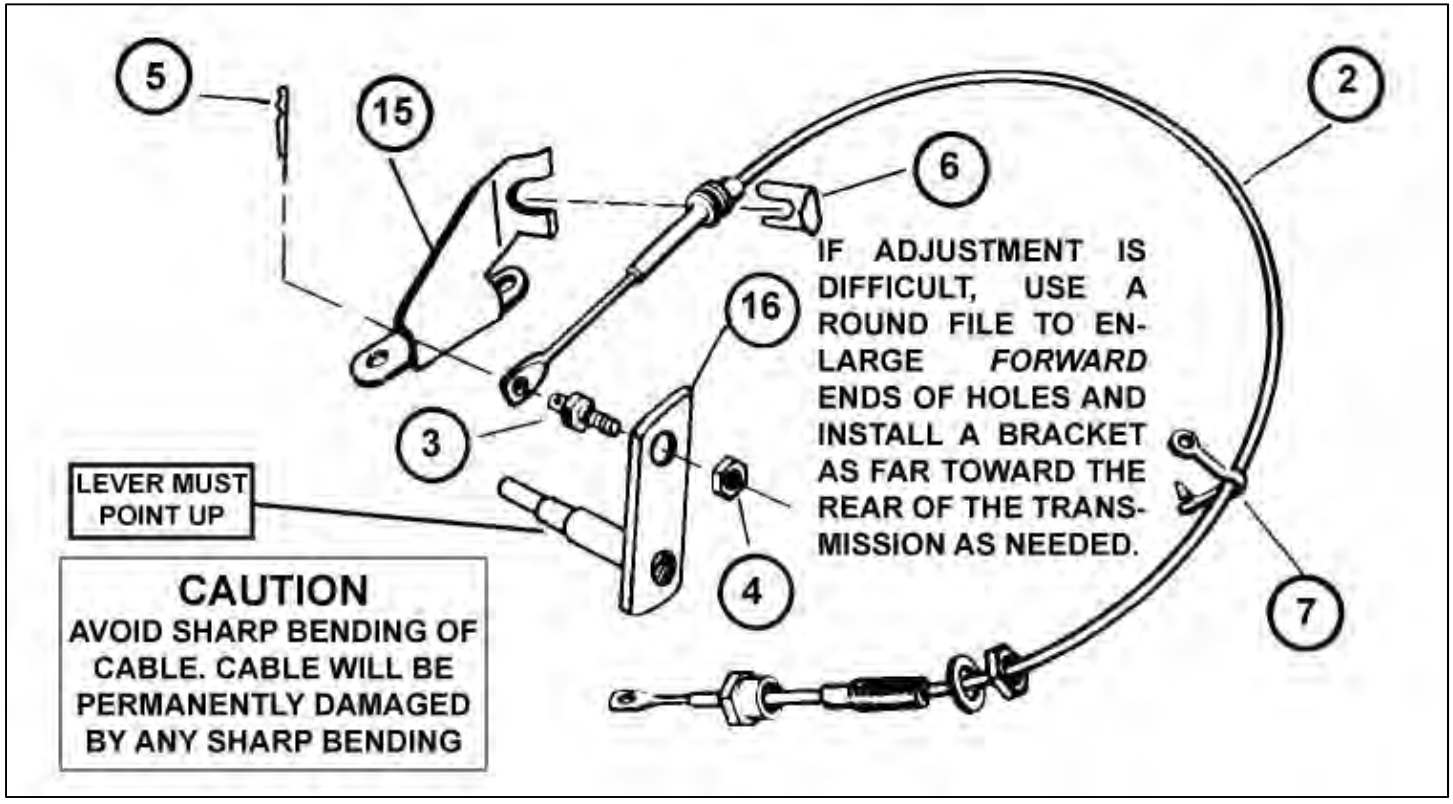

## TO CONVERT FROM 2-SPEED POWER GLIDE TO 3-SPEED TURBO, OR VICE-VERSA.

Quarter Stick Shifters are set up for 2-speed (Powerglide) from the factory, but with the following modification procedure your shifter will be ready to use on a 3-speed (Turbo-Hydromatic).

**NOTE:** Where small shims and Loctite® are used, this is important for free movement of the reverse Lock-out lever.

1. Place the shifter lever all the way forward to PARK position for easy access to socket screw.
2. Insert 3/32" hex key into the flat head socket screw and hold while removing the #8-32 self-locking hex nut with an 11/32" wrench.
3. If necessary, loosen 1/4-28 button head screw with 5/32" hex key to swing retainer plate upward for access to block to adapter.
4. Remove the block adapter, put the flat head socket screw back through the hole and put a small spacer on the screw. There may be a small shim to put in between the spacer and retainer plate.
5. Place the retainer plate back in position. Put a flatwasher and #8-32 self-locking nut on and tighten.
6. If the 1/4-28 button head screw has been loosened, back it out no more than 3 turns and put Loctite® on the threads of the plate. Be extremely careful not to remove this screw completely as there are internal shims that must stay aligned. Retighten, while being sure the reverse lock-out lever must move freely.

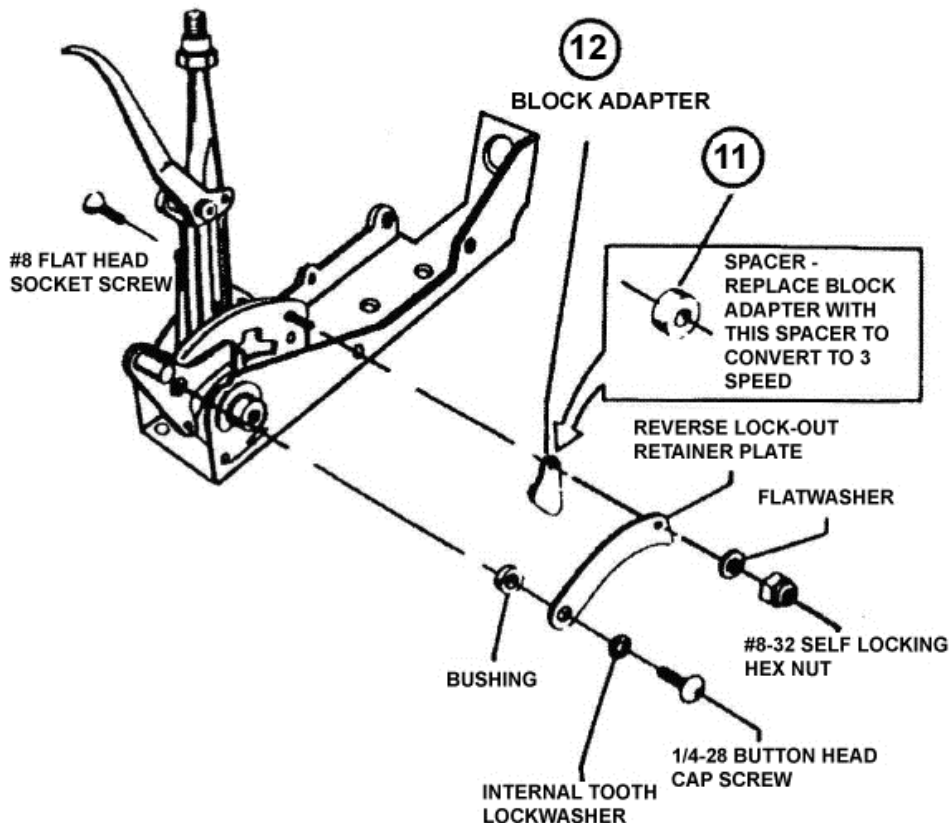



## Neutral / Park Start Safety Switch Electrical Wiring Instructions

1. Install the supplied female crimp terminals to two suitable lengths of wire using at least 16 gauge wire.
2. Plug each female connector onto the spade terminals of the micro switch located in the plastic switch housing.
3. Using the wiring diagram below as a guideline, install the switch wires into your starting circuit.
4. With shifter and transmission in neutral, check to see that the engine starts. Repeat this with the shifter and transmission in the park position. If necessary, loosen the screw on the adjusting collar located near the shifter handle and adjust the slide mechanism back and forth until the vehicle starts in Neutral and Park only.

## Pistol Grip Roll / Control Switch

The Pistol Grip Quarter Stick shifters come equipped with a precision, snap-action, 12 volt switch that is ideal for operating the Hurst Roll/Control, nitrous oxide systems, trans. brakes, etc. It is a normally open, momentary contact, quick release switch with a maximum 10 amp. rating.

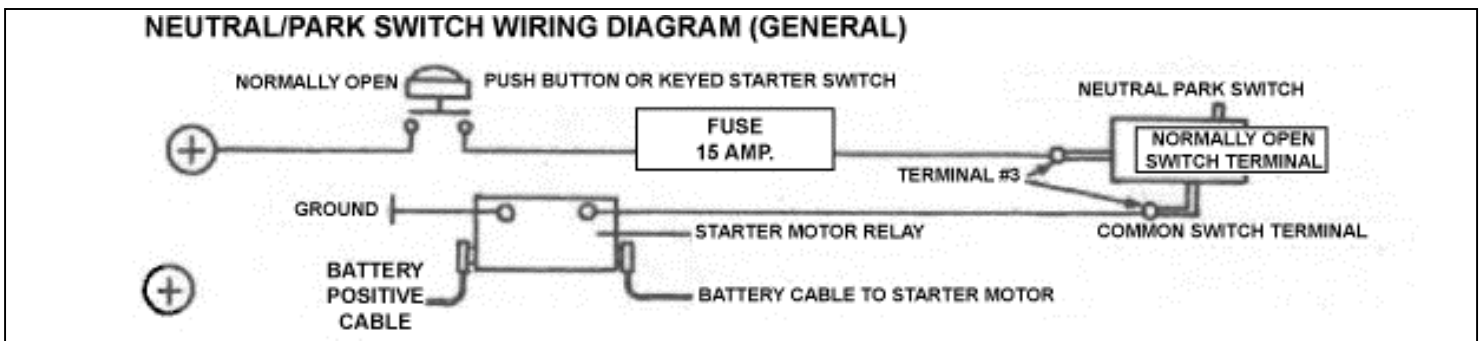

**IMPORTANT: RETAIN THESE INSTRUCTIONS FOR FUTURE REFERENCE**

## Technical Service

A highly trained technical service department is maintained by Hurst Performance to answer your technical questions, provide additional product information and offer various recommendations.