



Installation Instructions

Hurst Solenoid Shifting Kit

Fits: Hurst Quarter Stick® and Pistol Grip Shifters

Catalog # 2260020

WORK SAFELY! For maximum safety, perform this installation on a clean, level surface and with the engine turned off. Place blocks or wedges in front of and behind both rear wheels to prevent movement in either direction.

CAUTION: To avoid any possibility of bodily injury or damage to vehicle, do not attempt installation until you are confident that the vehicle is safely secured and will not move.

This electric solenoid shifting kit is designed to automatically complete the 1st to 2nd gear change on all Hurst Quarter Stick shifters with forward shift patterns. It must be use with a 12-bolt automotive electrical system. This kit may also be adapted to the B&M Pro Stick Shifter and Hurst Quarter Stick 2 (rear exit cable model) with minor bracket modification.

NOTE: For added safety, it is recommended to follow the wiring recommendation properly in order to prevent accidental engagement of your system.

INSTALLATION OF HURST SOLENOID SHIFTING KIT

1. Disconnect the negative (-) battery cable.
2. Remove fasteners from shifter and raise shifter up form floor (cable does not need to be disconnected).
3. Using existing mounting holes, install the solenoid bracket under the shifter, aligning the mounting holes, remount unit into vehicle using existing fasteners. Tighten fasteners securely.
4. Attach the electric solenoid to the mounting bracket using the four spacers and fasten with two ¼"-20 hex head bolts, nuts and ¼" flat washers. Tighten securely. (See Figure 1 on page 3)
5. Place shifter stick into 2nd gear position. While holding the solenoid plunger, turn adjusting nut on the backside of the solenoid to allow 1/16" clearance between plunger and shifter stick.

WIRING

1. All wiring used should be a minimum of 18 gauge automotive grade.
2. Either black wire from the solenoid can be used for 12-volt source and ground.
3. If you are using an RPM-activated switch to control the solenoid, refer to the manufacturer's instructions for proper wiring connections.

4. If you are using a manually-activated switch, it must be a normally “closed” switch that is momentarily “open” when activated. (See Figure 2)

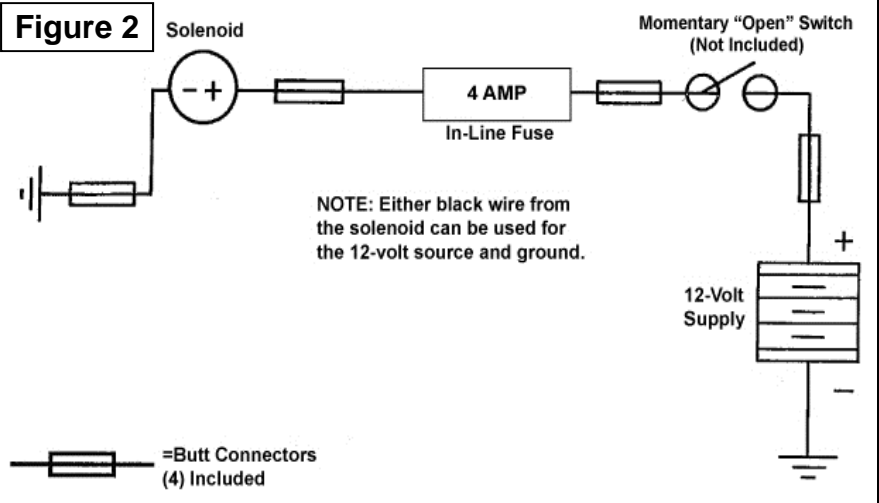

IMPORTANT: The solenoid must be energized for the shifter to remain in 1st gear.

Solenoid Operation

Note: Be sure the negative (-) battery cable has been reconnected.

1. Pull the shifter stick back into 1st gear position pushing the plunger into the solenoid. If you are using an RPM-activated switch, follow the manufacturer’s instruction to activate the solenoid.
2. If you are using a manual-activated switch, at the desired RPM or speed, release or “open” the switch to de-energize the solenoid causing the spring to push the plunger forward. This action will shift the transmission from 1st to 2nd gear.

Solenoid Specifications

12-Volt With Maximum Rated Amp Draw of 3-Amps.

IMPORTANT: RETAIN THESE INSTRUCTIONS FOR FUTURE REFERENCE

Technical Service

A highly trained technical service department is maintained by Hurst Performance to answer your technical questions, provide additional product information and offer various recommendations.

Technical service calls, correspondence, and warranty questions should be directed to:

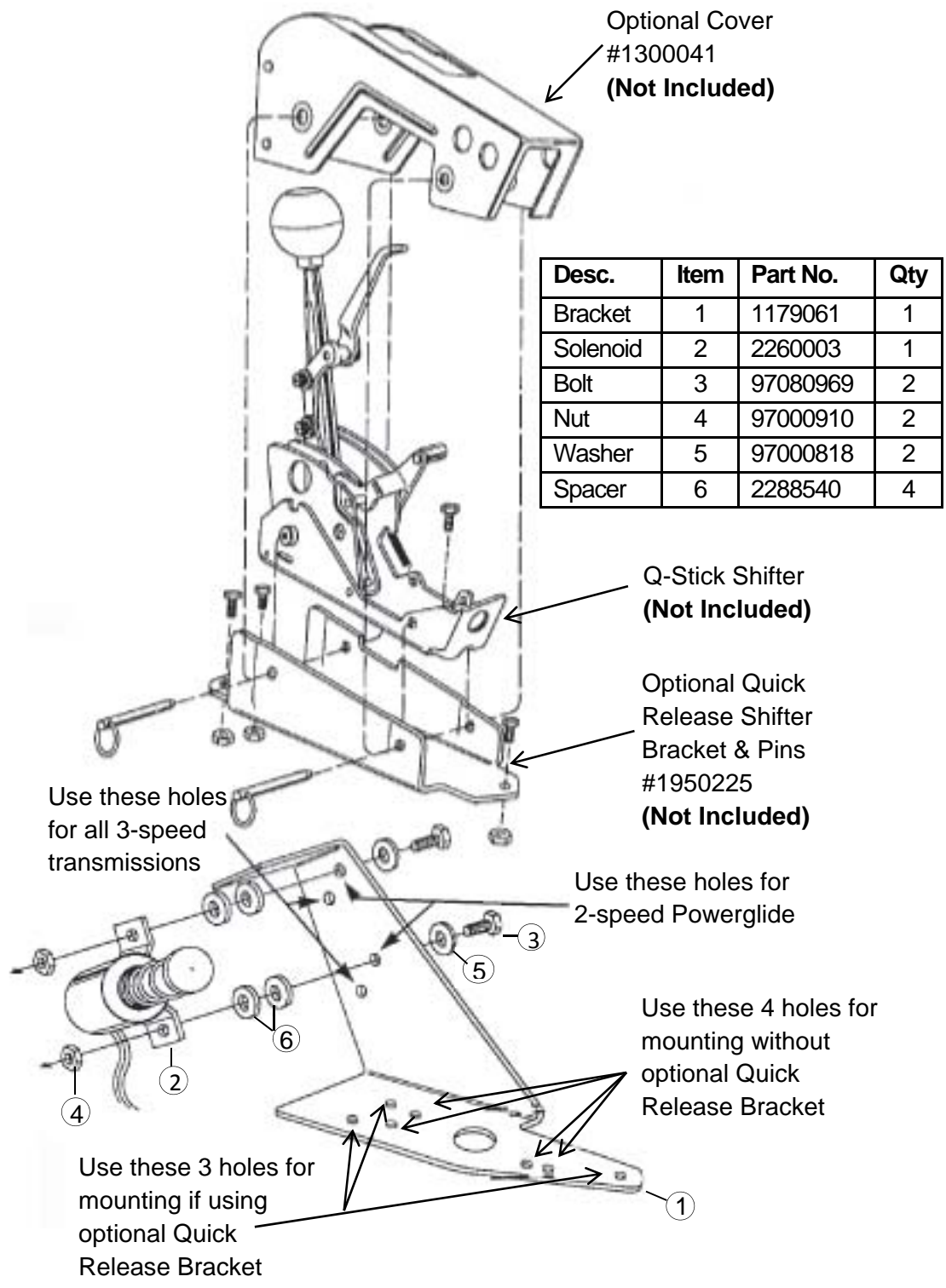

Desc.	Item	Part No.	Qty
Bracket	1	1179061	1
Solenoid	2	2260003	1
Bolt	3	97080969	2
Nut	4	97000910	2
Washer	5	97000818	2
Spacer	6	2288540	4