



Installation Instructions

HURST BRACKET and LEVER KIT

GM 4L60E, 4L65E, 4L80E and 4L85E (with PRNDL switch)

1595498 REV01 08/21/15

Catalog# 1175498
© 2015, 2014 by Hurst Performance

WORK SAFELY! For maximum safety, perform this installation on a clean, level surface and with the engine turned off. Place blocks or wedges in front of and behind both rear wheels to prevent movement in either direction.

CAUTION: To avoid any possibility of bodily injury or damage to vehicle, do not attempt installation until you are confident that the vehicle is safely secured and will not move.

NOTE: This kit is used for the GM 4L60E, 4L65E, 4L80E and 4L85E equipped with a PRNDL switch only.

STEP 1. Raise and safely support the vehicle at least 1-2 feet off the ground. Remove the stock selector lever nut and the selector lever. Discard the stock lever and the stock shifter linkage. Install the **HURST** selector lever in position using the stock selector lever nut (See Figure #1). Torque the nut to 23 lb-ft. The lever should move smoothly from front to rear with a positive stop in each gear position. Remove the two transmission oil pan bolts from the middle of the left side of the oil pan. Install the cable bracket in position

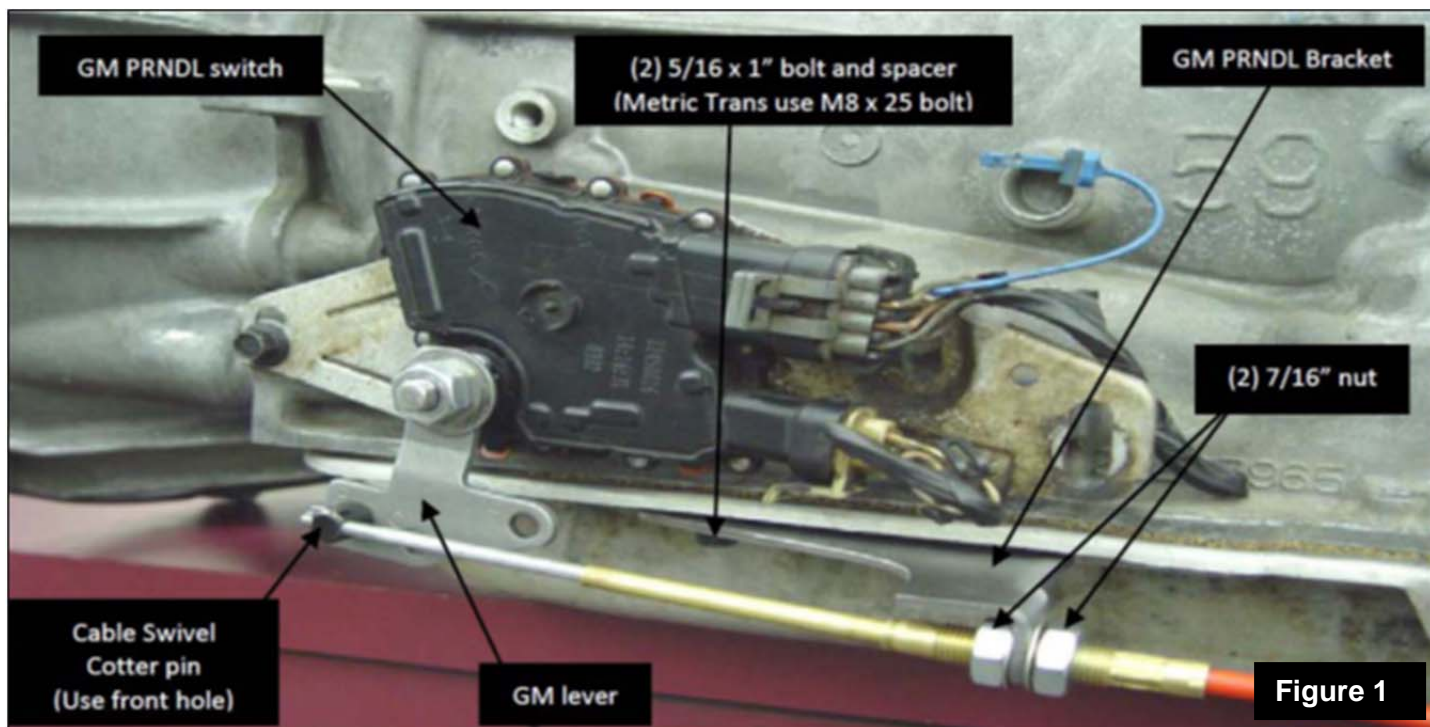

Step 2. The bracket must be installed with the two spacers between the pan and the bracket. (If your transmission is equipped with a cast aluminum oil pan, these spacers should be omitted. Install the two 5/16-18 x 1.00" bolts (Metric transmissions use the two 8mm x 25mm bolts) supplied and tighten 12-13 lb-ft. Do not overtighten as this can damage the pan gasket. (See Figure 2)

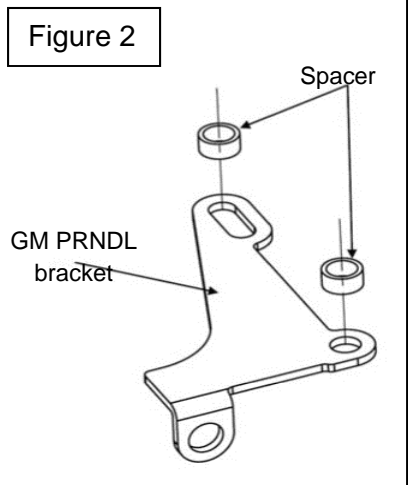

STEP 3. Route the shifter cable according to Figure #3. Avoid kinks and sharp bends and route the cable away from hot engine or exhaust parts. Remove the two rubber boots, one large nut, and a large lockwasher from the threaded end of the shifter cable. Slide the end of the cable into the cable bracket. Install the large nut and lockwasher loosely over the end of cable. Install the two rubber boots onto the end of the cable. Install the swivel on the threaded end of the cable and position it in the center of the threaded portion.

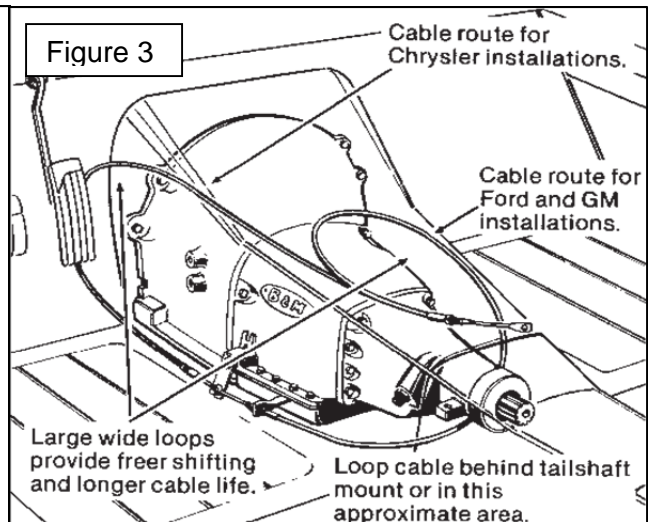

STEP 4. Move the transmission selector lever by hand to the full rear position (LOW). Place the shifter lever to the LOW gear position (all the way back). Adjust the large nuts on the cable so that the swivel will slide into the correct hole ("F" holes) on the selector lever. Tighten the large nuts completely. Be sure that the swivel will slide freely in and out of the hole in the selector lever.

Note: The shifter will not operate correctly unless the correct hole in the selector lever for your shifter is used.

Leave the swivel out of the hole and move the selector lever to PARK, all the way forward. Also move the shifter to the PARK position (all the way forward). Reinsert the swivel into the correct hole in the selector lever. Check to see that the swivel will slide freely in and out of the front hole in the selector lever in this position. If it does not slip in freely, adjust the swivel slightly until it will slip into the hole in the lever. Move the shifter back to the LOW gear position and check that the swivel will still slide easily in and out of the correct hole in the selector lever. (If you do not use the correct hole in the lever, it will be impossible to correctly adjust the cable.) Operate the shifter through all the gear positions. Check to make sure the swivel will slide in and out of the correct selector lever hole in each gear position. The shift cable is now correctly adjusted. Install the cotter key supplied with the shifter into the swivel and spread the key ends. If you have a problem, **DO NOT FORCE THE SHIFTER**, this will damage the cable, the shifter or the transmission. Simply start at the beginning and carefully check all your steps.