

# GPS Receiver and GPS Receiver/Heading Sensor



 **HUMMINBIRD**

**Accessory  
Manual**

# Thank You!

---

Thank you for choosing Humminbird®, the #1 name in Fishfinders. Humminbird® has built its reputation by designing and manufacturing top-quality, thoroughly reliable marine equipment. Your Humminbird® accessory is designed for trouble-free use in even the harshest marine environment. In the unlikely event that your Humminbird® accessory does require repairs, we offer an exclusive Service Policy - free of charge during the first year after purchase, and available at a reasonable rate after the one-year period. For complete details, see the separate warranty card included with your accessory. We encourage you to read this operations manual carefully in order to get full benefit from all the features and applications of your Humminbird® product.

***WARNING!*** *This device should not be used as a navigational aid to prevent collision, grounding, boat damage, or personal injury. When the boat is moving, water depth may change too quickly to allow time for you to react. Always operate the boat at very slow speeds if you suspect shallow water or submerged objects.*

***WARNING!*** *The electronic chart in your Humminbird® unit is an aid to navigation designed to facilitate the use of authorized government charts, not to replace them. Only official government charts and notices to mariners contain all of the current information needed for the safety of navigation, and the captain is responsible for their prudent use.*

***WARNING!*** *Compass Safe Distance: Do NOT install the Heading Sensor near ferrous metals or near anything that may create a magnetic field or interference. The Heading Sensor must be installed at least 3 feet (1m) from other magnetic or ferrous materials on the boat.*

***WARNING!*** *Humminbird® is not responsible for the loss of data files (waypoints, routes, tracks, groups, recordings, etc.) that may occur due to direct or indirect damage to the unit's hardware or software. It is important to back up your control head's data files periodically. Data files should also be saved to your PC before restoring the unit's defaults or updating the software.*

---

**WARNING!** *Disassembly and repair of this electronic unit should only be performed by authorized service personnel. Any modification of the serial number or attempt to repair the original equipment or accessories by unauthorized individuals will void the warranty.*

**WARNING!** *This product contains chemicals known to the State of California to cause cancer and/or reproductive harm.*

**ENVIRONMENTAL COMPLIANCE STATEMENT:** *It is the intention of Johnson Outdoors Marine Electronics, Inc. to be a responsible corporate citizen, operating in compliance with known and applicable environmental regulations, and a good neighbor in the communities where we make or sell our products.*

**WEEE DIRECTIVE:** *EU Directive 2002/96/EC "Waste of Electrical and Electronic Equipment Directive (WEEE)" impacts most distributors, sellers, and manufacturers of consumer electronics in the European Union. The WEEE Directive requires the producer of consumer electronics to take responsibility for the management of waste from their products to achieve environmentally responsible disposal during the product life cycle.*

*WEEE compliance may not be required in your location for electrical & electronic equipment (EEE), nor may it be required for EEE designed and intended as fixed or temporary installation in transportation vehicles such as automobiles, aircraft, and boats. In some European Union member states, these vehicles are considered outside of the scope of the Directive, and EEE for those applications can be considered excluded from the WEEE Directive requirement.*



*This symbol (WEEE wheelie bin) on product indicates the product must not be disposed of with other household refuse. It must be disposed of and collected for recycling and recovery of waste EEE. Johnson Outdoors Marine Electronics, Inc. will mark all EEE products in accordance with the WEEE Directive. It is our goal to comply in the collection, treatment, recovery, and environmentally sound disposal of those products; however, these requirements do vary within European Union member states. For more information about where you should dispose of your waste equipment for recycling and recovery and/or your European Union member state requirements, please contact your dealer or distributor from which your product was purchased.*

**ROHS STATEMENT:** *Product designed and intended as a fixed installation or part of a system in a vessel may be considered beyond the scope of Directive 2002/95/EC of the European Parliament and of the Council of 27 January 2003 on the restriction of the use of certain hazardous substances in electrical and electronic equipment.*

---

**ATTENTION INTERNATIONAL CUSTOMERS:** Products sold in the U.S. are not intended for use in the international market. Humminbird® international units provide international features and are designed to meet country and regional regulations. Languages, maps, time zones, units of measurement, and warranty are examples of features that are customized for Humminbird® international units purchased through our authorized international distributors.

**NOTE:** *Some features discussed in this manual require a separate purchase, and some features are only available on international models. Every effort has been made to clearly identify those features. Please read the manual carefully in order to understand the full capabilities of your model.*

**NOTE:** *The illustrations in this manual may not look the same as your product, but your unit will function in the same way.*

**NOTE:** *The procedures and features described in this manual are subject to change without notice. This manual was written in English and may have been translated to another language. Humminbird® is not responsible for incorrect translations or discrepancies between documents.*

---

# Table of Contents

---

<b>Overview</b>	<b>1</b>
How GPS and Trackplotting Work . . . . .	2
How the Heading Sensor Works . . . . .	3
<b>Installation Overview</b>	<b>4</b>
Choose the Mounting Location . . . . .	4
Install the Sensor . . . . .	5
Stem Mount with 1" - 14 Thread . . . . .	6
Access Under Mounting Location . . . . .	8
No Access Under Mounting Location . . . . .	10
Connect to the Control Head . . . . .	12
Power on and Confirm GPS Reception . . . . .	14
Turn on NMEA Output and Confirm the Baud Rate <i>(for devices connected to the pigtail only)</i> . . . . .	15
Confirm the Heading Sensor Operation <i>(Heading Sensors only [AS GPS HS])</i> . . . .	16
<b>Views</b>	<b>18</b>
Bird's Eye View . . . . .	19
Track View . . . . .	20
Combo View . . . . .	21
View Orientation . . . . .	22
<b>Introduction to Navigation</b>	<b>23</b>
Waypoints, Routes, and Tracks . . . . .	23
Save, Edit, or Delete a Waypoint . . . . .	25
Navigate to a Waypoint or Position . . . . .	27
Add a Waypoint Target or Trolling Grid . . . . .	28
Save or Clear a Current Track . . . . .	29
Edit, Delete, or Hide Saved Tracks . . . . .	29
<b>The Menu System</b>	<b>31</b>
<b>Start-Up Options Menu</b>	<b>32</b>
Normal . . . . .	32
Simulator . . . . .	33
System Status . . . . .	33
Self Test . . . . .	34
Accessory Test . . . . .	34
GPS Diagnostic View . . . . .	35
PC Connect <i>(with PC Connect Cable only)</i> . . . . .	36
<b>X-Press™ Menu</b>	<b>37</b>

---

# Table of Contents

---

<b>Main Menu</b>	<b>38</b>
User Mode (Normal or Advanced) . . . . .	39
<b>Sonar X-Press™ Menu (<i>Sonar Views only</i>)</b>	<b>41</b>
Mark . . . . .	42
Cancel Navigation ( <i>only when navigating</i> ) . . . . .	42
<b>Navigation X-Press™ Menu (<i>Navigation Views only</i>)</b>	<b>43</b>
Mark . . . . .	44
Zoom . . . . .	44
Go To . . . . .	44
Waypoint [Name] ( <i>only with an active cursor on a waypoint</i> ) . . . . .	44
Cursor to Waypoint ( <i>Track or Combo View only</i> ) . . . . .	45
Save Current Track . . . . .	45
Clear Current Track . . . . .	45
Skip Next Waypoint ( <i>only when navigating</i> ) . . . . .	45
Cancel Navigation ( <i>only when navigating</i> ) . . . . .	46
Remove Target ( <i>only if a target is active</i> ) . . . . .	46
Remove Grid ( <i>only if a grid is active</i> ) . . . . .	46
Sonar Window ( <i>Combo View only</i> ) . . . . .	46
Waypoint [Name] ( <i>most recently-created waypoint</i> ) . . . . .	47
<b>Alarms Menu Tab</b>	<b>48</b>
Off Course Alarm . . . . .	49
Arrival Alarm . . . . .	49
Drift Alarm . . . . .	50
<b>Navigation Menu Tab</b>	<b>51</b>
Current Track . . . . .	52
Saved Tracks . . . . .	53
Waypoints . . . . .	53
View Orientation . . . . .	54
Casting Rings ( <i>Advanced</i> ) . . . . .	54
North Reference . . . . .	54
Waypoint Proximity Flags ( <i>Advanced</i> ) . . . . .	55
Waypoint Decluttering ( <i>Advanced</i> ) . . . . .	55
Grid Rotation . . . . .	56
Trackpoint Interval . . . . .	56
Track Min Distance ( <i>Advanced</i> ) . . . . .	56

# Table of Contents

---

Track Color Range . . . . .	57
Map Datum ( <i>Advanced</i> ) . . . . .	57
North-Up Indicator . . . . .	57
Course Projection Line . . . . .	57
Heading Offset ( <i>Advanced, Heading Sensors only</i> ) . . . . .	58
Heading Line ( <i>Advanced, Heading Sensors only</i> ) . . . . .	58
Delete All Nav Data ( <i>Advanced</i> ) . . . . .	58
Continuous Navigation Mode . . . . .	58
GPS Receiver Override ( <i>Advanced</i> ) . . . . .	59
<b>Setup Menu Tab</b> . . . . .	<b>60</b>
Units - Distance . . . . .	61
Units - Speed . . . . .	61
Triplog Reset . . . . .	61
Select Readouts ( <i>Advanced, Sonar View only</i> ) . . . . .	62
Local Time Zone ( <i>Advanced</i> ) . . . . .	63
Daylight Saving Time ( <i>Advanced</i> ) . . . . .	64
Position Format ( <i>Advanced</i> ) . . . . .	64
Time Format ( <i>Advanced, International only</i> ) . . . . .	64
Date Format ( <i>Advanced, International only</i> ) . . . . .	64
NMEA Output ( <i>Advanced</i> ) . . . . .	65
<b>Troubleshooting</b> . . . . .	<b>66</b>
Fishing System Doesn't Power Up . . . . .	66
Fishing System Defaults to Simulator with a Transducer Attached . . . . .	66
Display Problems . . . . .	67
Finding the Cause of Noise . . . . .	68
<b>GPS &amp; Navigation Glossary</b> . . . . .	<b>69</b>
<b>Contact Humminbird®</b> . . . . .	<b>73</b>

---

## Overview

---

The Humminbird® Sensor Accessory Kit includes the following items depending on the Sensor model you purchased:

### GPS Receiver (AS GR16, AS GR50, AS GRP)

Sensor with internal GPS Receiver.  
Cable length is 20 ft (6m).

Y-Cable (AS YC) for multiple accessory attachment

Hardware kit for stem or deck mounting

Accessory Manual

### GPS Receiver/Heading Sensor (AS GPS HS)

Sensor with internal GPS Receiver and Compass. Cable length is 20 ft (6m).

Y-Cable (AS YC) for multiple accessory attachment

Hardware kit for stem or deck mounting

Accessory Manual

The following functionality will be supported by your trackplotter when it is connected to the Sensor:

- View current position
- View current track (breadcrumb trail)
- View precision speed and heading from your GPS receiver
- Save tracks and waypoints
- Travel a route and navigate from one waypoint to the next
- View the heading from the Heading Sensor (AS GPS HS only)

**NOTE:** *If your control head is a chartplotter, there will be additional functionality when the Sensor is connected to the control head. See your control head operations manual and the Humminbird® Waypoint Management Guide for more information.*



## How GPS and Trackplotting Work

---



Your Humminbird® uses GPS to determine your position and display it on a grid.

GPS uses a constellation of satellites that continually send radio signals to the earth. The GPS receiver on your boat receives signals from satellites that are visible to it. Based on time differences between each received signal, the GPS receiver determines its distance to each satellite. With distances known, the GPS receiver mathematically triangulates its own position. With 5 updates per second, the GPS receiver then calculates its velocity and bearing.

GPS was originally intended for military use; however, civilians may also take advantage of its highly accurate position capabilities, typically within  $\pm 2.5$  to 10 meters, depending on your conditions and your Humminbird® model. This means that 95% of the time, the GPS receiver will read a location within  $\pm 2.5$  to 10 meters of your actual position.

Your GPS receiver also uses information from WAAS (the Wide Area Augmentation System), EGNOS (the European Geostationary Navigation Overlay Service), and MSAS (the MTSAT Satellite Augmentation System) satellites if they are available in your area.

## How the Heading Sensor Works

---

The magnetic compass is one of the first known instruments for navigation. It relies on the earth's magnetic field to align a magnetic pointer towards North, also known as Magnetic North.

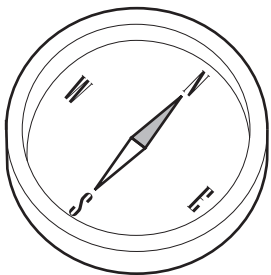

If your accessory includes a Heading Sensor, the control head will display the heading from the internal compass in digital format. The Heading is the direction the boat is pointing, where  $000^\circ$  is North,  $090^\circ$  is East,  $180^\circ$  is South, and  $270^\circ$  is West.

Due to wind and waves, the boat is often traveling in a slightly different direction than its heading. The direction of travel, or Course Over Ground, is provided by the GPS receiver. You can use the compass Heading with the GPS Course Over Ground and Bearing to navigate a route.

A compass' Magnetic North is affected by the local variations in the earth's magnetic field around the globe. Nautical charts will often provide the magnetic declination, or magnetic variation, for a local area so that you can confirm that Magnetic North matches True North. If you have trailered the boat to a new location, the compass' operation may also be affected by a different magnetic zone. The Humminbird® control head compensates for magnetic declination and also allows you to make additional adjustments from the menu system. The details of these features are described in this manual.

# Installation Overview

---

Use the following instructions to install the Sensor accessory on your boat. In order to understand the installation requirements, we recommend that you read the instructions carefully before you start the installation.

**Required Supplies:** In addition to the hardware included with your Sensor accessory kit, you will need a drill, electrical tape, and an awl or pencil. Depending on your installation requirements, you might also need to purchase extension cables or a stem. See **Section 1: Choose the Mounting Location** for more information.

## 1. Choose the Mounting Location

---

It is important to consider the following information when you choose a mounting location for the Sensor:

- **Interference:** Do NOT mount the Sensor close to a VHF antenna or within the active area of a radar. **If the Sensor includes a compass (AS GPS HS)**, do NOT install it near ferrous metals or near anything that can create a magnetic field. Hardware and cables that handle large currents, such as batteries and power cables, are also examples of equipment that may cause interference.
- **Reception:** Mount the Sensor in an area that has full exposure to the sky. The effective area of reception is 5° above the horizon.
- **Surface:** Whether the Sensor Cable will be routed down through the mounting surface or to the side, or if you're using a stem mount, the mounting surface will influence how you install the Sensor. For details, see **Section 2: Install the Sensor**.
- **Cables:** Test run the Sensor Cable from the chosen mounting location to the Control Head. 10 ft (3m) extension cables may be purchased from Humminbird® if your planned cable route exceeds 20 ft (6 m). Maximum cable length, including extension cables, should not exceed 50 ft (16 m).

## 2. Install the Sensor

There are three different options to mount the sensor. Proceed to the section that matches the type of mounting location you will be using, as follows:

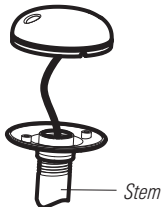

### Stem Mount with 1" - 14 Thread

The sensor will be mounted on a stem or antenna pole. ***Proceed to Section A.***



*Cable routed through the hole*

### Access Under the Mounting Deck

The sensor will be deck mounted and the cable can be routed down through the mounting surface. ***Proceed to Section B.***



*Cable routed to the side*

### NO Access Under the Mounting Deck

The sensor will be deck mounted and the cable must be routed to the side because there is not space for a cable through or underneath the mounting location. ***Proceed to Section C.***

## A. Stem Mount with 1"-14 Thread

Use the following instructions to stem mount the Sensor:

**WARNING!** If your Sensor includes a compass (AS GPS HS), do NOT mount it to a stem mount or antenna pole that contains ferrous metals.

**NOTE:** It is important to review the mounting considerations and test run the cable route as indicated in Section 1 before proceeding with the installation.

1. If you have a pre-existing stem mount, skip to step 2.

If you need to mount the antenna pole (stem), mark the chosen mounting location and drill a 3/4" (19 mm) hole for the cable and cable connector.

If you have purchased hardware to stem mount your Sensor, follow the instructions included with that hardware to attach the stem to the boat.

2. Screw the sensor base onto the stem first, making sure that the stem pipe does not protrude from the sensor base. (This adds protection to the cable when it is pulled through the pipe stem.) Deburr the pipe edges to reduce cable abrasion.
3. Use electrical tape to secure the NMEA pigtail to the cable.

**NOTE:** Unless it is needed, leave the NMEA pigtail secured to the cable. If you are connecting the pigtail to a NMEA 0183 device, see **Section 3: Connect to the Control Head** for connection information.

Stem Mount, Attaching the Sensor Base to the Stem

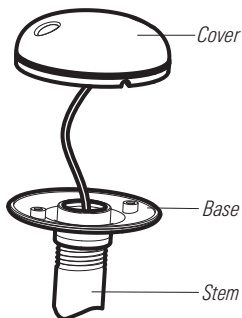

Taping the NMEA Pigtail to the Cable

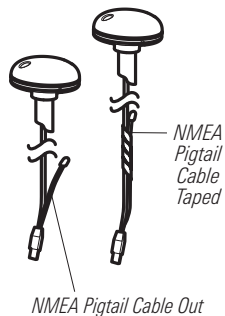

4. Route the Sensor cable through the stem and through the planned cable route. To use extension cables, see the details in **Section 1: Choose the Mounting Location**.

5. If the Sensor includes a compass (AS GPS HS), position the sensor so the arrow on the cover is pointed straight toward the front of the boat in the direction of travel. The arrow should be parallel with the keel.

**NOTE:** Failure to align the sensor correctly will result in incorrect compass readings.

6. Attach the Sensor to its base using the included #6 -1/4" screws. **Hand tighten only.**

#### Positioning the Arrow on the Compass

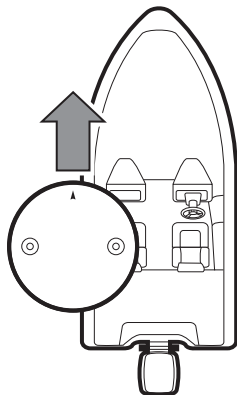

#### Attaching the Sensor to the Base

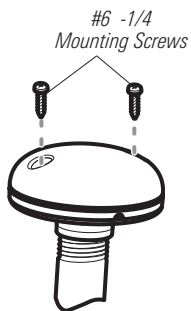

## B. Access Under Mounting Location

Use the following instructions to deck mount the Sensor and route the cable down through the mounting surface:

**NOTE:** It is important to review the mounting considerations and test run the cable route as indicated in Section 1 before proceeding with the installation.

1. Mark the mounting location and drill a 3/4" (19 mm) hole for the cable and cable connector.
2. Secure the NMEA pigtail to the cable with electrical tape.

**NOTE:** Unless it is needed, leave the NMEA pigtail secured to the cable. If you are connecting the pigtail to a NMEA 0183 device, see **Section 3: Connect to the Control Head** for connection information.

3. Route the Sensor cable through the planned cable route. To use extension cables, see the details in **Section 1: Choose the Mounting Location**.
4. Cover the cable hole with the Sensor.

**If the Sensor includes a compass (AS GPS HS),** position the sensor so the arrow on the cover is pointed straight toward the front of the boat in the direction of travel. The arrow should be parallel with the keel.

**NOTE:** Failure to align the sensor correctly will result in incorrect compass readings.

5. Make sure the Sensor is flush against the surface, and mark the two mounting holes with a pencil or awl.

### Taping the NMEA Pigtail to the Cable

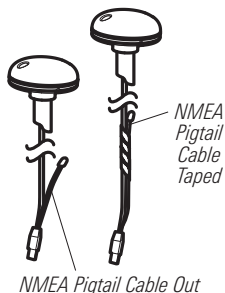

6. Move the Sensor to the side and drill two pilot holes, using a 5/32" (4 mm) bit.

**NOTE:** Apply marine-grade silicone caulk or sealant to both screw and drilled holes as needed to protect your boat from water damage.

7. Align the Sensor's screw holes over the pilot screw holes and attach with the #6 - 3/4" Phillips head screws. **Hand tighten only.**

**NOTE:** If the mounting surface is thin or made of a light-weight material, you may need to add reinforcing material below the mounting surface in order to support the Sensor.

**Positioning the Arrow  
on the Compass**

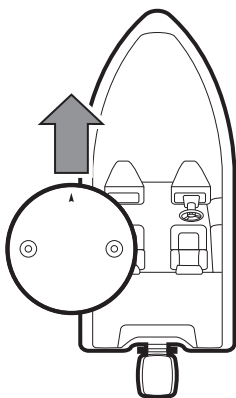

**Attaching the Sensor to the  
Mounting Surface**

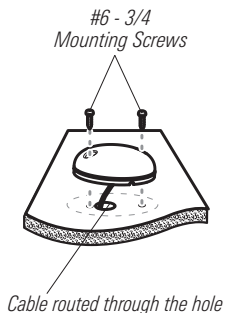



## C. No Access Under Mounting Location

Use the following instructions to deck mount the Sensor and route the cable to the side if there is not space for a cable underneath the mounting location.

**NOTE:** It is important to review the mounting considerations and test run the cable route as indicated in Section 1 before proceeding with the installation.

1. Secure the NMEA pigtail with electrical tape.

**NOTE:** Unless it is needed, leave the NMEA pigtail secured to the cable. If you are connecting the pigtail to a NMEA 0183 device, see **Section 3: Connect to the Control Head** for connection information.

2. Route the cable from the Sensor to the Control head.

- The Sensor has two wire routing notches. Use the cable notch closest to the intended cable route.
- If holes are required to route the cable, they must be 3/4" (19mm) to allow for the cable connector.
- To use extension cables, see the details in **Section 1: Choose the Mounting Location**.

### Taping the NMEA Pigtail to the Cable

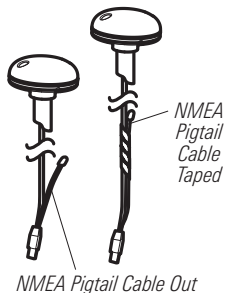

3. With the cable routed, position the Sensor in the planned mounting location.

**If the Sensor includes a compass (AS GPS HS),** position the sensor so the arrow on the cover is pointed straight toward the front of the boat in the direction of travel. The arrow should be parallel with the keel.

***NOTE:** Failure to align the sensor correctly will result in incorrect compass readings.*

4. Make sure the Sensor is flush against the surface, and mark the two mounting holes with a pencil or awl.
5. Move the Sensor to the side and drill the two 5/32" (4 mm) pilot holes.

***NOTE:** Apply marine-grade silicone caulk or sealant to both screw and drilled holes as needed to protect your boat from water damage.*

6. Align the Sensor's screw holes over the pilot screw holes and attach with the #6 - 3/4" Phillips head screws. **Hand tighten only.**

#### Positioning the Arrow on the Compass

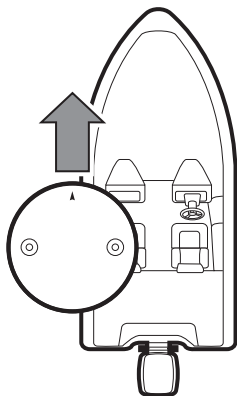

#### Attaching the Sensor to the Mounting Surface

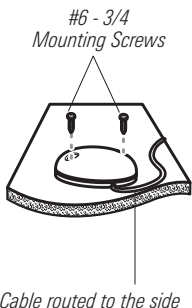

### 3. Connect to the Control Head

---

Use the following instructions to connect the Sensor cable to the control head.

1. Insert the Sensor's NMEA-COM connector into the control head's COM port. The connectors are keyed to prevent reversed installation, so be careful not to force the connector into the port.
  - If there is another accessory plugged into the COM port, you will need to install the AS YC ("Y") cable so that you can use the accessories at the same time.
  - Attach the COM connector of the "Y" cable directly to the control head COM port. Connect the Sensor to the NMEA-COM connector of the "Y" cable. Re-connect your other Fishfinder accessories to the ACCY-COM connector of the "Y" cable.
2. **Optional:** You can connect an optional-purchase device, such as an autopilot, to the Sensor pigtail wires.

The pinouts are as follows:

- **Black Wire (Ground)**
- **White Wire (Control Head NMEA Out):** outputs the navigation calculations and commands from the control head as IN (Integrated Navigation) NMEA sentences. Connect the white wire to the device's NMEA In wire.

**OR**

- **Green Wire (GPS NMEA Out):** outputs GP (Global Positioning) NMEA sentences directly from the Sensor. Connect the green wire to the device's NMEA In wire if it can only read GP NMEA sentences.

***NOTE:** See your device installation guide to identify the NMEA In wire. The device will connect to the white wire or green wire, depending on its NMEA communication requirements (IN or GP).*

***NOTE:** See **Section 5: Turn on NMEA Output and Confirm the Baud Rate** for more information.*

**WARNING!** It is important to finish all installation connections before powering on the control head.

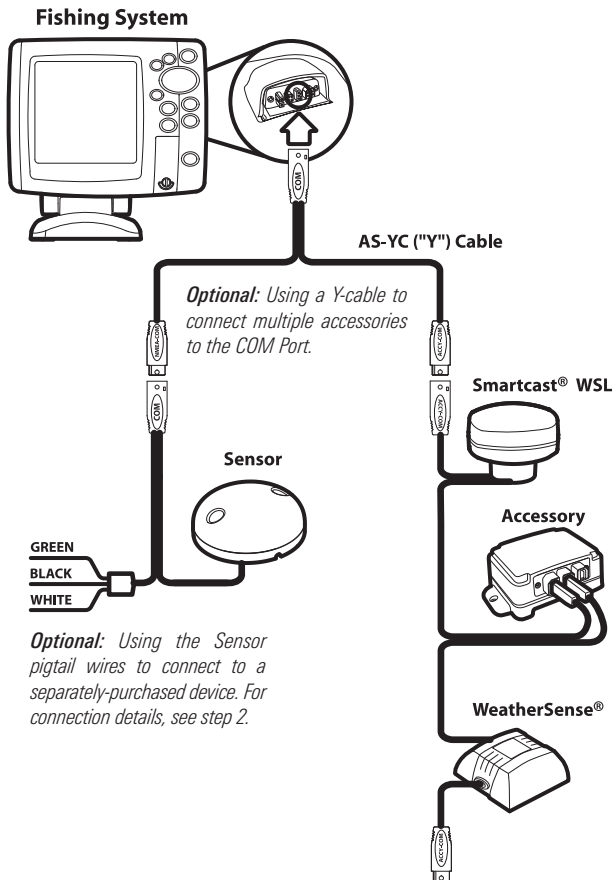

## 4. Power on and Confirm GPS Reception

Follow the instructions below to power on your Humminbird® control head.

788ci HD Title Screen



GPS Diagnostic View

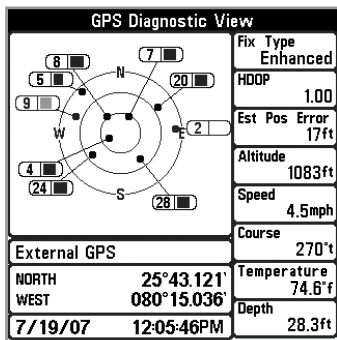

1. Press the  POWER/LIGHT key.
2. When the Title screen is displayed, press the MENU key to access the Start-Up Options Menu.
3. If a functioning transducer is connected, Normal operation will be selected automatically, and your Fishing System can be used on the water. See ***Start-Up Options Menu*** for more information.
4. Press the VIEW key until the GPS Diagnostic View is displayed on the screen. Confirm that External GPS is displayed and the Fix Type indicates Enhanced or 3D.
  - If the GPS Diagnostic View is not displayed in the rotation, press the MENU key twice to open the Main Menu. Select the Views tab > GPS Diagnostic View > Visible.
  - If it is connected and detected, the Sensor will also be displayed in the Accessory Test screen (see ***Start-Up Options Menu***).

## 5. Turn on NMEA Output and Confirm the Baud Rate

*(for devices connected to the pigtail only)*

---

If you connected a device to the Sensor pigtail wires, turn on NMEA Output to enable communication and output NMEA 0183 sentences from the control head. It is also important to note the following:

- **If the GPS Receiver/Heading Sensor (AS GPS HS) is connected to the control head, and NMEA Output is turned on**, the control head will operate exclusively at a baud rate of 38400. If there is an accessory attached to the Sensor's pigtail, it also needs to operate at 38400. See your accessory installation guide to set the baud rate to 38400.
- **If a GPS Receiver (AS GR16, AS GR50, AS GRP) is connected to the control head, and NMEA Output is turned on**, the control head will operate exclusively at a baud rate of 4800. If there is an accessory attached to the Sensor's pigtail, it also needs to operate at 4800. See your accessory installation guide to set the baud rate to 4800.
- **If NMEA Output is turned off**, then baud rates 4800, 9600, and 38400 are available on the control head, but the device will not receive NMEA data.

### Turn On/Off NMEA Output

1. Press the MENU key twice.
2. Select Setup tab > NMEA Output.
3. Press the RIGHT or LEFT Cursor keys to select On or Off. (Default = Off)

**NOTE:** *The menu option in your Fishing System will be called NMEA 0183 Output or NMEA Output. If the menu option is not shown under the Setup tab, make sure the User Mode is set to Advanced (Setup tab > User Mode > Advanced).*

**NOTE:** *See Setup Menu Tab: NMEA Output for more information about the NMEA sentences available on the control head.*

## 6. Confirm the Heading Sensor Operation

*(Heading Sensors only [AS GPS HS])*

---

It is important to confirm that the Heading Sensor is installed correctly by reviewing the heading digital readout.

**NOTE:** *This procedure should be performed at slow speeds, in calm, open water, in a large area that is far from shallow water, boats, or other obstacles.*

1. Press the MENU key twice to open the Main Menu.
2. Select Navigation tab > North Reference > Magnetic.
3. Press the EXIT key.
4. Select Setup tab > Select Readouts.

**NOTE:** *If the Select Readouts menu option does not appear under the Setup tab, change the User Mode to Advanced. Select Main Menu > Setup tab > User Mode > Advanced.*

5. Select a Readout position and use the RIGHT or LEFT Cursor keys to select Heading. Select another Readout position and select Course.
6. Press the EXIT key until the Main Menu is closed.
7. Press the VIEW key until the Sonar View is displayed on the screen.
8. Navigate the boat in a straight line, in calm, open water at 4.5 mph. Compare the Heading digital readout on the screen with the Course (COG) digital readout. The readouts should be within approximately 5° of each other.

**Adjust:** To adjust the zero point of the Heading Sensor, select Main Menu > Navigation tab > Heading Offset. Press the RIGHT or LEFT Cursor keys to adjust the setting.

**If the procedure failed:** If the Heading digital readout is significantly different than the COG, the Heading Sensor might be installed in a location with too much magnetic interference. Check the installation location and possible magnetic disturbances in the area.

### Confirming the Heading Digital Readout (1198c SI, Chart View)

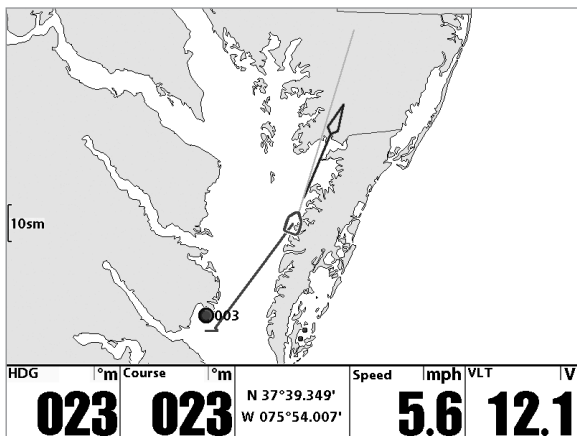

Heading  
(Heading Sensor Required)

Course  
(GPS Required)

### Confirming the Heading Digital Readout (788ci HD, Sonar View)

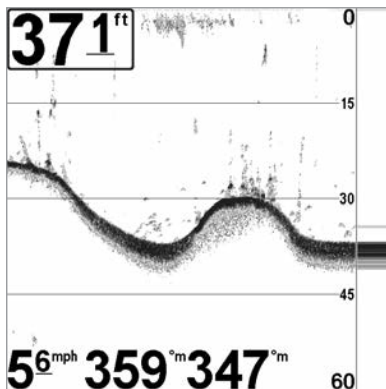

Heading  
(Heading Sensor Required)

Course  
(GPS Required)



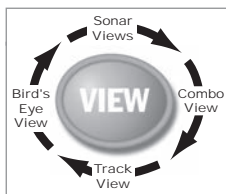

## Views

---

The following views will be added to the View Rotation when the Sensor is connected to the trackplotter:

### Navigation views:

- Bird's Eye View
- Track View
- Combo View

**If the Sensor is connected to a chartplotter**, the following views will be added to the view rotation: Bird's Eye View, Chart View, and Combo View. For details about the navigation views and menu options, see your control head operations manual and the Waypoint Management Guide.

## Bird's Eye View

**Bird's Eye View** shows a 3-D, perspective view of the track from a point above and behind the boat (the eye point). As the boat turns, the eye point moves to follow the boat.

- **To shift the eye point position** so that you can look off to the sides, or even behind the boat: Press the RIGHT or LEFT Cursor keys to turn the eye point right or left. Press the UP Cursor key to move the eye point forward, and press the DOWN Cursor key to move the eye point backward.
- Press the **EXIT key** to move the eye point back to its original position behind and above the boat.

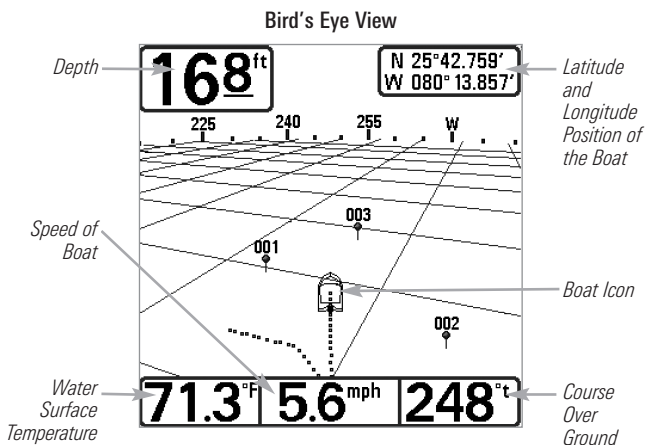

## Track View

**Track View** shows the current track (also known as the position history or breadcrumb trail) showing where the boat has been, along with saved tracks, waypoints, and the current route (when navigating).

**Panning:** Use the 4-WAY Cursor Control key to move the grid around on the display in the direction of the key being pressed. When you do this, a cursor is drawn at the center of the screen and is linked to the boat by a gray line, even if the boat is off the screen.

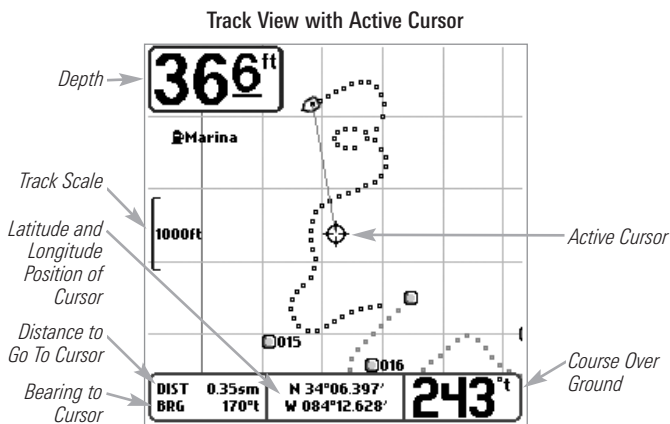

## Combo View

**Combo View** is displayed as a split screen, with Track View on the left and Sonar View on the right side of the screen. To change the width of the Sonar Window, press the MENU key once and select Sonar Window from the X-Press™ Menu.

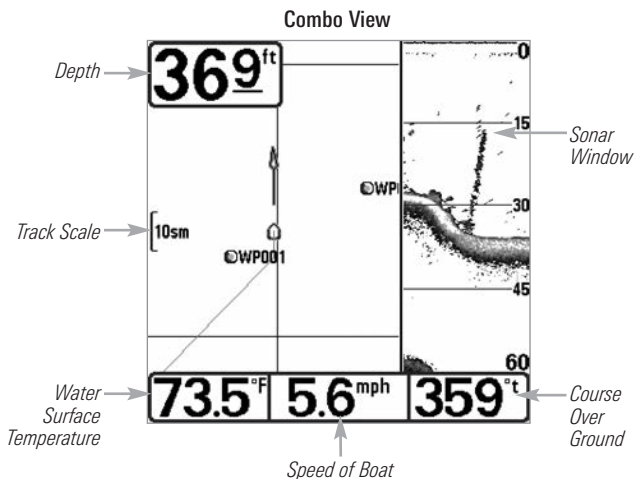

## View Orientation

The Track View and Combo View allow you to choose the orientation of the view (see *Navigation Menu Tab: View Orientation*).

**NOTE:** If you have a chartplotter, the menu option is called *Chart Orientation* (select *Main Menu > Chart tab > Chart Orientation*).

- **North-Up:** North is shown at the top of the display. Objects located to the north of the boat are drawn above the boat.
- **Head Up:** The boat's current heading points up, and the track rotates around the boat so that the boat always points up on the view. The heading is provided by the Heading Sensor connected to the control head. If a Heading Sensor is not connected, the heading will be calculated using the GPS receiver's COG (Course Over Ground).
- **Course-Up:** During navigation, the projected course is shown at the top of the view. Objects ahead of the boat are drawn above the boat. When the boat is not navigating, the course-up reference is provided by the COG (Course Over Ground) calculation.

**North-Up Icon:** If it is turned on, the North-Up Icon displays the direction of True North. It also displays the View Orientation, and the icon will change as the orientation and the data source change (see *Navigation Menu Tab: North-Up Indicator*).



When the boat is stationary, it is drawn as a circle.



When the boat is in motion, it changes to a boat shape, pointed in the direction of motion.

**NOTE:** If a Heading Sensor (AS GPS HS) is attached, the boat icon will always be displayed as a boat shape. It will not change to a circle when the boat is stationary.

# Introduction to Navigation

Your trackplotter allows you to mark waypoints and start navigation with the Navigation X-Press™ Menu.

*NOTE: For details about chartplotters and navigation, see your control head operations manual and the Waypoint Management Guide.*

## Waypoints, Routes, and Tracks

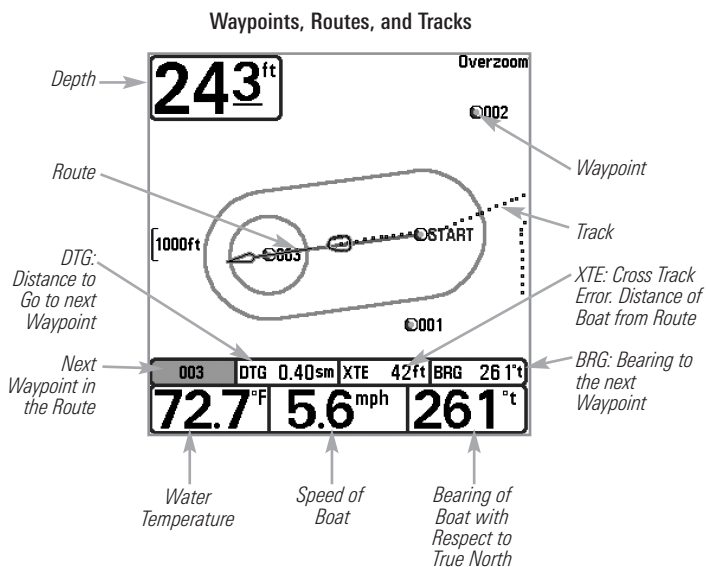

**Waypoints** are stored positions that allow you to mark areas of interest or navigation points.

**Routes** link two or more waypoints together to create a path for navigation and are used in trip planning. You can link individual waypoints together by using the GOTO key or the Go To menu option (see *Navigation X-Press™ Menu*).

A route represents your intended navigation and shows the shortest path from each waypoint to the next. As you travel a route, staying on the route line is the most efficient way to get to your destination, although you should always look out for obstacles not shown on the track. A **Route Leg** is the path between each waypoint in a route. In color models, the color of each route leg is displayed as follows:

- Completed Route Leg = Gray
- Current Route Leg = Green
- Future Route Leg = Gold

**Tracks** consist of a detailed position history and are displayed as a breadcrumb trail of trackpoints. The Current Track shows the position history since the unit was powered up. You can clear the Current Track or save it at any time. The current track represents your actual path so far.

***NOTE:** The maximum number of waypoints, routes, and tracks may vary due to your Humminbird® control head model. See your control head operations manual for details.*

## Save, Edit, or Delete a Waypoint

---

**Save your current position as a waypoint:** On the Track or Combo view, press the MENU key to display the X-Press™ Menu. Select Mark, and press the RIGHT Cursor key to save the boat position as a waypoint.

**Save the cursor position as a waypoint:** On the Track or Combo view, use the 4-WAY Cursor Control key to move the cursor to the position you want to save as a waypoint. Then, press the MENU key to display the X-Press™ Menu. Select Mark, and press the RIGHT Cursor key to save the cursor position as a waypoint.

**Save a position from the sonar history:** On the Sonar view, use the 4-WAY Cursor Control key to move the cursor to a feature in the sonar history. Then press the MENU key to display the X-Press™ Menu. Select Mark, and press the RIGHT Cursor key to create a waypoint at the location where that sonar reading was taken. The new waypoint will also record the depth at that location.

***NOTE:** When you save a waypoint by any of these methods, a numerical waypoint name is automatically assigned. You can edit the waypoint information later to give it a different name and select an icon to represent it (see **Program or Edit the Waypoint Fields**).*

**Display the Waypoints submenu:** From any view, press the MENU key twice to display the Main Menu, then press the RIGHT Cursor key to select the Navigation tab. Select Waypoints, and press the RIGHT Cursor key to display the Waypoints submenu.

**Program a specific position as a waypoint:** To create a waypoint that is NOT your current position, from the Waypoints submenu select Create, and press the RIGHT Cursor key. Use the 4-WAY Cursor Control key to program the waypoint name, latitude, longitude, and icon before selecting Save.



**Edit a waypoint:** From the Waypoints submenu, select Edit and press the RIGHT Cursor key to display the saved waypoints list. Select the waypoint you want to edit and press the RIGHT Cursor key. Use the 4-WAY Cursor Control key to edit the waypoint name, latitude, longitude, and icon before selecting Save.

To make it easier to select a waypoint to edit, select **Sort By** and press the RIGHT or LEFT Cursor keys to select a sort order:

- **Name** shows the waypoints alphabetically.
- **Time** shows the most recently-created waypoint first.
- **Distance** shows the closest waypoint first.

**Program or Edit the waypoint fields:** Use the 4-WAY Cursor Control key to move from field to field, and use the UP or DOWN Cursor keys to change the character in the field.

In the Waypoint Name, Latitude, and Longitude fields, press the UP or DOWN Cursor keys to change the letter or number. All upper and lower case letters are available, as well as digits 0-9 and some punctuation characters.

In the Waypoint Icon field, press the UP or DOWN Cursor keys to change the icon used to represent the waypoint on the Combo and Track Views. To exit these fields, press the LEFT or RIGHT Cursor keys or press the EXIT key.

**Delete a waypoint:** From the Waypoints submenu, select Delete, and press the RIGHT Cursor key to display the saved waypoints list. Select the waypoint you want to delete, then press the RIGHT Cursor key. You will be asked to confirm deletion before the waypoint is permanently deleted.

## Navigate to a Waypoint or Position

---

**Navigate to the cursor position:** From the Track or Combo view, use the 4-WAY Cursor Control key to move the cursor to a position or waypoint on the display. Press the MENU key once to display the Navigation X-Press™ Menu. Select Go To, and press the RIGHT Cursor key. Navigation will begin immediately.

**Navigate to a specified waypoint:** Press the MENU key once to display the Navigation X-Press™ Menu. Select Go To, and press the RIGHT Cursor key. Press the DOWN Cursor key to select a waypoint from the saved waypoints list, and press the RIGHT Cursor key to start navigation.

***NOTE:** By repeating the previous instructions, you can add more waypoints to create a longer multi-segment route.*

***NOTE:** When two or more waypoints overlap, or are displayed close together on a track view, the screen will automatically declutter—waypoint names will shorten and the waypoint icons will change into small blue icons.*

*To view a **Decluttered Waypoint** at full size, use the 4-WAY Cursor Control key to move the cursor onto a decluttered waypoint icon. When the cursor snaps onto the icon, the full-size waypoint name and icon will be displayed.*

**Skip a waypoint:** From the Navigation X-Press™ Menu, select Skip Next Waypoint and press the RIGHT Cursor key. If there is not another waypoint to skip to, navigation will be cancelled.

**Cancel navigation:** From the Navigation X-Press™ Menu, select Cancel Navigation and press the RIGHT Cursor key. Canceling navigation removes the route and any created waypoints.

## Add a Waypoint Target or Trolling Grid

The **Waypoint Target** shows a target consisting of concentric circles in various distance ranges centered on the waypoint you choose. The **Trolling Grid** shows various distance ranges in grid format from the waypoint you choose. The trolling grid can be used as a guide when trolling around a waypoint.

Track View with Target

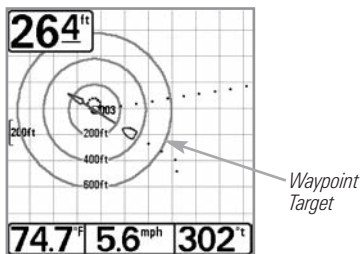

Track View with Grid

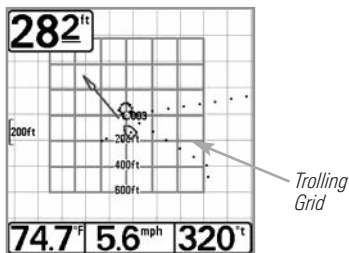

**Add a Waypoint Target:** From the Waypoints submenu, select Target, and press the RIGHT Cursor key to display the saved waypoints list. Select a waypoint and press the RIGHT Cursor key.

**Add a Trolling Grid:** From the Waypoints submenu, select Grid, and press the RIGHT Cursor key to display the saved waypoints list. Select a waypoint and press the RIGHT Cursor key. The grid can also be rotated to any heading by adjusting the Grid Rotation setting on the Navigation Main Menu.

**Remove the Target or Trolling Grid:** Press the MENU key once, choose Remove Target or Remove Grid from the Navigation X-Press™ Menu, and press the RIGHT Cursor key.

**NOTE:** Only one waypoint can have a target or a grid applied to it at one time. If you apply a target or a grid to a new waypoint, the original waypoint will lose its target or grid.

**NOTE:** The spacing of the rings on the waypoint target and the spacing of the grid lines on the trolling grid are the same as the length of the scale bar on the left edge of the display. Zooming in or out will decrease or increase the spacing, respectively.

## Save or Clear a Current Track

---

**Save the current track:** From the Navigation X-Press™ Menu, select Save Current Track and press the RIGHT Cursor key. The track will remain on the display but will change from black to gray. To remove the track completely from the display, see *Edit, Delete, or Hide Saved Tracks*.

*NOTE: When you save a track, a name is automatically assigned to it. The track name consists of a date/time stamp, but it can be re-named later (see **Edit a Saved Track**).*

**Clear the current track:** From the Navigation X-Press™ Menu, select Clear Current Track, and press the RIGHT Cursor key. The track will be removed from the display and permanently deleted.

## Edit, Delete, or Hide Saved Tracks

---

**Display the Saved Tracks submenu:** From any view, press the MENU key twice to display the Main Menu, then press the RIGHT Cursor key to select the Navigation tab. Select Saved Tracks, and press the RIGHT Cursor key to display the Saved Tracks submenu.

**Edit a saved track:** From the Saved Tracks submenu, select Edit, and press the RIGHT Cursor key to display the saved tracks list. Select the track you want to edit, and press the RIGHT Cursor key.

When the **Edit Track dialog box** appears, use the 4-WAY Cursor Control key to move between fields. In the Name field, press the UP or DOWN Cursor keys to change the letter or number. All upper and lower case letters are available, as well as digits 0-9 and some punctuation characters. To exit the Name field, press the LEFT or RIGHT Cursor keys or press the EXIT key. Select Save, and press the RIGHT Cursor key to save your changes.

**Delete a saved track:** From the Saved Tracks submenu, select Delete, and press the RIGHT Cursor key to display the saved tracks list. Select the track you want to delete, and press the RIGHT Cursor key. You will be asked to confirm deletion before the track is permanently deleted.

**Hide or display a saved track:** From the Saved Tracks submenu, select Edit, and press the RIGHT Cursor key to display the saved tracks list. Select a track, and press the RIGHT Cursor key. Select the Visibility field, and press the UP or DOWN Cursor keys to select Hidden or Visible. Press the EXIT key to return to the Saved Tracks submenu.

# The Menu System

---

The Menu System is divided into easy-to-use menu modules. The main components of the menu system are as follows:

- **Start-Up Options Menu:** Press the MENU key during the power on sequence to view the Start-Up Options Menu. From the Start-Up Options Menu, you can choose the following Fishing System Modes: Normal, Simulator, System Status, and PC Connect.
- **X-Press™ Menu:** The X-Press™ Menu provides a shortcut to the most frequently-used settings, and the options on the X-Press™ Menu correspond with the current view.
- **Main Menu:** The Main Menu is a standard set of menu settings which are organized under the following tabbed headings: Alarms, Sonar, Navigation, Chart, Setup, Views, and Accessories.

***NOTE:** The X-Press™ Menu(s) and the Main Menu options can also be expanded or simplified by setting the User Mode to Advanced or Normal (see **Main Menu: User Mode**).*

When you connect a Humminbird® GPS Receiver or GPS Receiver/Heading Sensor to the control head, the related navigation menu options will be added to the menu system.

## Start-Up Options Menu

---

Press the MENU key during the power on sequence to view the Start-Up Options Menu, and select one of the modes described on the following pages. Also, see *Power on and Confirm GPS Reception* for additional information.

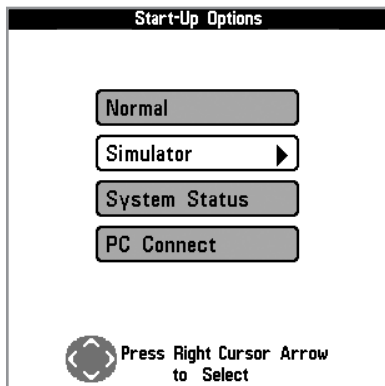

### Normal

---

Use **Normal** for on-the-water operation with a transducer connected. If a functioning transducer is connected, Normal operation will be selected automatically at power up, and your Fishing System can be used on the water.

To exit Normal operation, power off your Fishing System.

## Simulator

---

Use **Simulator** to learn how to use your Fishing System before taking your boat on the water. The Simulator is a very powerful tool that provides a randomly-updated display which simulates on the water operation.

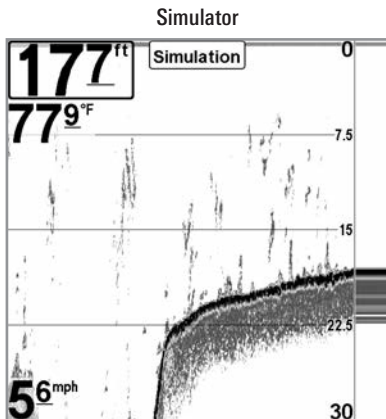

We recommend going through this manual while using the Simulator, since all the menu function and affect the display in the same way as they would in Normal operation. Any menu changes you make will be saved for later use.

**NOTE:** It is important to select Simulator manually from the Start-Up Options Menu as opposed to letting the Fishing System enter Simulator automatically (as it will if a transducer is not connected and you do nothing during power up).

A message will appear often on the display to indicate Simulator mode.

To exit Simulator, power off your Fishing System.

## System Status

---

Use **System Status** to view system connections and to conduct a unit self-test.

After you select System Status from the Start-Up Options Menu, press the VIEW key to display the following options:

- Self Test
- Accessory Test
- GPS Diagnostic View

To exit System Status, power off your Fishing System.



## Self Test Screen

SYSTEM STATUS	
Self Test	
PASSED	
S/N	MODEL
101027030037	788
SOFTWARE VERSION	
5.090	
VOLTAGE	TOTAL TIME
12.4 <sup>V</sup>	0 <sup>hrs</sup>
PCB S/N	
101027000030037	
IP ADDRESS	MAC ADDRESS
.....	00-1a-29-00-66-5f
Press VIEW for Next Screen	

**Self Test** displays results from the internal diagnostic self test, including unit serial number, Printed Circuit Board (PCB) serial number, software revision, total hours of operation, and the input voltage.

## Accessory Test

SYSTEM STATUS	
ACCESSORY TEST	
CannonLink	UNCONNECTED
GPS	CONNECTED
InterLink	UNCONNECTED
SmartCast WSL	UNCONNECTED
Speed	CONNECTED
Temperature	CONNECTED
WeatherSense	UNCONNECTED

**Accessory Test** lists the accessories connected to the system.

**NOTE:** The speed accessory will be detected only if the paddlewheel has moved since your Fishing System was powered up.

## GPS Diagnostic View

**GPS Diagnostic View** shows a sky chart and numerical data from the GPS receiver. The sky chart shows the location of each visible GPS satellite with its satellite number and a signal strength bar. A dark gray bar indicates that the satellite is being used to determine your current position. A light gray bar indicates that the satellite is being monitored but not used.

**NOTE:** The GPS Diagnostic View only appears if the GPS receiver is connected.

This view also reports the current position, local time and date, and other numeric information. The current GPS Fix Type is reported as No Fix, 2D Fix, 3D Fix, or Enhanced. An Enhanced fix has been augmented using information from WAAS, EGNOS, or MSAS. A 3D or Enhanced Fix is required for navigation. HDOP (the Horizontal Dilution of Precision) is a GPS system parameter which depends on the current satellite configuration. HDOP is used to calculate the Estimated Position Error.

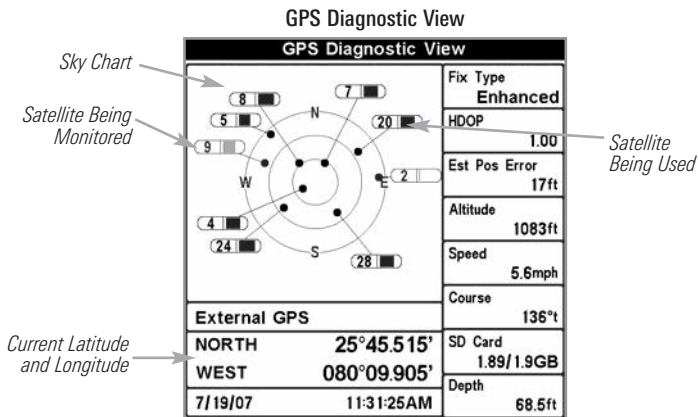

## **PC Connect** *(with PC Connect Cable only)*

---

Use **PC Connect** to update the software of the Fishing System control head. This feature requires the use of the PC Connect Cable. Complete instructions are included with the PC Connect Cable accessory.

Exit PC Connect mode by powering off the Fishing System.

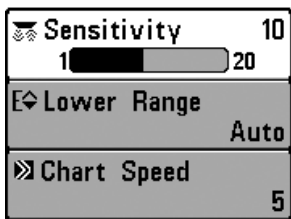

X-Press™ Menu

## X-Press™ Menu

The X-Press™ Menu provides a shortcut to your most frequently-used settings. The options provided on the X-Press™ Menu correspond with the current view. For example, if a Sonar View is displayed on the screen, and you press the MENU key once, the Sonar X-Press™ Menu will display.

### To use an X-Press™ Menu:

1. In any view, press the MENU key once to open the X-Press™ Menu.
2. Press the UP or DOWN Cursor keys to highlight an X-Press™ Menu option, then press the RIGHT or LEFT Cursor keys to change the menu setting.

***NOTE:** The X-Press™ Menu will collapse temporarily and the screen will update if it is affected by your menu setting change, which allows you to see the effects of your change immediately.*

3. Reactivate the X-Press™ Menu by pressing the UP or DOWN Cursor keys.

**Total Screen Update** - When you change any menu settings that affect the current view, the view will update immediately (i.e. you don't have to exit the menu to apply the change to the screen).

Menu options can be simplified or expanded by setting the User Mode to Normal or Advanced. See **Main Menu: User Mode** for details.

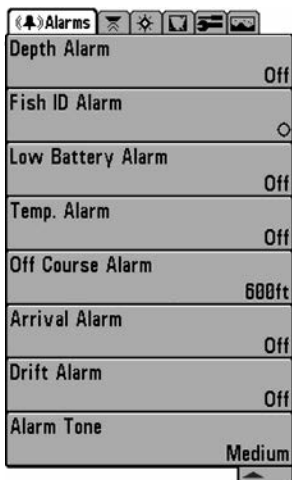

## Main Menu

The Main Menu provides the standard set of menu options, including the settings that are changed less frequently. The Main Menu is organized under the following tabs to help you find a specific menu item quickly: Alarms, Sonar, Navigation, Chart, Setup, Views, and Accessories.

*NOTE: Menu options can be expanded or simplified by setting the User Mode to Advanced or Normal. See **Main Menu: User Mode** for details.*

Main Menu, Normal User Mode

### To use the Main Menu:

1. In any view, press the MENU key twice to open the Main Menu.
2. Press the RIGHT or LEFT Cursor keys to highlight a menu tab.
3. Press the DOWN or UP Cursor keys to select a specific menu option under that tab.
4. Press the RIGHT or LEFT Cursor keys to change a menu setting.
  - A down arrow at the bottom of a menu means that you can scroll to additional menu options using the DOWN Cursor key.
  - A right or left arrow on a menu option means that you can use the RIGHT or LEFT Cursor keys to make changes or see more information.
  - Press the EXIT key to move quickly to the top of the tab.

**Total Screen Update** - When you change any menu settings that affect the current view, the view will update immediately (i.e. you don't have to exit the menu to apply the change to the screen).

## User Mode (Normal or Advanced)

---

Menu options can be simplified or expanded by setting your Fishing System User Mode to Normal or Advanced.

**Normal Mode** is provided for users who want greater simplicity and fewer menu choices.

**Advanced Mode** is provided for users who want the highest level of control over the Fishing System. Several menu settings are added to the Main Menu when the User Mode is changed to Advanced.

### To change the User Mode setting:

1. Press the MENU key twice to access the Main Menu.
2. Press the RIGHT Cursor key until the Setup tab is selected.
3. Press the DOWN Cursor key to select User Mode on the Setup main menu.
4. Press the LEFT or RIGHT Cursor keys to change the User Mode setting. (Normal or Advanced)

**NOTE:** Any changes made while in Advanced Mode will remain in effect after you switch back to Normal Mode.

*For example, the Select Readouts menu option is available when the User Mode is set to Advanced. If you change the Select Readouts settings while operating in Advanced User mode, the Select Readouts you choose will continue to display on the screen even if you switch back to Normal User Mode.*

Sonar	
Beam Select	200kHz
Surface Clutter	5
SwitchFire	Clear Mode
Fish ID +	On
Fish ID Sensitivity	5
RTS Window	Narrow
Sonar Colors	Original Palette
Bottom View	Structure ID
Zoom Width	Narrow
Transducer Select	Dual Beam
Ice Fishing Mode	Off

788ci HD  
Sonar Tab, Normal Mode

Sonar	
Beam Select	200kHz
Surface Clutter	5
SwitchFire	Clear Mode
Fish ID +	On
Fish ID Sensitivity	5
RTS Window	Narrow
Sonar Colors	Original Palette
Bottom View	Structure ID
Zoom Width	Narrow
83kHz Sensitivity	0
455kHz Sensitivity	0
Depth Lines	On
Noise Filter	Low
Max Depth	Auto
Water Type	Fresh
Transducer Select	Dual Beam
Ice Fishing Mode	Off

788ci HD  
Sonar Tab, Advanced Mode

☒ Mark	▶
⚙ Sensitivity	16
↔ Upper Range	0ft
↔ Lower Range	48ft
⏪ Chart Speed	7
🖼 Bottom View	Inverse
🔍 Zoom Level	2x
☒ Cancel Navigation	

Sonar X-Press™ Menu

## Sonar X-Press™ Menu

*(Sonar Views only)*

The **Sonar X-Press™ Menu** provides a shortcut to your most frequently-used settings. Press the MENU key once while in any of the Sonar Views to access the Sonar X-Press™ Menu.

**NOTE:** Menu options can be expanded or simplified by setting the Fishing System User Mode to Advanced or Normal. See **Main Menu: User Mode** for details.

**NOTE:** See your control head operations manual for information about the standard Sonar X-Press™ menu options.

When the Sensor is connected to the trackplotter, the Mark and Cancel Navigation menu options will be added to the Sonar X-Press™ Menu. See **Introduction to Navigation** for more information.



☒ Mark

## Mark

---

**Settings:** Press the **RIGHT Cursor** key to mark a waypoint.

**Mark** allows you to mark the position of a waypoint, either at the current boat location, or, if the Cursor is active, at the current Cursor location.

☒ Cancel Navigation

## Cancel Navigation

---

*(only when navigating)*

**Settings:** Press the **RIGHT Cursor** key and follow screen instructions.

**Cancel Navigation** discards the current route and exits Navigation Mode. This menu option will only appear when you are currently navigating a route. This will not delete a previously-saved route.



Navigation X-Press™ Menu

## Navigation X-Press™ Menu

*(Navigation Views only)*

The **Navigation X-Press™ Menu** provides a shortcut to your most frequently-used settings. Press the MENU key once while in the Bird's Eye, Chart, Track, or Combo View to access the Navigation X-Press™ Menu.

**NOTE:** Menu options will vary depending on system settings, such as whether you are currently navigating.

**NOTE:** Menu options can be expanded or simplified by setting the User Mode to Advanced or Normal. See **Main Menu: User Mode** for details.

**NOTE:** See your chartplotter operations manual for information about the standard Navigation X-Press™ menu options.

When the Sensor is connected to the trackplotter, the Navigation X-Press™ Menu will be added to the menu system. See **Introduction to Navigation** for more information.



## Mark

---

**Settings:** Press the RIGHT Cursor key to mark a waypoint.

**Mark** allows you to mark the position of a waypoint, either at the current boat location, or, if the Cursor is active, at the current Cursor location.



## Zoom

---

**Settings:** In to Out

**Zoom** allows you to change the scale of the Bird's Eye, Track, and Combo Views.

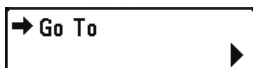

## Go To

---

**Settings:** Press the RIGHT Cursor key to activate.

**Go To** allows you to start navigation towards a waypoint. If the Cursor is active, selecting Go To creates a waypoint and starts navigation towards that waypoint. If the Cursor is not active, the list of saved waypoints will be displayed. Use the 4-WAY Cursor Control key to select a waypoint from the list and start navigation. See *Introduction to Navigation* for more information.

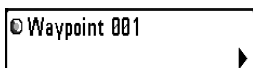

## Waypoint [Name]

---

*(only with an active cursor on a waypoint)*

**Settings:** Edit, Delete, Target, Grid

**Waypoint [Name]** allows you to view the Waypoints submenu for the waypoint under your cursor.

### The Waypoint Submenu includes the following menu options:

**Edit** allows you to edit the Name, Position (Latitude and Longitude), and select the Icon that will be used to represent the waypoint in the Track and Combo Views.

**Delete** allows you to delete a waypoint from the list of saved waypoints.

**Target** allows you to apply a target to a waypoint selected from the list of waypoints.

**Grid** allows you to apply a trolling grid to a waypoint selected from the list of waypoints.

**Cursor To Waypoint**

## Cursor to Waypoint

*(Track or Combo View only)*

**Settings:** Press the **RIGHT** Cursor key and select a waypoint from the saved waypoints list.

**Cursor to Waypoint** allows you to quickly move the cursor to any saved waypoint so that you can locate it or edit it.

***NOTE:** This X-Press™ menu option appears only if you have saved waypoints.*

**Save Current Track**

## Save Current Track

**Settings:** Press the **RIGHT** Cursor key and follow screen instructions.

**Save Current Track** allows you to save the current track on the display. After the current track is saved, a new current track is started.

***NOTE:** To save the depth information with the current track, it is important to save the track and also edit the name before powering off the control head.*

**Clear Current Track**

## Clear Current Track

**Settings:** Press the **RIGHT** Cursor key and follow screen instructions.

**Clear Current Track** allows you to clear the current track on the display and start a new track at the present position.

**Skip Next Waypoint**

## Skip Next Waypoint

*(only when navigating)*

**Settings:** Press the **RIGHT** Cursor key and follow screen instructions.

**Skip Next Waypoint** removes the next waypoint from the current route. This menu option will only appear when you are currently navigating a route.



## Cancel Navigation

*(only when navigating)*

---

**Settings:** Press the RIGHT Cursor key and follow screen instructions.

**Cancel Navigation** discards the current route and exits Navigation Mode. This menu option will only appear when you are currently navigating a route. This will not delete a previously-saved route.

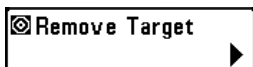

## Remove Target

*(only if a Target is active)*

---

**Settings:** Press the RIGHT Cursor key to activate.

**Remove Target** removes the waypoint target from the display. This menu option will only appear when a target has already been applied to a waypoint.

*NOTE: See Introduction to Navigation: Add a Waypoint Target or Trolling Grid for more information.*



## Remove Grid

*(only if a Grid is active)*

---

**Settings:** Press the RIGHT Cursor key to activate.

**Remove Grid** removes the waypoint grid from the display. This menu option will only appear when a grid has already been applied to a waypoint.

*NOTE: See Introduction to Navigation: Add a Waypoint Target or Trolling Grid for more information.*



## Sonar Window

*(Combo View only)*

---

**Settings:** Wide, Medium, Narrow; Default = Medium

**Sonar Window** sets the size of the Sonar Window in the Combo View. Sonar Window can only be accessed from the Combo View.

## Waypoint [Name]

(most recently-created waypoint)

Settings: Edit, Delete, Go To, Target, Grid

**Waypoint [Name]** allows you to view the waypoints submenu for the most recently-created waypoint.

***NOTE:** You must have selected MARK from the X-Press™ Menu at least once since you last powered up for this menu option to appear.*

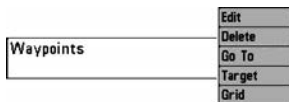

Waypoint [Name] Submenu

### The Waypoint Submenu includes the following menu options:

**Edit** allows you to edit the Name, Position (Latitude and Longitude) and select the Icon that will be used to represent the waypoint in the Track and Combo Views.

**Delete** allows you to delete a waypoint from the list of saved waypoints.

**Go To** allows you to select a waypoint and start navigation toward that waypoint, or add that waypoint to the end of the current route.

**Target** allows you to apply a target to a waypoint selected from the list of waypoints.

**Grid** allows you to apply a trolling grid to a waypoint selected from the list of waypoints.

Alarms	
Depth Alarm	Off
Fish ID Alarm	○
Low Battery Alarm	Off
Temp. Alarm	Off
Off Course Alarm	600ft
Arrival Alarm	Off
Drift Alarm	Off
Alarm Tone	Medium

Alarms Menu Tab

## Alarms Menu Tab

From any view, press the MENU key twice to access the Main Menu System. The Alarms tab will be the default selection.

**NOTE:** When an alarm is triggered, you can silence it by pressing any key. The alarm will be silenced, and it will not be triggered again until a new instance of the alarm condition is detected.

**NOTE:** Menu options can be expanded or simplified by setting the Fishing System User Mode to Advanced or Normal. See **Main Menu: User Mode** for details.

**NOTE:** See your control head operations manual for information about the standard Alarms tab menu options.

When the Sensor is connected to the trackplotter, the following menu options will be added to the Alarms tab: Off Course Alarm, Arrival Alarm, and Drift Alarm.

Off Course Alarm	300ft
Off	<input type="checkbox"/> 3000

## Off Course Alarm

Settings: Off, 25 to 3000 ft, 10 to 1000 m (International Models only); Default = 300 ft, 100 m

**Off Course Alarm** allows you to set how far the boat is allowed to move off course before the Off Course Alarm will sound during navigation.

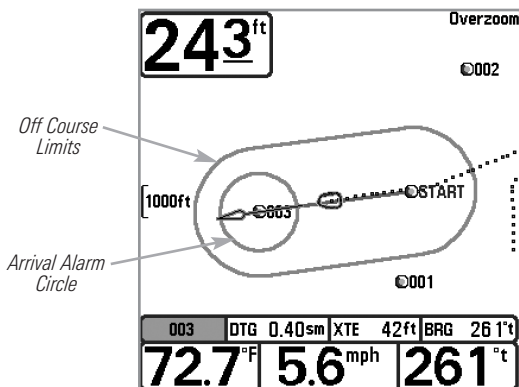

Arrival Alarm	150ft
Off	<input type="checkbox"/> 3000

## Arrival Alarm

Settings: Off, 25 to 3000 ft, 10 to 1000 m (International Models only); Default = 150 ft, 50 m

**Arrival Alarm** sounds when the boat has either exceeded the distance to the destination waypoint, or has entered the Arrival Alarm Circle, based on the menu setting when navigating. Arrival Alarm allows you to set how close the boat must be to the destination waypoint before the Arrival Alarm will sound.



Drift Alarm	Off
Off	3000

## Drift Alarm

Settings: Off, 25 to 3000 ft, 10 to 1000 m (International Models only); Default = Off

**Drift Alarm** allows you to set the size of a perimeter around the boat's anchored position. If the anchored boat drifts outside of that perimeter, the Drift Alarm will sound.

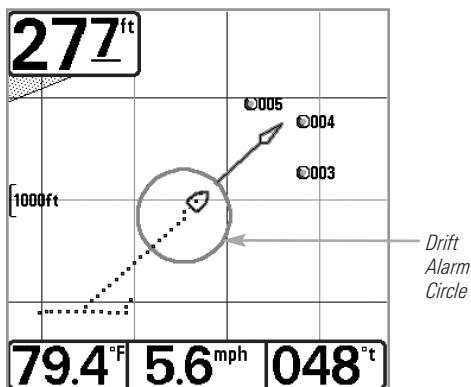

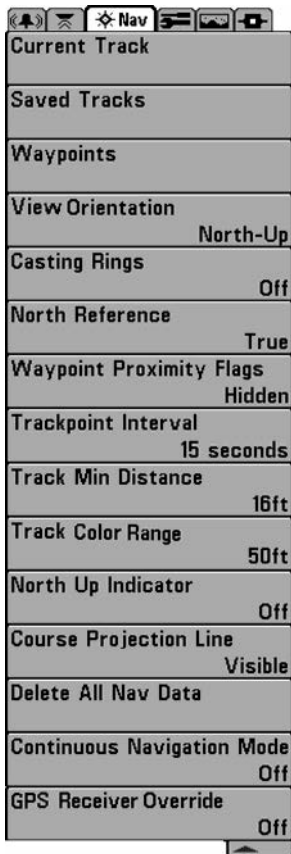

Navigation Menu Tab

## Navigation Menu Tab

Press the MENU key twice to access the Main Menu System, then press the RIGHT Cursor key to select the Navigation tab.

*NOTE: Menu options will vary depending on system settings, such as whether you are currently navigating.*

*NOTE: Menu options can be expanded or simplified by setting the User Mode to Advanced or Normal. See **Main Menu: User Mode** for details.*

*NOTE: For details about chartplotters and navigation, see your control head operations manual and the Waypoint Management Guide.*

When the Sensor is connected to the trackplotter, the Navigation tab will be added to the menu system. See *Introduction to Navigation* for more information.

Current Track	Save ▶
	Clear
	Appearance
	Stop Tracking

## Current Track

Settings: **Save, Clear, Appearance, Stop Tracking**

**Current Track** allows you to view the Current Track submenu. See *Introduction to Navigation: Edit, Delete, or Hide Saved Tracks* for more information.

### The Current Track Submenu includes the following menu options:

**Save** allows you to save the current track.

**Clear** allows you to delete the current track.

**Appearance** allows you to change the style and color of the current track (Breadcrumb Trail, Dashed Line, Solid Line or Wide Line, and if a line, the color of the line, or Color By Depth).

- If you choose **Color By Depth**, you cannot choose one color to represent the track. A color range will represent the different depths on the track instead, from light green (shallowest) to black (deepest). You can change the depth range associated with black by using the Track Color Range menu setting (see *Navigation Menu Tab: Track Color Range*).
- If you choose **Hidden**, the unit continues to save trackpoints, but the track will not be displayed on the view.

**Stop Tracking** clears the current track and the unit will not save trackpoints. To resume saving the track, select Current Track > Start Tracking.

***NOTE:** To save the depth information with the Current Track, it is important to save the track and also edit the name before powering off the control head.*



**Saved Tracks** allows you to view the Saved Tracks submenu.

The Saved Tracks Submenu includes the following menu options:

**Edit** allows you to select a previously-saved track and edit its name, whether it is visible or not, and its appearance.

**Delete** allows you to delete a track from a list of previously-saved tracks.

**Default** sets the appearance for all newly-saved tracks.



**Waypoints** allows you to view the Waypoints submenu.

The Waypoints Submenu includes the following menu options:

**Create** allows you to create a new waypoint and edit it immediately. The current boat position will be used as the default, but you can set the coordinates to any valid position. The Icon used to represent the waypoint in the Track and Combo Views can also be changed.

**Edit** allows you to choose from a list of previously-saved waypoints, then edit the Name, Position (Latitude and Longitude), and select the Icon that will be used to represent the waypoint in the Track and Combo Views.

**Delete** allows you to delete a waypoint from the list of saved waypoints.

**Cursor To** allows you to move the cursor quickly to a waypoint selected from the list of saved waypoints.

**Go To** allows you to select a waypoint and start navigation toward that waypoint, or add that waypoint to the end of the current route.

**Target** allows you to apply a target to a waypoint selected from the list of saved waypoints.

**Grid** allows you to apply a trolling grid to a waypoint selected from the list of saved waypoints.



## View Orientation

---

Settings: North-Up, Head Up, Course-Up; Default = North-Up

**View Orientation** allows you to select whether the Track and Combo Views should be drawn North-Up, Head Up, or Course-Up. The View Orientation setting does not apply to the Bird's Eye View (see *Views: View Orientation*).



## Casting Rings

---

(Advanced)

Settings: Off to 150 ft, 0 to 50 m; Default = Off

**Casting Rings** allows you to display a circle around each waypoint on the Track View. This menu option sets the distance that the Casting Ring will be displayed from the waypoint. Select Off to hide the Casting Rings.

*NOTE: Casting Rings are not applied to decluttered waypoints (see **Navigation Menu Tab: Waypoint Decluttering**).*



## North Reference

---

Settings: True, Magnetic; Default = True

**North Reference** allows you to have bearings displayed with one of two orientations: True North or Magnetic North.

## Waypoint Proximity Flags

Visible

# Waypoint Proximity Flags

(Advanced)

Settings: Hidden, Visible; Default = Hidden

**Waypoint Proximity Flags** allows you to display or hide waypoint flags for the ten closest waypoints to the boat or active cursor. The flags show the distance from the boat (or active cursor) to each waypoint.

Waypoint Proximity Flags are also influenced by the zoom level and boat speed. The flags are only displayed if the track range is less than .5 sm and the boat is traveling less than 15 mph.

### Waypoint Flags and Casting Rings Turned On

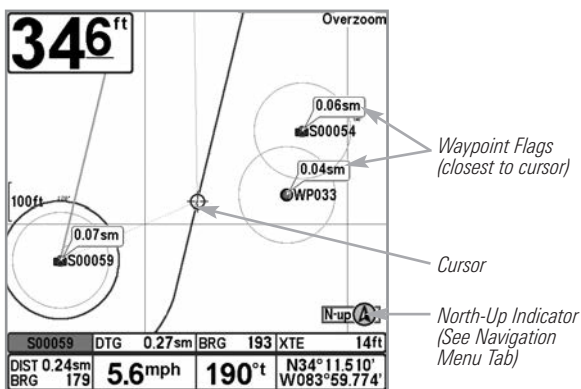

## Waypoint Decluttering

On

# Waypoint Decluttering

(Advanced)

Settings: Off, On; Default = On

**Waypoint Decluttering** allows you to set the declutter feature On or Off. When two or more waypoints overlap, or are displayed close together on a Track View, the screen will automatically declutter—waypoint names will shorten and the waypoint icons will change into small blue icons. Select Off to display waypoints at regular size.

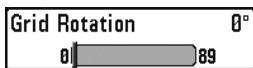

## Grid Rotation

Settings: 0° to 89°; Default = 0°

Trolling **Grid Rotation** allows you to set the orientation of the trolling grid in degrees, where a setting of 0° displays a standard North, South, East, West alignment. See *Introduction to Navigation: Add a Waypoint Target or Trolling Grid* for information.

*NOTE: This feature may appear as Trolling Grid Rotation or Grid Rotation, depending on your model.*



## Trackpoint Interval

Settings: 1 second, 5 seconds, 10 seconds, 15 seconds, 30 seconds, or 60 seconds; Default = 1 second

**Trackpoint Interval** allows you to select the time period between trackpoints. The current track can only contain up to 20,000 trackpoints, so longer time periods cause the track to extend back further in time, but will be less detailed.

Trackpoint Interval works in conjunction with Track Min Distance. Both conditions must be met before a trackpoint is added to the current track. During slow travel or drift, setting both Trackpoint Interval and Track Min Distance to small values will allow you to increase the track resolution.



## Track Min Distance

(Advanced)

Settings: 1 to 300 ft, or 1 to 100 m (International Models only); Default = 16 ft, 5 m

**Track Min Distance** allows you to set a minimum distance of travel before a trackpoint is added to the track.

Track Min Distance works in conjunction with Trackpoint Interval. Both conditions must be met before a trackpoint is added to the current track. During slow travel or drift, setting both Trackpoint Interval and Track Min Distance to small values will allow you to increase the track resolution.

### Track Color Range

50  3000

## Track Color Range

---

Settings: 50 to 3000 feet or 20 to 1000 meters (International Models only); Default = 50 ft, 20 m

**Track Color Range** allows you to set the depth range that will be displayed as black, the deepest depth, when Color By Depth is selected as the style for the current track (see *Navigation Menu Tab: Current Track*).

### Map Datum

WGS 84 (Default)

## Map Datum

---

(Advanced)

Settings: Various, Default = WGS 84

**Map Datum** allows you to change the map coordinate system used by the Fishing System to match those of a paper map.

### North Up Indicator

On

## North-Up Indicator

---

Settings: On, Off; Default = Off

**North-Up Indicator** allows you to display the North-Up icon on the screen to indicate the direction of True North. The North-Up Indicator displays the View Orientation and will change as the orientation and data source change. See *Navigation Menu Tab and Views: View Orientation*.

### Course Projection Line

Visible

## Course Projection Line

---

Settings: Standard, Single Vector, COG/SOG; Default = Standard

**Course Projection Line** displays an arrow or line, extending from the bow of the boat, that projects your current course and shows where the boat will go if you continue on your present course.

You can choose the style of the Course Projection Line as follows:

- **Standard** = arrow
- **Single Vector** = line
- **COG/SOG** = line with tick marks at set intervals from the boat. The tick marks are based on the speed calculation.





## Heading Offset

*(Advanced, Heading Sensors only)*

---

Settings:  $-30^{\circ}$  to  $+30^{\circ}$ ; Default = 0

Use **Heading Offset** to rotate the zero point of the Heading Sensor. For more information, see *Confirm the Heading Sensor Operation* in the Installation section of this manual.

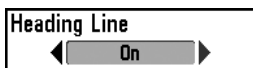

## Heading Line

*(Advanced, Heading Sensors only)*

---

Settings: On, Off; Default = Off

**Heading Line** allows you to display or hide the heading line. When it is turned on, the heading line extends from the bow of the boat icon on-screen.

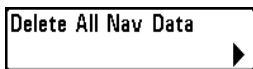

## Delete All Nav Data

*(Advanced)*

---

Settings: Press the **RIGHT** Cursor key and follow screen instructions.

This menu option should be used with caution!

**Delete All Nav Data** allows you to delete all saved Tracks and Waypoints.



## Continuous Navigation Mode

Settings: Off, On; Default = Off

---

**Continuous Navigation Mode** allows you to continue to navigate and fish around a particular waypoint even if you pass over it multiple times.

## GPS Receiver Override

Auto

# GPS Receiver Override

*(Advanced)*

---

**Settings:** Internal, External, Auto; Default = Auto

**GPS Receiver Override** allows you to set which GPS receiver to use if you have multiple GPS receivers plugged into the system. These multiple GPS receivers may be internal, external, or connected via the InterLink™. If you select Auto, your unit will select a GPS receiver automatically.

**NOTE:** *If only one GPS receiver is plugged into your system, then Auto will be the only option shown.*

Setup	
Units - Depth	Feet
Units - Temp	°F
Units - Distance	Statute Miles
Units - Speed	mph
User Mode	Advanced
Language	English
Triplog Reset	
Restore Defaults	
Select Readouts	
Depth Offset	0.0ft
Temp. Offset	0.0°
Speed Calibration	0%
Local Time Zone	EST (UTC-5)
Daylight Saving Time	Off
Position Format	dd°mm.mmm'
Time Format	12-Hour
Date Format	mm/dd/yy
Digits Format	Small Tenths
NMEA Output	Off

Setup Menu Tab

## Setup Menu Tab

From any view, press the MENU key twice to access the tabbed Main Menu, then press the RIGHT Cursor key until the Setup tab is selected.

*NOTE: Menu options will vary depending on which accessories are attached to the unit.*

*NOTE: Menu options can be expanded or simplified by setting the User Mode to Advanced or Normal. See **Main Menu: User Mode** for details.*

*NOTE: See your control head operations manual for information about the standard Setup tab menu options.*

**When the Sensor is connected to the trackplotter**, the following menu options will be added to the Setup tab:

- Units - Distance
- Units - Speed
- Triplog Reset
- Select Readouts: Additional digital readouts will be available.
- Local Time Zone (Advanced)
- Daylight Saving Time (Advanced)
- Position Format (Advanced)
- Time Format (Advanced, International Only)
- Date Format (Advanced, International Only)
- NMEA Output

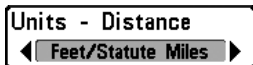

## Units - Distance

---

Domestic Models: Statute Miles, Nautical Miles, Default = Statute Miles; International Models: Meters/Kilometers, Meters/Nautical Miles, Feet/Statute Miles, Feet/Nautical Miles, Default = Meters/Kilometers

**Units - Distance** selects the units of measure for all distance-related readouts.

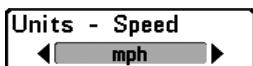

## Units - Speed

---

Domestic Models: mph, kts; International Models: kph, mph, kts; Default = mph/kph

**Units - Speed** selects the units of measure for speed-related readouts.

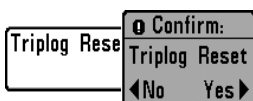

## Triplog Reset

---

Settings: Press the RIGHT Cursor key and follow screen instructions to activate.

**Triplog Reset** resets the Triplog to zero. The Triplog provides the following information: timer for elapsed time, distance traveled since last reset, and average speed.

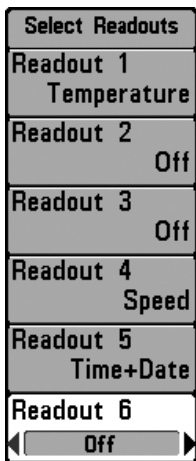

Select Readouts

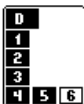

*The readout position on the screen is shown in the Select Readouts Window.*

## Select Readouts

*(Advanced, Sonar View only)*

Settings: Various, Default = Off

**Select Readouts** allows you to select the information that will be displayed in each data window of the Sonar View. To leave the data window blank, select Off.

Data windows display readouts from connected equipment. When the Sensor is connected to the trackplotter, the following digital readouts will be available:

- Course
- Navigation
- Position
- Speed
- TTG (Time to Go to the next Waypoint)
- Heading  
(Heading Sensors only)
- Pitch and Roll  
(Heading Sensors only)
- Temperature
- Time
- Time + Date
- Timer
- Triplog
- Voltage

The location and availability of the digital readouts vary by model. Some views have fixed readouts. Also the digital readouts may change with the selected view, attached accessories, and whether or not the control head is navigating. See your control head operations manual for details.

## Sonar View with Digital Readouts (1198c SI)

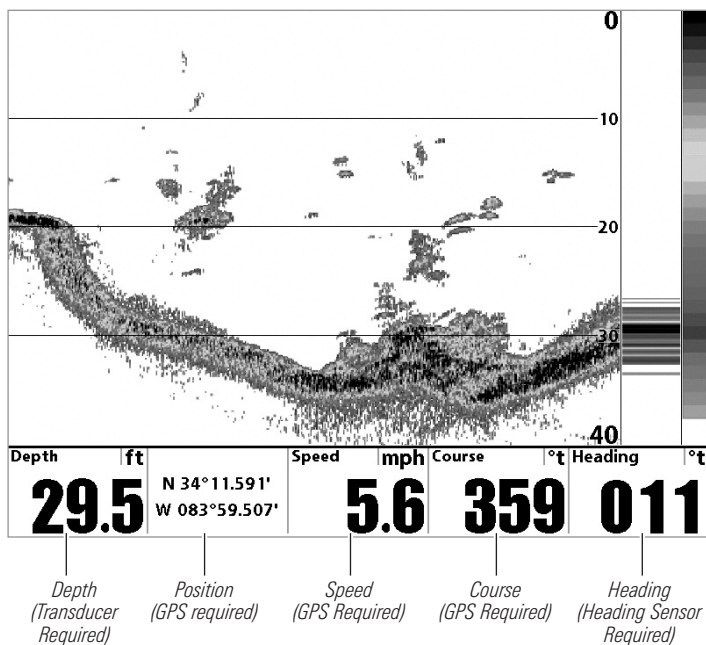

## Local Time Zone

(Advanced)

Settings: Various, Default = EST [UTC-5] - Eastern Standard Time

**Local Time Zone** selects your time zone in reference to the time reported by the GPS receiver when Time + Date is selected as a Digital Readout on the Sonar View (see *Setup Menu Tab: Select Readouts*).

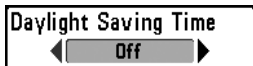

## Daylight Saving Time

(Advanced)

---

Settings: Off, On; Default = Off

**Daylight Saving Time** adjusts the time display to account for local Daylight Saving Time when Time + Date is selected as a Digital Readout on the Sonar View (see *Setup Menu Tab: Select Readouts*).

Selecting On adds one hour to the time display adjusted for your local time zone. Selecting Off leaves the time display as adjusted for your local time zone.



## Position Format

(Advanced)

---

Settings: dd.ddddd°, dd°mm.mmm', or dd°mm'ss";  
Default = dd°mm.mmm'

**Position Format** selects the format of the latitude and longitude position display.



## Time Format

(Advanced, International only)

---

Settings: 12 hour, 24 hour; Default = 12 hour

**Time Format** changes the time format used by the unit. Time Format selects a 12 hour or 24 hour format for the time of day displayed when Time + Date is selected as a Digital Readout on the Sonar View (see *Setup Menu Tab: Select Readouts*).



## Date Format

(Advanced, International only)

---

Settings: mm/dd/yy, dd.mm.yy, yy.mm.dd;  
Default = mm/dd/yy

**Date Format** changes the date format used by the unit. Date Format selects the format for the date display when Time + Date is selected as a Digital Readout on the Sonar View (see *Setup Menu Tab: Select Readouts*).

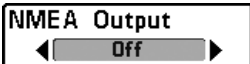

## NMEA Output

(Advanced)

---

**Settings: Off, On; Default = Off**

**NMEA Output** turns the NMEA\* output on or off. NMEA Output should be turned On if you connect the NMEA Output wires of the GPS receiver cable to another NMEA-compatible device, such as an autopilot.

*\*NMEA 0183 is a National Marine Electronics Association standard for data communication.*

**NOTE:** A separate purchase of accessory AS-HHGPS may be required for the NMEA output function.

**NOTE:** The menu option in your Fishing System will be called NMEA 0183 Output or NMEA Output.

### The following NMEA sentences are output when NMEA Output is turned On:

DPT- Depth

MTW - Water Temperature

GLL - Lat/Lon Position

GGA - GPS Fix Data

HDG - Heading, Deviation, and Variation (Heading Sensors only)

HDM - Heading, Magnetic (Heading Sensors only)

RMC - Recommended Minimum Specific GNSS Data

VTG - Course Over Ground and Ground Speed

ZDA - Time and Date

### When navigating, the following NMEA sentences are also output when NMEA Output is turned On:

APB - Autopilot Sentence B

BWR - Bearing and Distance to Waypoint

HDG - Heading, Deviation, and Variation (Heading Sensors only)

HDM - Heading, Magnetic (Heading Sensors only)

RMB - Recommended Minimum Navigation Info



# Troubleshooting

---

Before contacting the Humminbird® Customer Resource Center, please read the following section. Taking the time to review these troubleshooting guidelines may allow you to solve a performance problem yourself, and therefore avoid sending your unit back for repair.

## Fishing System Doesn't Power Up

---

If your Fishing System doesn't power up, use the Installation Guide that also comes with it for specific confirmation details, making sure that:

- the power cable is properly connected to the Fishing System control head,
- the power cable is wired correctly, with red to positive battery terminal and black to negative terminal or ground,
- the fuse is operational, and
- the battery voltage of the power connector is at least 10 Volts.

Correct any known problems, including removing corrosion from the battery terminals or wiring, or actually replacing the battery if necessary.

## Fishing System Defaults to Simulator with a Transducer Attached

---

A connected and functioning transducer will cause the newly-started Fishing System to go into Normal operating mode automatically. If, when you power up the Fishing System, it goes into Simulator mode automatically, even though a transducer is already connected, this means that the control head is not detecting the transducer. Perform the following troubleshooting tasks:

- Using the Installation Guide that also comes with your Fishing System, check to make sure that the transducer cable is securely connected to the Fishing System. Reconnect if necessary, and power up the Fishing System again to see if this fixes the problem.
- Replace the non-functioning transducer with a known good transducer if available and power up the control head again.
- Check the transducer cable. Replace the transducer if the cable is damaged or corroded.

## Display Problems

---

There are several main conditions or sources of possible interference that may cause problems with the quality of the information displayed on the control head. Look in the following table for some symptoms of display problems and possible solutions:

Problem	Possible Cause
<b>The control head loses power at high speeds.</b>	If the power output of your boat's engine is unregulated, the control head may be protecting itself using its over-voltage protection feature. Make sure the input voltage does not exceed 20 Volts.
<b>When the boat moves at higher speeds, the bottom disappears or suddenly weakens, or the display contains gaps.</b>	<p>The transducer position may need to be adjusted. A mix of air and water flowing around the transducer (cavitation) may be interfering with the interpretation of sonar data. See your Installation Guide for suggestions on adjusting the transducer position.</p> <p>Electrical noise from the boat's engine may be interfering with sonar reception. See <i>Finding the Cause of Noise</i> for more information.</p>
<b>There are no fish detected, even when you know they are in the water under the boat, or sonar readings seem weak or faulty.</b>	<p>Sonar readings may be affected if the transducer is not positioned correctly (i.e. mounted at an angle, not straight down), or there is some kind of mechanical interference, either because it is mounted inside a hull that is too thick for proper sonar transmission, the bond between the transducer and the hull is not airtight, or because the transducer is dirty. Check with your Installation Guide for guidance on re-positioning the transducer, and make sure the transducer is clean.</p> <p>Low battery voltage may be affecting the power of signal transmission.</p> <p>Electrical noise from the boat's engine may be interfering with sonar reception. See <i>Finding the Cause of Noise</i> for more information.</p>

## Finding the Cause of Noise

---

Electrical noise usually affects the display with many black dots at high speeds, and high sensitivity readings. One or more of the following sources can cause noise or interference:

---

### Possible Source of Noise

### Isolation

---

#### Other electronic devices

Turn off any nearby electronic devices to see if the problem goes away, then turn them on one at a time to see if the noise re-appears.

#### The boat's engine

To determine whether the boat's engine is the source of the noise, increase the RPMs while the boat is in neutral and stationary to see if the noise increases proportionately; if noise appears when you rev the engine, the problem could be the spark plugs, alternator, or tachometer wiring. Replace the spark plugs with resistor plugs, install an alternator filter, or route the control head power and transducer cables away from the engine wiring.

#### Cavitation from the boat's propeller

Turbulence created by the propeller can cause noise; make sure the transducer is mounted at least 15" (38 cm) from the propeller, and that the water flows smoothly over the face of the transducer at all times.

## GPS & Navigation Glossary

---

**Acquisition Time** The length of time that a GPS receiver typically takes to determine a position from at least three satellites. Humminbird® GPS receivers provide very fast acquisition times (under one minute), permitting users to get out on the water faster.

**Altitude** The height measurement above sea level. Altitude is a measurement that can be provided by GPS.

**Bearing (BRG)** The direction to a destination waypoint measured in degrees from North (i.e. 321°, where 000° is North, 090° East, 180° is South, 270° is West).

**Chartplotter** A navigation device that shows Present Position on a Map, along with Tracks, Waypoints, and Routes. All Chartplotters are also considered Trackplotters.

**Cold Start** The procedure that a GPS receiver must perform when it does not have historical information regarding its current location. This procedure typically lasts for several minutes, and may be experienced upon first power up of the receiver, or if the receiver has been moved a great distance.

**Course Over Ground (COG)** The current direction the boat is traveling measured in degrees from North (i.e. 321°, where 000° is North, 090° East, 180° is South, 270° is West). When the Course Over Ground is equal to Bearing, the boat is said to be “On Course” and will arrive at the destination in the most efficient manner. COG is often confused with Heading. See *Heading*.

**Cross Track Error (XTE)** The straight-line distance of the boat from the intended Track. XTE measures how far the boat is off course and also triggers the Off Course Alarm. See *Track*.

**Differential GPS (DGPS)** A system used to improve the position accuracy of the Department of Defense GPS through the use of secondary “correction signals” broadcast from ground stations around the coastal United States and on some inland waterways. These correction signals are provided by the USCG and received by an auxiliary Differential Beacon Receiver (DBR) that connects to the GPS receiver. The advent of WAAS has largely negated the need for the added expense of a DBR in the United States.

**Distance To Go** The straight-line distance between Present Position and the Destination Waypoint. DTG and SOG (Speed Over Ground) are used to calculate Time To Go. See *Time to Go* and *Speed Over Ground*.

**Estimated Position Error (EPE)** A calculation that indicates the potential position inaccuracy the user may experience due to a variety of GPS factors which include satellite position in the sky, signal strength, and others factors.

**Fix Type** Indicates whether the GPS receiver is providing 2D fix or 3D fix. A 2D fix requires only three satellites and provides only latitude and longitude. A 3D fix requires four or more satellites, and provides latitude, longitude, and altitude.

**GPS (Global Positioning System)** GPS provides accurate position (latitude, longitude, altitude) information virtually anywhere on the earth through satellite technology and personal receivers on the ground. See *How GPS Works*.

**Heading** The direction the boat is pointing and is measured in degrees (i.e. 321°, where 000° is North, 090° East, 180° is South, 270° is West). Due to wind and waves, the boat is often traveling in a slightly different direction than it is heading, and therefore Heading is often confused with Course Over Ground. See *Course Over Ground*.

**Map Datum** Refers to a particular survey of the earth's surface that was referenced when creating a chart (i.e. WGS84). It is important to select the correct Map Datum setting in your fishfinder when comparing GPS position to a paper chart to avoid slight position inaccuracies. Almost all electronic charts use the WGS84 Map Datum and therefore, they do not require setting changes.

**MMC (Multi Media Card)** An MMC is a postage stamp-sized memory device used to store electronic data such a maps, waypoints, routes, and other information. MMC is a very rugged format suitable for the marine environment, but it is not waterproof. MMC is the same format that many digital cameras use. See *SD*.

**North, Magnetic** The principle reference point of the compass (i.e. North is 000°). Magnetic North relies on the earth's magnetic field to align a metal pointer generally towards True North. However, due to local variations in the earth's magnetic field around the globe, the difference between True North and Magnetic North can be greater than 10°. See *True North*.

**North, True** The principle reference point of the compass (i.e. North is 000°). True North uses the axis of the rotation of the earth as the reference for North and is constant for all points on the earth. Most GPS units default to True North as the setting. The GPS heading may vary from the boat compass heading because the compass uses Magnetic North. See *Magnetic North*.

**Present Position** The current location (latitude, longitude) determined by GPS. The Present Position is indicated on-screen by a directional boat icon if the boat is moving or a round symbol if the boat is stationary.

**Route** A series of waypoints linked together in a specific sequence to define a navigation path between two points, and saved in the fishfinder's memory. Routes are often used when frequently traveling between two or more locations because it is a faster and more accurate method than repeatedly selecting individual waypoints each time one travels through the same area. Routes consist of a Start Waypoint, an End Waypoint, and a series of waypoints in between. Users can begin navigation at the beginning, the end (to run the route in reverse) or at any waypoint in between. See *Waypoint*.

**SD (Secure Digital)** An SD card is virtually identical in function to an MMC; however, the speed at which information can be accessed is generally faster, the storage capacity is generally larger, and the card has security features which can be used to prevent extracting the data from the card. SD is the same format that many digital cameras use. See *MMC*.

**Selective Availability (SA)** A GPS system "feature" that can be implemented by the U.S. Department of Defense (DoD) to degrade the accuracy of GPS positioning information. With SA active, the GPS is accurate to within 100 meters 95% of the time. With SA inactive, the GPS is accurate to within 45 meters 95% of the time. Currently, SA is inactive and the consumer can enjoy the greater precision GPS provides; however, the DoD reserves the right to activate SA at any time.

**Speed Over Ground (SOG)** The measurement of the boat's progress across a given distance and the speed measurement provided by GPS. An alternate, Speed Through Water, is provided by a speed paddlewheel, and is the measurement of the flow past the boat, which may vary depending on current speed and direction. Speed Over Ground is optimal for navigation because accurate destination times can be derived from this measurement. Humminbird® products allow for input and display of both speed measurements.

**Time To Go (TTG)** The estimated time required to reach the destination waypoint. TTG is calculated using the SOG and DTG. See *SOG* and *DTG*.

**Track** A series of saved points that define the past path of the boat. These Track Points are saved at regular time intervals. Tracks are a useful and quick method to see where you've been, and an easy guide to follow to get you back to the starting point. Generally, all GPS units have a limited number of Track Points that can be saved before the unit runs

out of memory and begins erasing the first track points saved. Because of this, the user can adjust the Track Point Interval menu to increase the amount of time between when points are saved, and thus extend the distance covered by a track. Tracks can also be permanently saved to memory and re-displayed at the user's option.

**Track Line (TRK)** The planned line of travel between two waypoints, and it represents the most efficient path between the two points because it is a straight line. The TRK is measured in degrees (i.e. 321°, where 000° is North, 090° East, 180° is South, 270° is West). See *Cross Track Error* and *Course Over Ground*.

**Trackplotter** A navigation device that shows Present Position, along with Track, Waypoint, and Routes, but NO MAP in the background. See *Chartplotter*.

**Trolling Grid** A Humminbird® feature that displays a precise reference grid around a waypoint. This grid is used as a guide pattern for trolling around a specific area to assure a more efficient and complete coverage of that area.

**UTC (Universal Time Constant)** UTC is the “standard time” used in navigation and is the local time in Greenwich England. (UTC is equivalent to Greenwich Mean Time (GMT)).

**WAAS (Wide Area Augmentation System)** WAAS is complementary technology to GPS that provides enhanced accuracy through correction signals broadcast from Federal Aviation Administration WAAS satellites stationed over the USA. These secondary signals are automatically received by the standard Humminbird® GPS Receiver. With WAAS signal, GPS accuracy is improved to within 3 meters 95% of the time. Outside the United States, regional governmental coalitions have created similar systems such as EGNOS (Europe) and MSAS (Japan).

**Waypoint** The saved location (latitude, longitude) of a point of interest that is stored in a GPS receiver's memory. This can include a marker buoy, dock, fishing hole, or anywhere else the user may want to return to. Humminbird® products offer the ability to name and assign a symbol to the saved location. Depth, Date, and Time of Day when the waypoint was created is also saved.

**Waypoint Target** A Humminbird® feature that displays a precise “bull's eye” around a selected waypoint. This bull's eye is used to easily monitor boat position relative to a waypoint, and is useful for fishing over submerged structure. With Waypoint Targets, a quick look at the screen lets you know how far off the waypoint the boat has drifted.