

Sport Sway Bar Kit 22835
91-99 BMW E36 M3

Installation of Hotchkis Front Sway Bar

1F *Raising Vehicle*

Raise front of the vehicle by using a 4 post lift or drive-on ramps. Securely block the rear wheels of the vehicle. You do not have to remove the front wheels

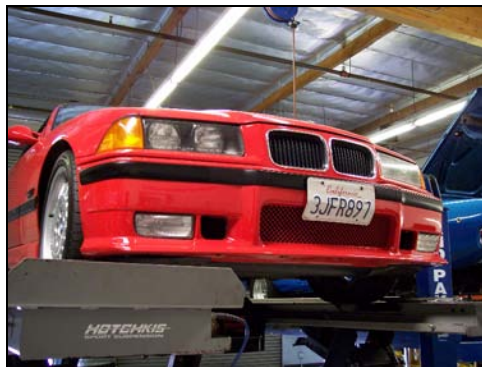

2F *Remove OE Front Bar*

- a) Disconnect the sway bar end links from the sway bar ends.
- b) Undo the bushing brackets by unfastening the 2 nuts for each bracket
- c) Bar should be loose from the vehicle. Note the OE orientation for reference.

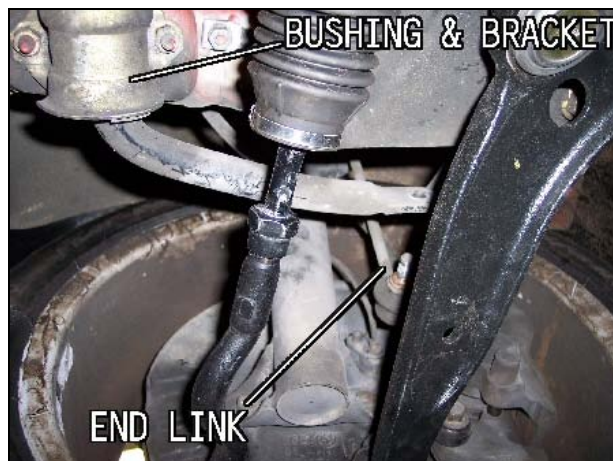

3F *Reinstall the Hotchkis Front Bar*

Reinstall the Hotchkis Front sway bar in the same manner as removal. The Hotchkis front kit comes with new polyurethane bushings, bushing brackets and bushing spacer plates. The bushing spacer plates are used to create a flat surface for the new bushing to sit on properly.

INSERT SPACER BETWEEN BUSHING
AND CAR MOUNTING POINT

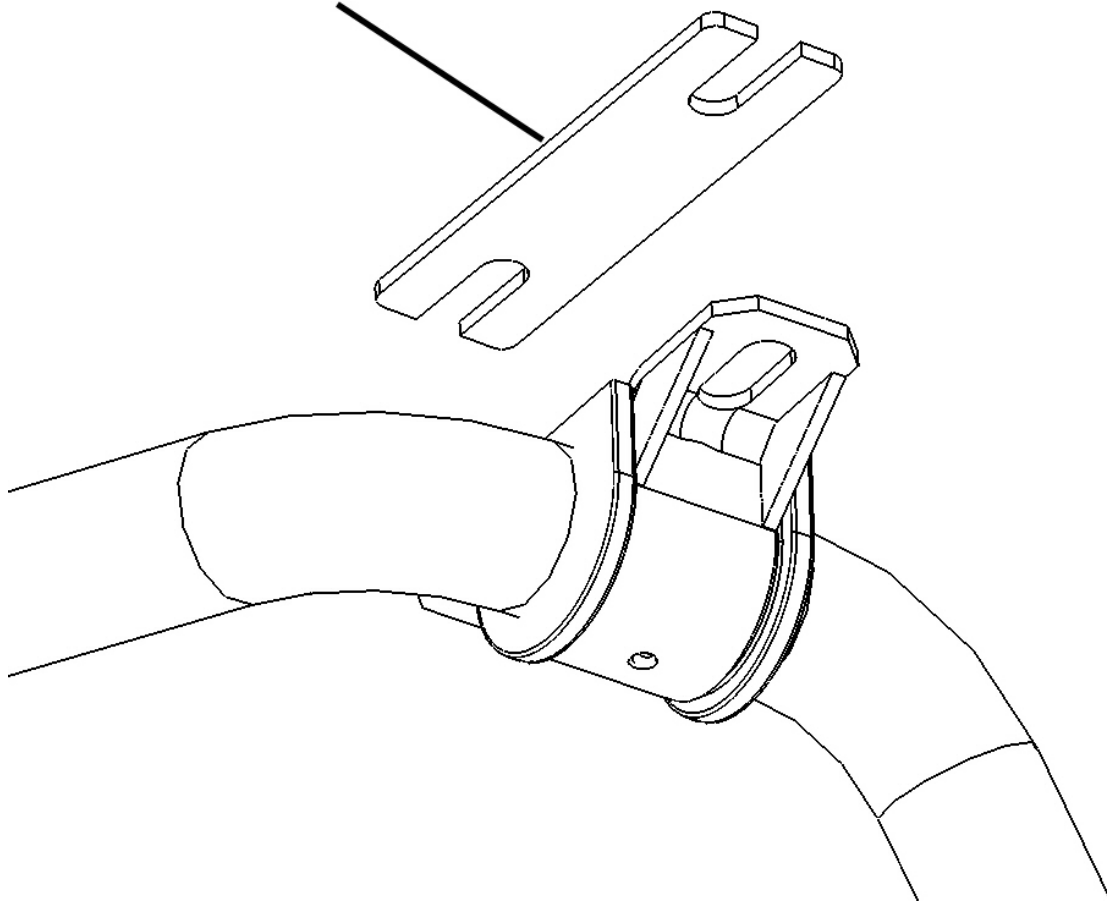

Fully tighten all hardware and you are done with the front bar.

4F *Sway Bar Stiffness*

300% Stiffer than Stock (hole near the end)

380% Stiffer than Stock (2nd hole)

If you would like to upgrade your front end links to our Fully Adjustable End Links, please order our kit #**25828F**

Installation of Hotchkis Rear Sway Bar

1R *Raising Vehicle*

Raise rear of the vehicle by using a 4 post lift or drive-on ramps. Securely block the front wheels. You do not have to remove the rear wheels.

2R *Remove Stock Bar*

- a) Disconnect the sway bar end link clevis mount from the upper control arm
- b) Undo the bushing brackets by unfastening the 2 bolts for each bracket
- c) Undo the rear exhaust hangers to gain more clearance.
- d) Bar should be loose from the vehicle. Note the OE orientation for reference.



3R *Remove the OE End Link Clevis Mount*

Your new Hotchkis kit includes new end links and hardware; however you will need to reuse the OE end link clevis mount.



4R *Assemble New End Links*

With the new end links off the old bar, install the clevis brackets onto the Hotchkis end link as shown below. You will need to also reuse the OE bolt and nut. Fully tighten this hardware. Do not tighten the jam nut on the link itself just yet.



5R *Install the End Link Assembly*

Install the end link assembly back onto the upper control arm.



6R *Install the Bushing Mount Reinforcement Bracket*

Due to the weak design of the BMW bushing mount, extra reinforcement is required. Your kit includes reinforcement brackets that attach to the subframe bolts.

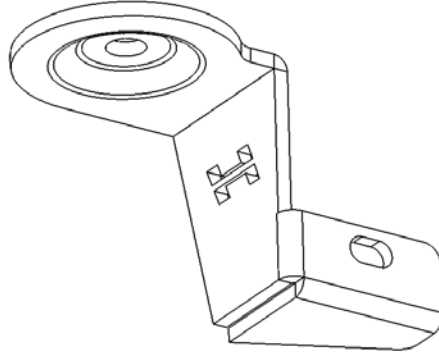

Undo the rearward subframe bolt (one at a time). You may discard the large washer. Install the correct side bracket onto the bolt and fasten it back into place.

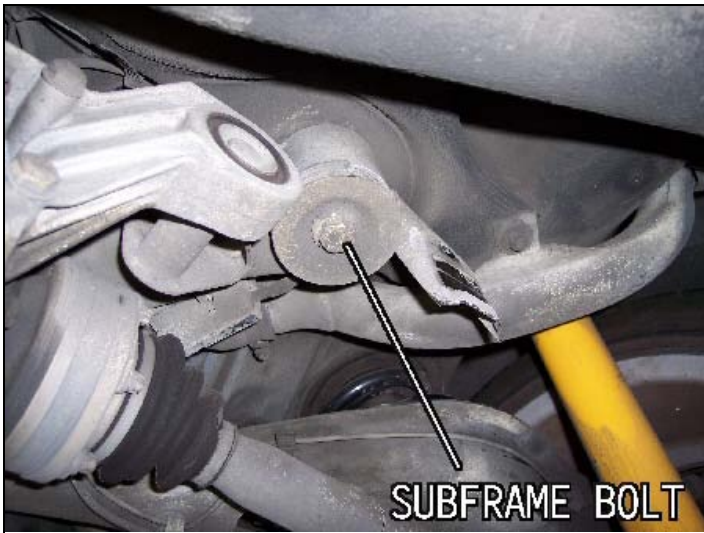

7R *Position the Sway Bar*

Insert and position the sway bar in the same manner as stock removal.



8R *Install the Bushings*

Grease the inner surface of the bushings with the supplied lube. Open the bushing at the split and install onto the sway bar.



9R *Position Bushing Bracket*

Push on the bushing bracket onto the 2 bushings. Do not fasten any hardware at this time.



10R *Insert Spacer Shim*

When we installed the reinforcement bracket on the vehicle, the mounting surface of the original mount and the reinforcement bracket do not match. We provide a spacer shim to take up the difference. Insert the shim as shown below. There is one shim per side.



11R *Install Bushing Bracket Hardware*

Install the bushing bracket hardware included in your kit. The bushing brackets have slots in them so you will notice that the bar can be shifted up or down slightly. Shift the bar up and tighten the bar at this position. If the bracket is positioned too low, it may come in contact with the exhaust pipes.



12R *Securing End Links to Sway Bar*

Before you attach your end links to the sway bar, we must first adjust the height for the end links. Since your ride height may be different than other E36's, end link adjustment will be mandatory. Rotate your sway bar into position so that the holes on the end match the hole in the end link; note the gap between the bar & the axle and the bar & the lower control arm. Thread the end link body in or out to adjust the length of the end link. Try to make the gaps above and below the sway bar to be the same.





Once the gaps are equalized, grease the end link bushings and fully tighten the hardware including the jam nut that fastens the heim joint to the end link body.

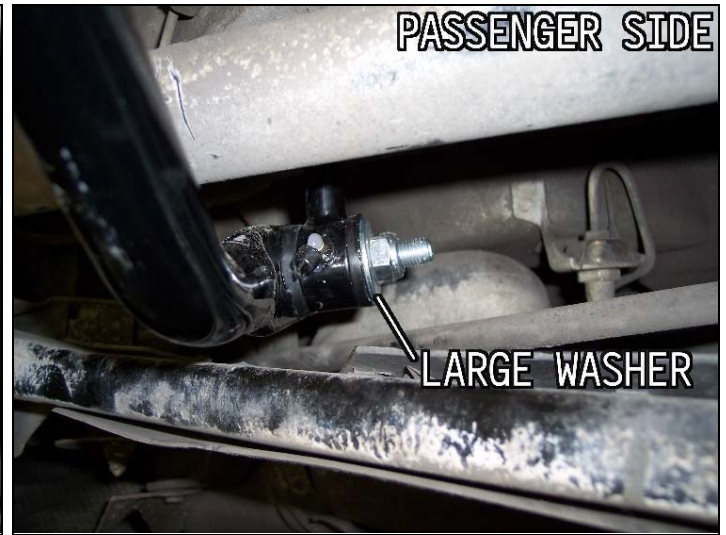

13R *Finish Up*

Re-attach the exhaust and make sure everything else is fully tightened.



14R *Stiffness Adjustment*

Your Hotchkis rear bar has 2 adjustment holes, which allow the customer to change the sway bar stiffness harder or softer. The hole closest to the sway bar end is the softer setting, while the hole furthest from the end is the stiffest. The stiffness increase compared the stock bar is as follows:

Soft Setting: 115% Stiffer than Stock

Stiff Setting: 140% Stiffer than Stock