

HOTCHKIS

HOTCHKIS

SPORT SUSPENSION

2282

1964-1972 GM A Body

Extreme Sway Bar Kit

Before You Start:

Please read this entire instruction manual before starting. Being prepared with the right tools and procedures will aid in the ease of this installation.

This sway bar kit requires Hotchkis Trailing Arms (p/n 1302) to be installed beforehand. You will not be able to install this kit using stock trailing arms due to end link interference.

Front Bar Installation

1. Look carefully at the current installation.
2. This installation can be performed without removing the front wheels . Always use proper safety devices such as jack stands or lift jacks to properly support the vehicle.
3. Loosen front bushing retaining bolts, leave a few threads engaged to support the bar.
4. Remove the factory end link from the car.
5. Support or hold the center of bar and carefully remove front bushing bolts.
6. Remove factory bar from vehicle, taking note of the placement of the swaybar bushings.

7. Using the included white silicone grease, grease the inside of the urethane 1 7/16" in sway bar bushings. (The silicone grease can be cleaned up with WD40.)



8. Install the urethane bushings on the bar. Make sure you position the bushing so when the bar is installed in the vehicle, the split will face the front of the car.
9. Place the bushing's bracket over top the bushing.



10. Install the new swaybar into the car using the included Cap Screws on the new brackets. This step will take some manipulating, as the original car was designed for a very small sway bar. You will need a 1/4" or a 6mm Allen Driver Socket for this. Our swaybar set is a much larger diameter than stock bar, and our Heavy Duty sway bar bushings and brackets are larger as well. You might find it easier to slightly squeeze the brackets together in a vice to allow you to better align the bracket holes with the original factory holes. Using a ratchet or air impact, install the screws with a washer under each head. This does work very well, you just need to use some torque to install these bolts. Have patience with this step.

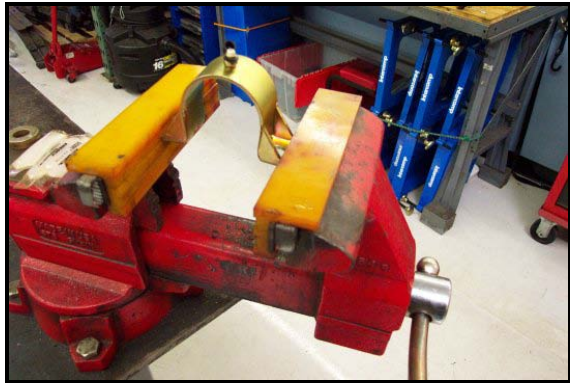

11. Install the new A-Arm endlinks using a ratchet and wrench.
12. Tighten end link nut to the point where the end link bushing's diameter is just larger than it's support washer.



Rear Bar Installation

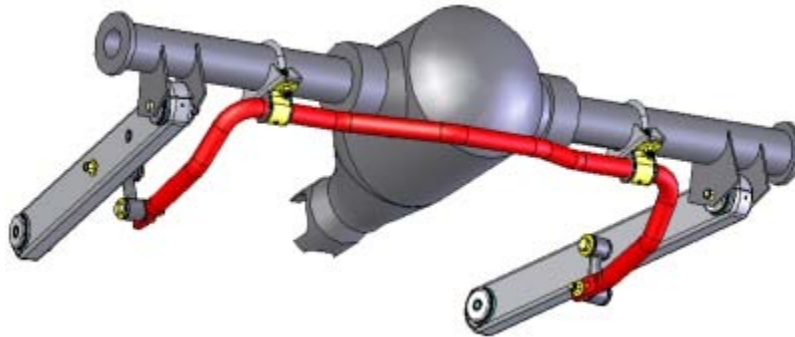

Before You Start:

This sway bar kit requires Hotchkis Trailing Arms (p/n 1302) to be installed beforehand. You will not be able to install this kit using stock trailing arms due to end link interference.

1. Raise Rear of the Vehicle

To properly install the rear sway bar you must have the rear suspension at ride height. Please use a 4-post lift or alignment rack to raise the vehicle. If these are not available, you may use floor ramps to gain access to the underside of the vehicle. Floor ramps can be found at most local auto parts stores.

2. Install Hotchkis End Links

Lube the polyurethane bushing surface on both dogbone end links. Look at your dogbone and notice that the bushing sleeves on each end have different inner diameters. The trailing arm bolt will use the small sleeve and the sway bar bolt will use the large hole. Use the 7/16" x 4" bolt to attach the end link to the trailing arm. The bolt should be pointing inboard. Use the 7/16" SAE washer (small) on the bolt head side and the 7/16" USS washer (larger) on the nut side. Do not fully tighten at this time.



3. Attach Sway Bar to the End Links

Orient the sway bar so that the Hotchkis sticker is right side up. At this time you can choose the stiffness setting by using the hole at the end for a softer setting or the 2nd hole from the end for a harder setting. Use the 1/2" x 3" bolt to attach the sway bar to the end link. The bolt should be pointing inboard. Use the 1/2" SAE washer (small) on the bolt head side and the 1/2" USS washer (larger) on the nut side. Do not fully tighten at this time.



4. Install Axle Brackets

First step is to install the provided stainless steel U-bolts. Each U-bolt will install a little inboard of the spring mount. You will have to unclip the brake line from the axle tab and carefully pull the brake line away from the axle tube to give enough clearance for the U-bolts.



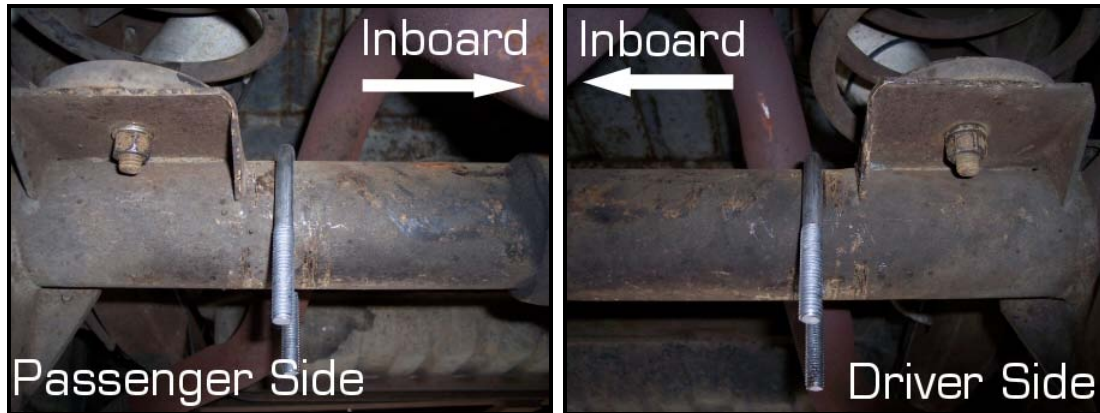

Next, apply the provided lube on the inside surface of the polyurethane bushings. Pop the bushings onto the sway bar. Slide the bushing brackets onto the bushings.



Apply a small amount of anti-seize to the threads of the U-bolts. Next position the axle bracket up against the axle tube. Raise the sway bar up to meet the axle bracket and allow the U-bolts to poke through the bushing bracket. Fasten the assembly together with the provided nut and washer. Do not fully tighten.



5. Position the Sway Bar

Since all of the hardware is still semi-loose, we can position the sway bar so that the end links are perpendicular to the trailing arm. Once the bar is positioned, fully tighten the axle bracket U-bolts. Then fully tighten the rest of the hardware. You are finished with this installation.

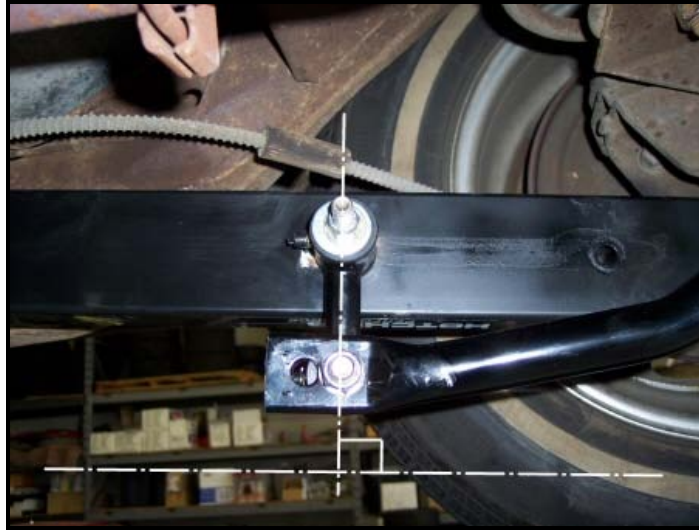

6. Optional Reinforcement

If the vehicle is going to be drag racing or road racing, it is recommended that you weld the axle brackets to the axle tubes. Sand off the paint on the mating edge of the axle bracket and axle tube. MIG weld a few beads on each side of the bracket. Finish it off with a little spray paint to keep it from rusting.