

Sport Sway Bar Kit 2254 *70-74 Chrysler E-Body 'Cuda, Challenger*



IMPORTANT: PLEASE READ THE ENTIRE INSTRUCTION MANUAL BEFORE STARTING THIS INSTALLATION. THERE'S SOME HOLE DRILLING INVOLVED AND IT WOULD BE A SHAME TO MAKE ANY UNNECESSARY HOLES DUE TO INSTALLER ERROR. METAL GRINDING IS ALSO NECESSARY.

Installation of Hotchkis Front Sway Bar

- 1F. Raise the Vehicle*
Raise the vehicle and safely secure it on jack stands. Remove either the driver or passenger side wheel.
- 2F. Disconnect End Links*
Disconnect the stock sway bar end links from the lower control arm and the sway bar
- 3F. Disconnect Bushing Brackets*
Disconnect the bushing bracket from the subframe bushing mounts.
- 4F. Remove Subframe Bushing Mounts.*
Unbolt the 2 nuts and remove the subframe bushing mounts.

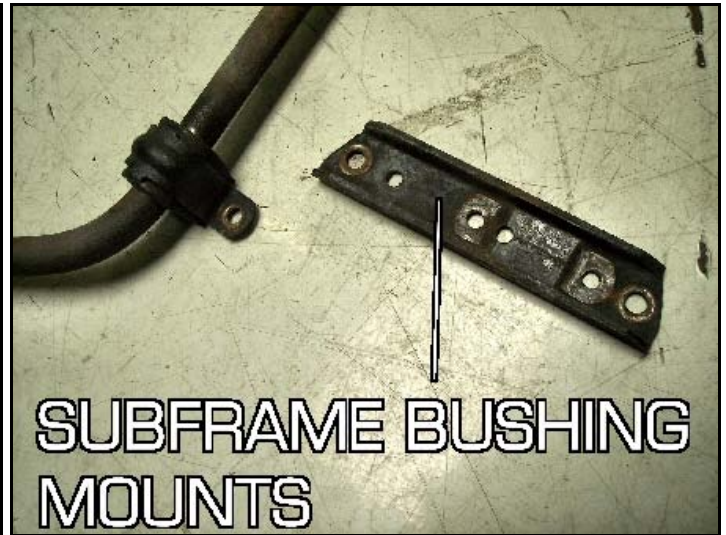
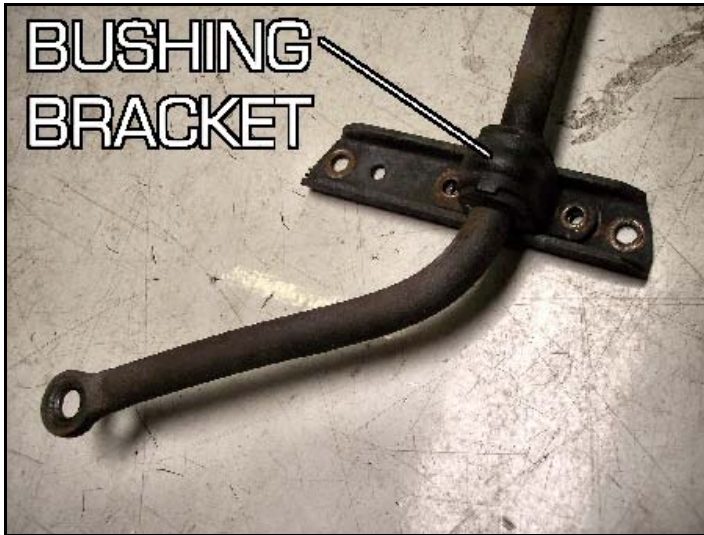

5F. Remove the Front Stock Sway Bar

Fish the stock bar towards the side that the wheel was taken off. The stock sway bar should be able to be completely removed from the vehicle.

6F. Disconnect the Radiator Bracket

There is a radiator bracket directly in front of the k-frame. Disconnect the rearward bolt and loosen the front bolt to swing the bracket out of the way.



7F. Cut Skid Plate

If your k-frame has a skid plate you will need to cut the front welds that attach the plate to the k-frame. This will allow you to carefully bend the skid plate downward to allow the new bar to go in. Use a cut-off wheel or grinder to cut the welds. You will be re-bending and rewelding the plate back to it's original position later in this installation.



8F. Install Hotchkis Sway Bar

Insert the Hotchkis front sway bar through the middle of the k-frame like the stock bar use to.

9F. Install New Subframe Bushing Mounts

Install the Hotchkis subframe bushing mounts with the included hardware. Use the fine thread 3/8 hex bolts for this mount. Make sure to use a washer for the bolt head and the nut side.



10F *Install the Bushings & Brackets*

Lube the inside surface of the new bushings with the provided grease. Install the bushings on to the bar. Install the bushing bracket onto the bushing. Due to tolerances in subframes, you may need to install one or two 1/8" spacers between the bushing and the subframe bushing mounts. Please check the clearance the bar has inside the k-member. If it needs to move up or down, use add or remove the spacers to achieve proper clearance. Use the provided 3/8 socket head bolts and nuts. These are coarse thread. Use the flat cut washers on the socket head side and insert the bolts from the bottom

SUBFRAME BUSHING MOUNT

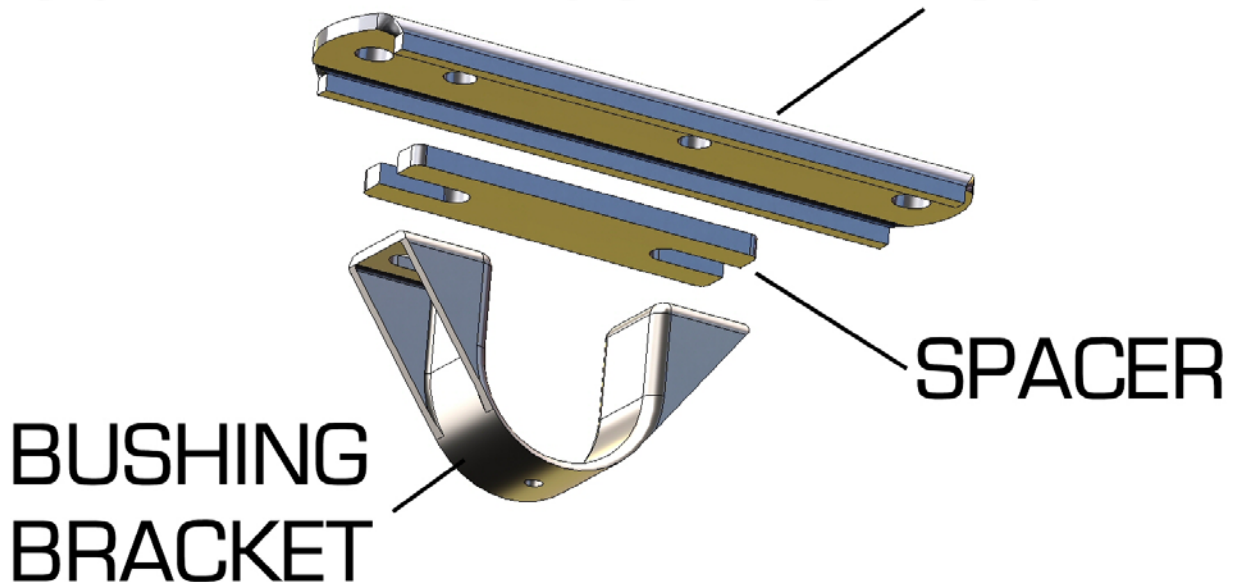

11F. *Install End Links*

Install the new end links in the same fashion as the stock removal.



12F *Re-Weld Skid Plate*

Use a jack to push the skid plate back to its original position. Sand or grind down the area near the cut. Disconnect the car battery and re-weld the plate.

13F *Sway Bar Stiffness*

This bar is 220% stiffer than stock.



Installation of Hotchkis Rear Sway Bar

1R. Raise the Vehicle, Remove Rear Bar

Installation must be done at ride height. Drive vehicle on to ramps, or use a 4-post alignment style rack. If your vehicle has a factory sway bar, jack up the vehicle and support with jack stands, remove one wheel, remove end links and bushing brackets, and slide bar out side of vehicle. Install wheel, and lower vehicle back down to ride height.



2R. Install Axle Brackets

Hang the bushing bracket u-bolts over the axle tubes.

3R. Install Bushings & Brackets

Apply grease to the new bushings with the supplied grease, install onto sway bar, and press bushing brackets over bushings.

4R. Attach bar to Axle

Lift the sway bar into position, and attach to u-bolts with the axle brackets. Install the nuts onto the u-bolts, but do not completely tighten yet. Align the axle brackets so they are level with the ground.

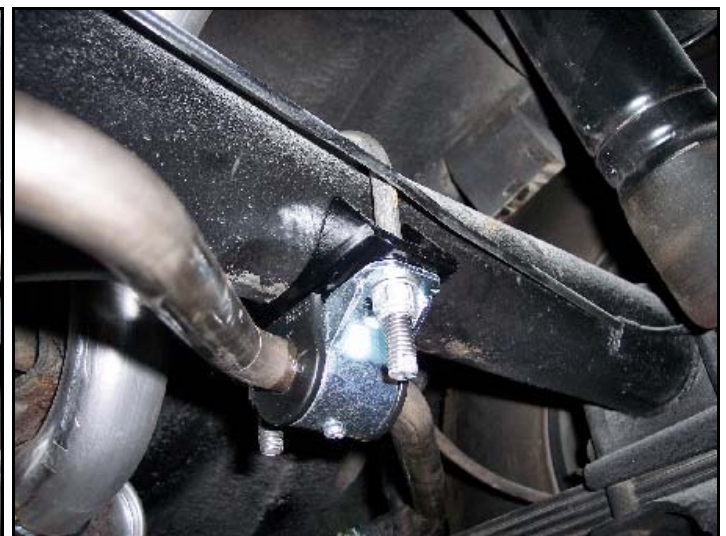
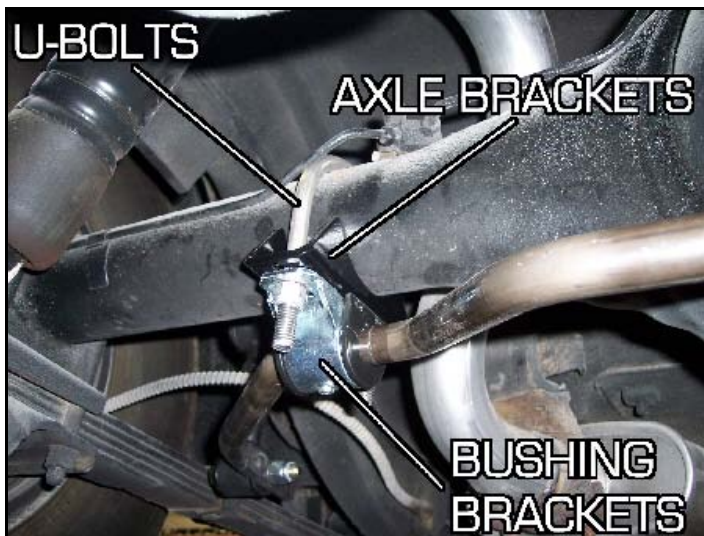

- 5R. *Install End Link Dog Bones & Frame Bracket for Mock Fit*
Install dog-bones and triangle frame brackets onto sway bar with the supplied hardware in the center hole of the sway bar.



We've noticed on some E-bodies that the distance between the left and right frame rails were $\frac{1}{2}$ " wider. If the frame bracket does not line up in the center of each frame rail due to the frames having a wider span, then please install the optional spacer between the sway bar and the end link.



6R. *Mock Up Reinforcement Frame Brackets*

Since the vehicles frame rails are made out of thin steel, it is necessary to reinforce the frame rails in the area that the sway bar mounts to. There are 2 brackets that are included in your kit (one per side).

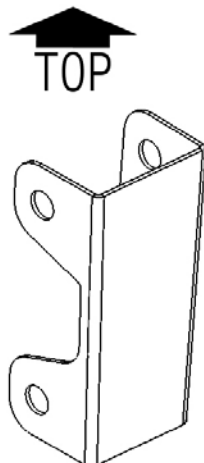

REINFORCEMENT BRACKET

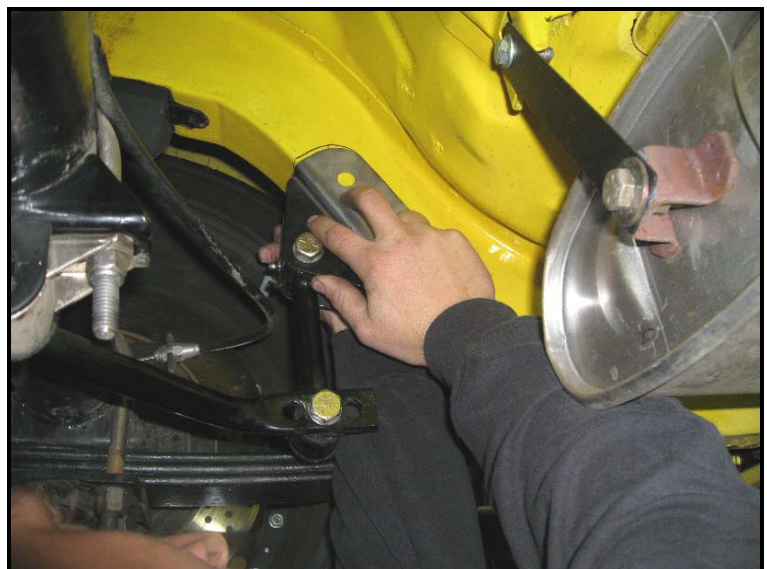

Place the reinforcement bracket onto the frame rail and position the sway bar triangle frame bracket up against the reinforcement bracket. Mark the frame rails outlining the entire bracket including the side holes. Do this for both sides.

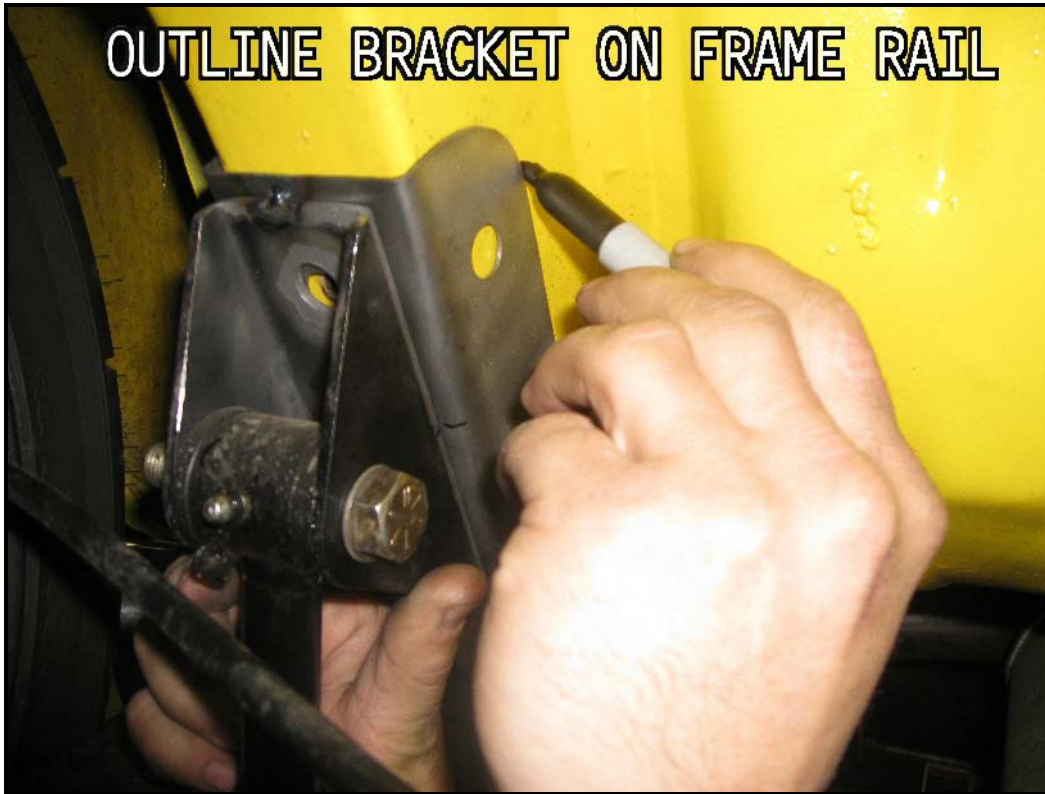

With the brackets in position, mark the hole position of the triangle bracket onto the reinforcement bracket.

MARK HOLES ON
REINFORCEMENT
BRACKET

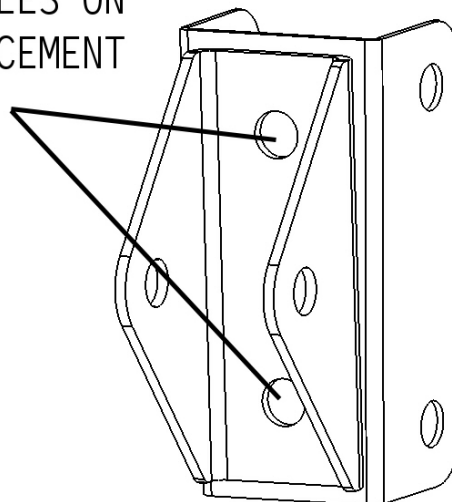

7R. Clean Area for Welding

Raise the rear of the vehicle and remove the rear wheels. This will allow you to access the outer section of the frame rails easier. Sand the paint off the frame rails near the outline of the bracket.



Sand the frame triangle bracket in the sections showed below.

SAND PAINT OFF

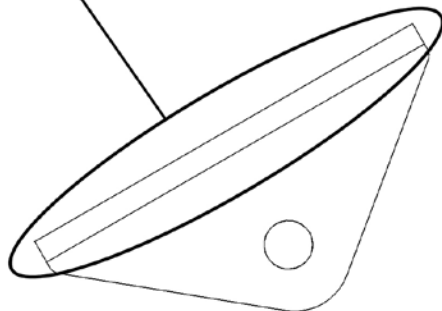

SAND PAINT OFF

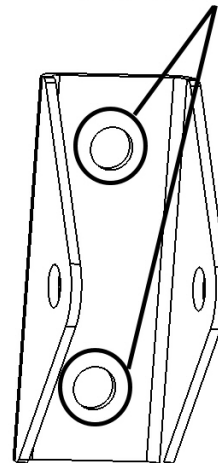

8R. Weld Triangle Bracket to the Reinforcement Bracket

C-Clamp the triangle frame bracket to the reinforcement bracket and rosette weld the 2 holes you marked at the end of step 6R. Once the brackets are together, weld a bead along the

side edges of the triangle bracket and the reinforcement bracket. Do this for both driver and passenger sides.

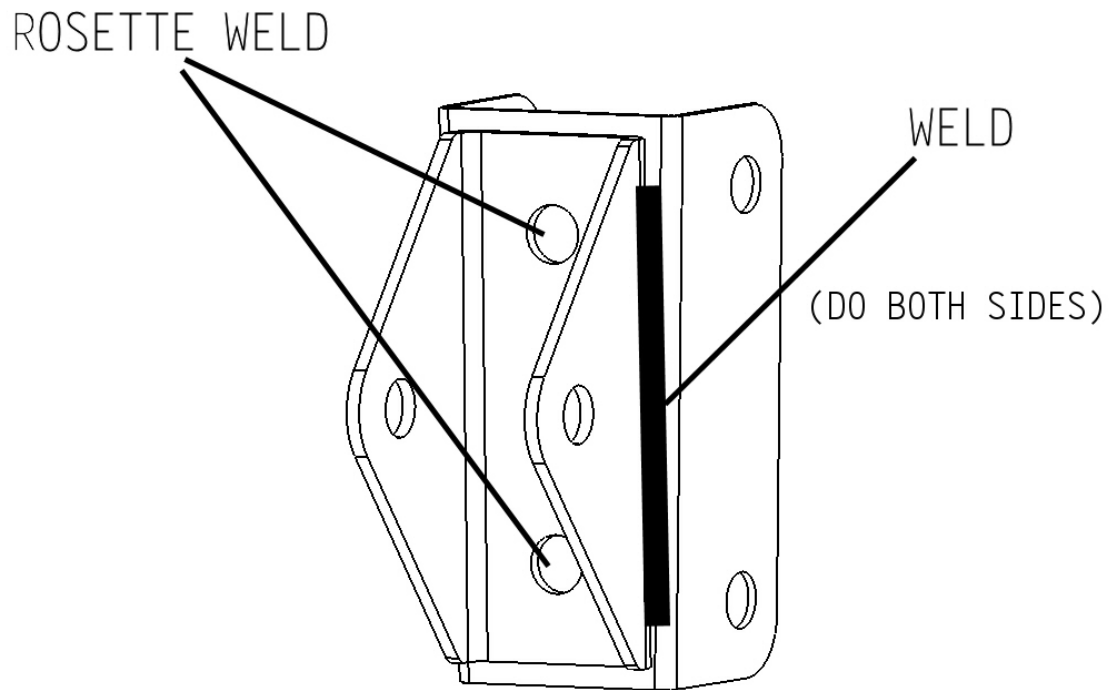

9R. *Weld Reinforcement Brackets to Frame Rails*

With the triangle bracket and reinforcement brackets welded together, slide the reinforcement bracket onto the frame rail. C-clamp it into place. Use the "positioning line" made in step 7R to get the assembly into the correct position.



Weld the bracket to the frame rail as shown below.

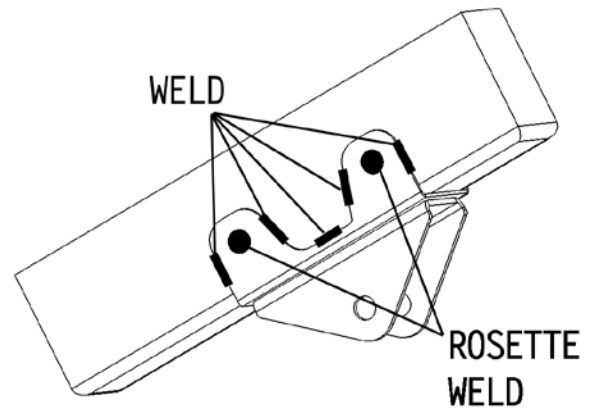
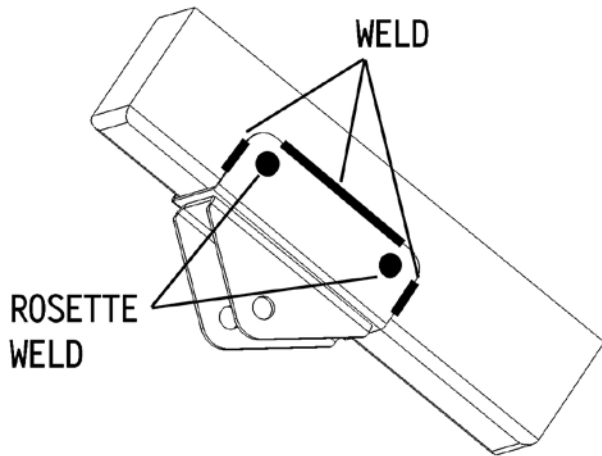

10R *Paint & Reassemble End Links*

Once the brackets are welded in place, paint the exposed metal with your choice of color. Reinstall the end links onto the triangle brackets and fully tighten all hardware. You are finished!

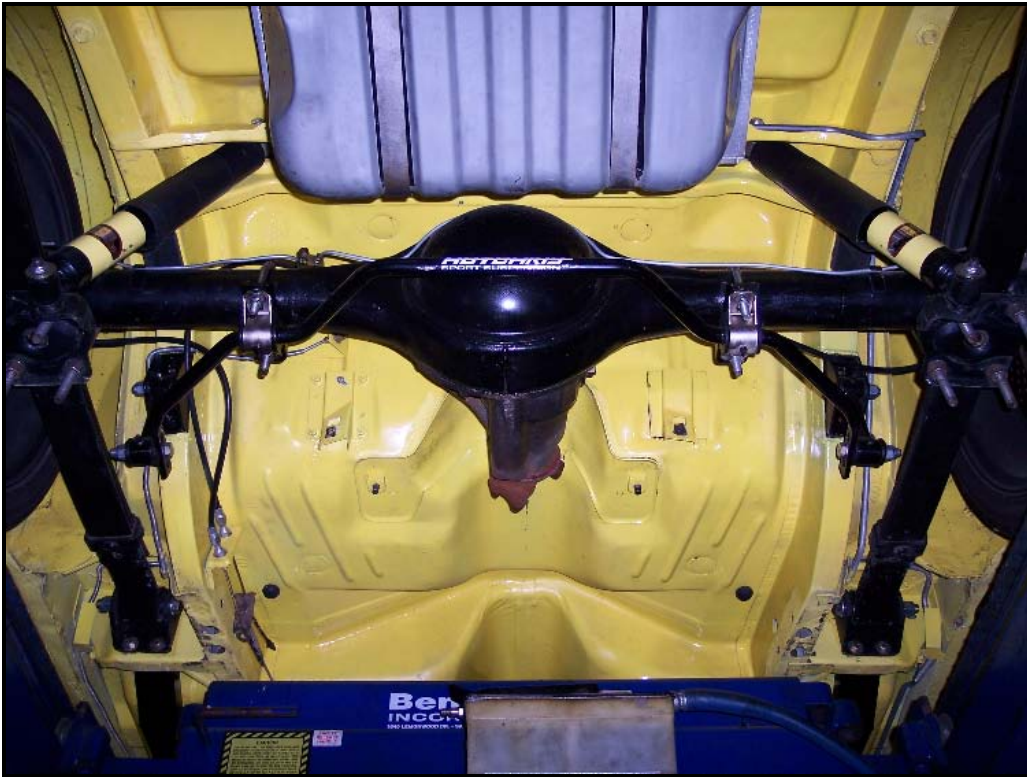

11R *Offset Leaf Springs Owners!*

If you have installed a 1-1.5" offset leaf spring kit prior or after the installation of the Hotchkis sway bar set, you may have an interference issue between the leaf spring and the dog bone attachment at the sway bar end. You can gain more clearance by installing our studded dog bone conversion kit 17366.

