

## *Sport Sway Bar Kit 22385* *67-72 Chrysler A-Body*

IMPORTANT: PLEASE READ THE ENTIRE INSTRUCTION MANUAL BEFORE STARTING THIS INSTALLATION.

### Front Sway Bar Installation

- 1F Lift the vehicle and support. Wheels must be at ride height for end link, and bushing bracket mock-up, use of a flat alignment style rack, or drive-up ramps preferred.



- 2F Clean all grease, dirt, or debris from front face of the lower control arm in preparation for welding on end-link brackets. Brackets are to be mounted level, and approx. 1/8" inboard of the strut rods (Hotchkis). Only tack weld in brackets at this time.

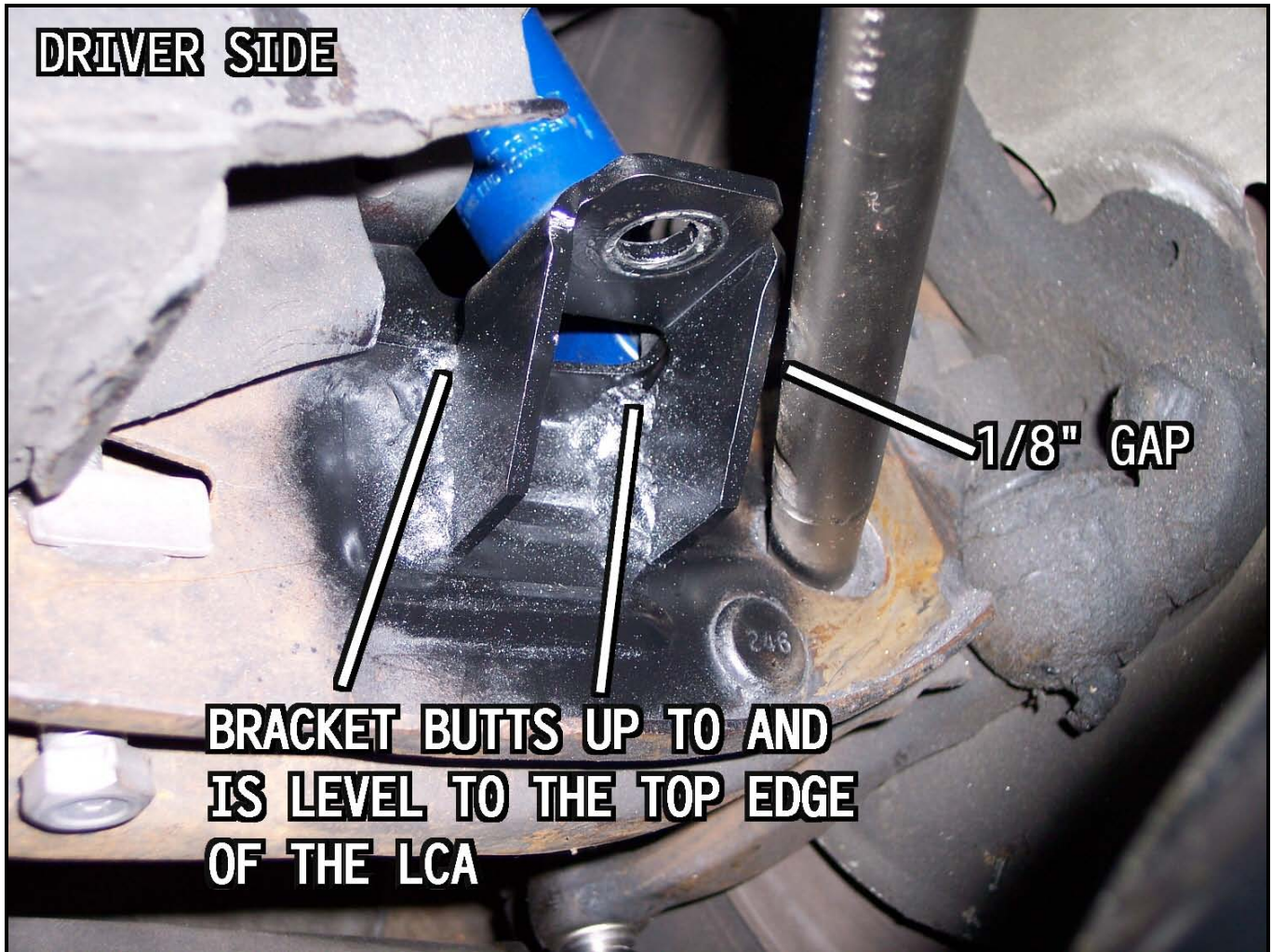



- 3F Attach sway bar end-links to the bar, LCA brackets, lift front of sway bar towards the frame, and support. (radiator support brace may need to be removed for clearance.) Verify that the end-links are vertical, and that the span between the end-link brackets match the width of the sway bar. (Uneven distance may be caused by worn, or damaged lower control arm bushings.) If modifications, adjustments, or repairs need to be made, perform them at this time before continuing with the installation. Replacement lower control arm bushings are available from Hotchkis (part #21366).



- 4F With end links attached, loosely install the sway bar bushings, brackets, and frame mounts to the inboard side of the sway bar centering rings. Lift sway bar, and position brackets and frame mounts evenly side to side, as well as fore & aft, to keep end links vertical. Clean and prep the surface of frame, and tack weld into position. See following steps.

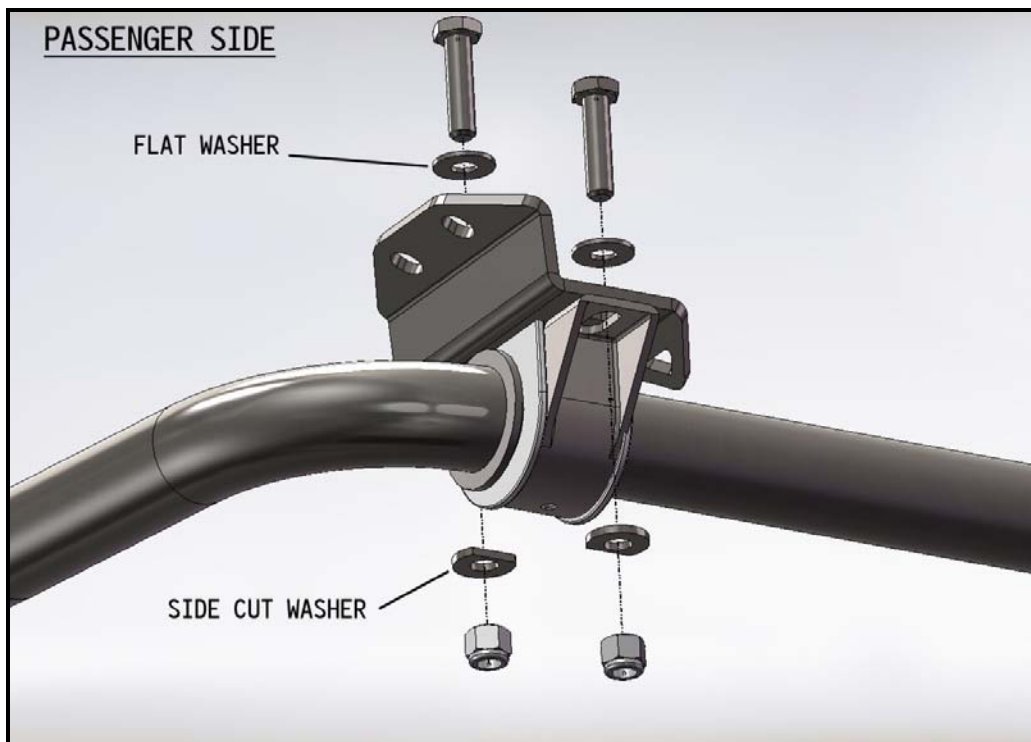

Position the entire assembly up to the K-member. The bracket should mate up to the k-member as shown below.

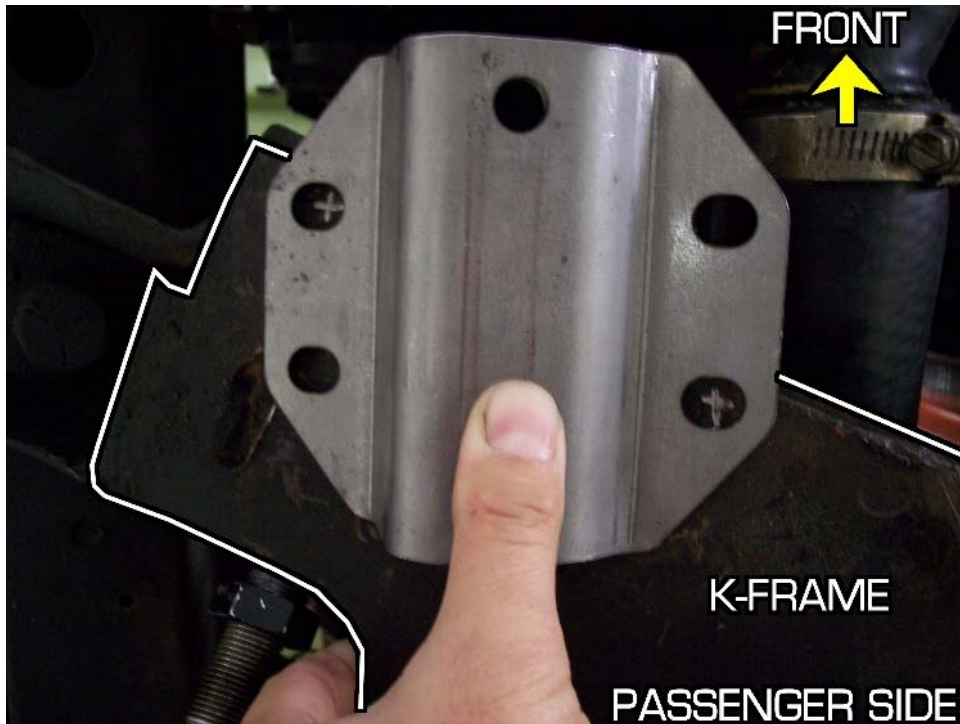

*(Picture shows bushings, brackets, & bar removed for clarity purposes.)*

Use a paint marker to mark where the holes are as well as the outer edges that mate with the k-frame. (Picture shows bracket disconnected from the sway bar for clarity purposes.)

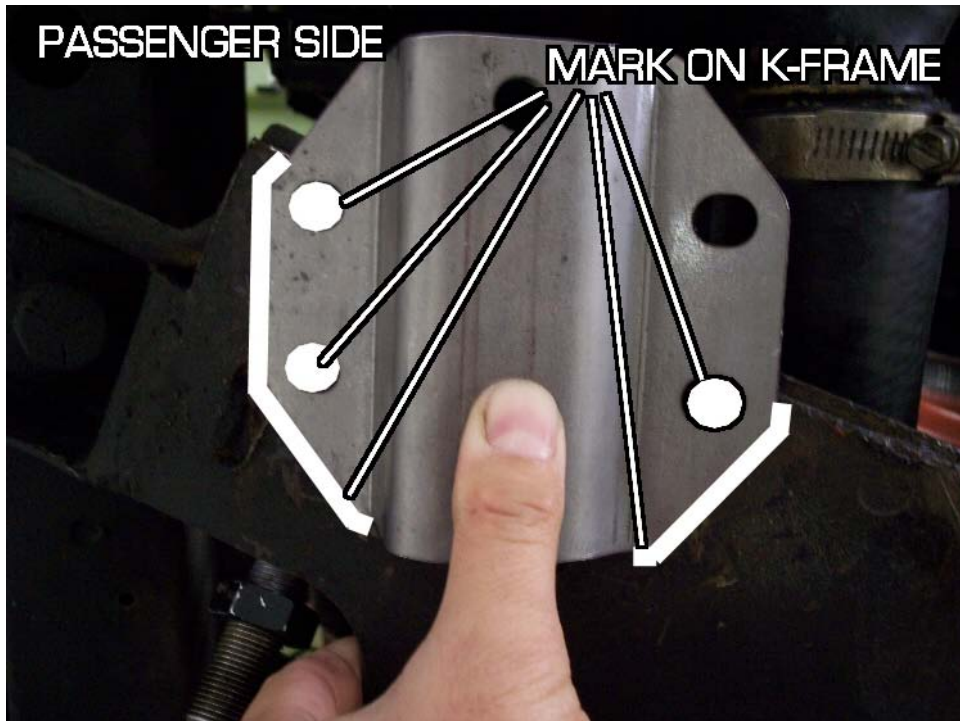

Once the k-frame is marked, use an angle grinder with a sand paper attachment to remove all of the paint and grime on the areas previously marked. What we are doing is cleaning the area that is going to be welded.

Reposition the bar back onto the k-frame so the mounting bracket is sitting flush with the k-frame. A jack does a good job of holding the bar in place for you. You will now weld the bracket to the k-frame. The best way to start is to tack weld a couple of spots around the bracket. Once the brackets are secure, unbolt the D-shaped bushing bracket and end links to get the bar out of the way. Finish welding a bead as shown in the picture below. Also weld up the holes creating a rosette weld.

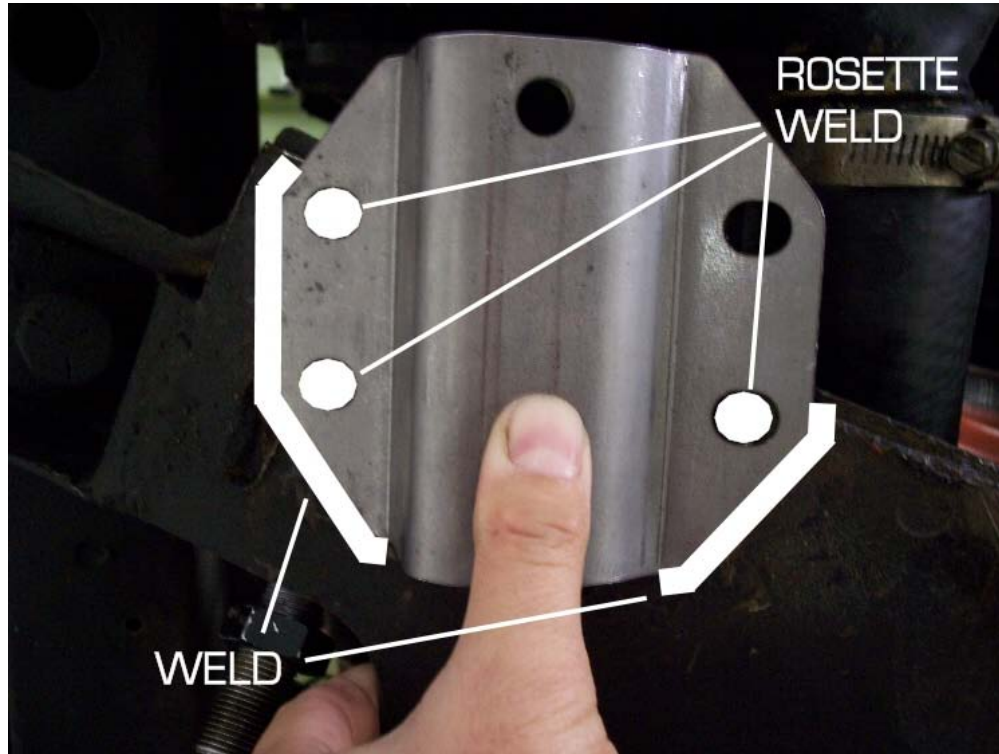

- 5F Grease sway bar bushings with supplied urethane specific grease, re-install sway bar, and end links, and completely tighten all hardware.



## Rear Sway Bar Installation

- 1R First, make sure you do not have a 7-1/4 rear end. The axle tubes will be too small for this kit. The kit will fit all other rear ends with Ø3" axle tubes. Lift the vehicle, and support. Wheels must be at ride height for dog bone frame bracket mock-up. Use of a flat alignment style rack, or drive up ramps preferred.



- 2R Loosely attach sway bar to diff. using the axle u-bolts, axle brackets, and sway bar bushings / brackets.

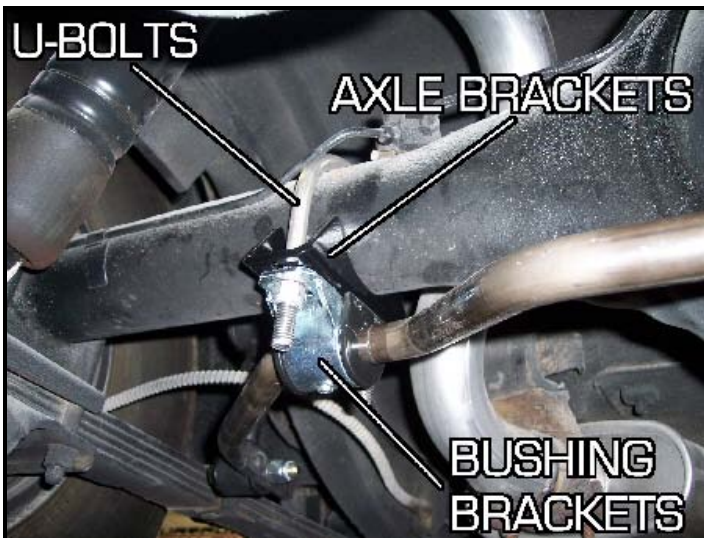



- 3R Loosely attach dog bones to middle hole on sway bar, and to frame brackets. Use hardware kit T1712.

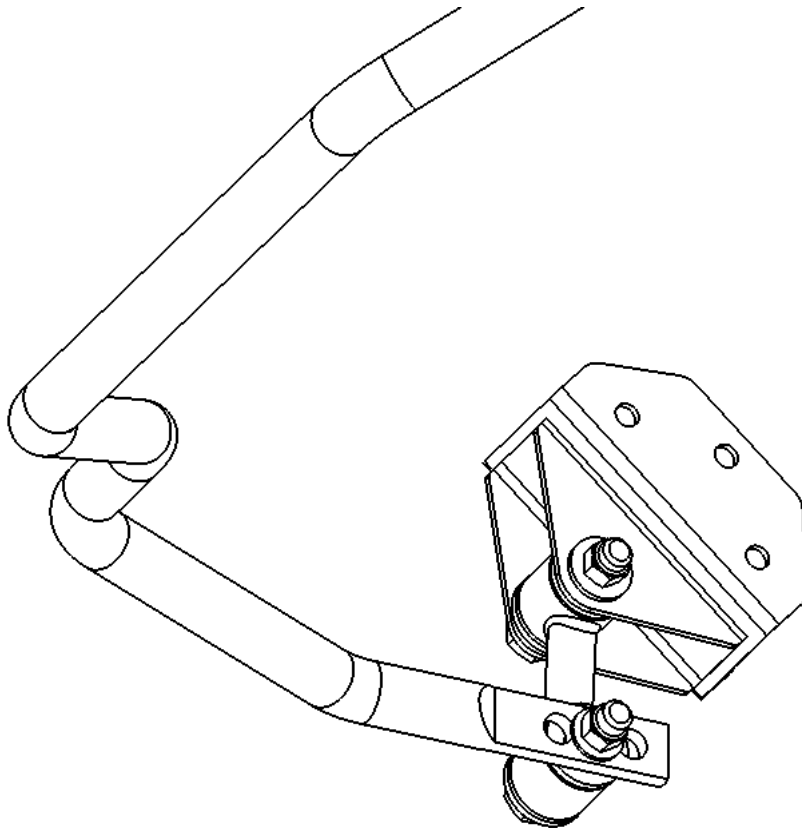

- 4R Rotate sway bar, and frame brackets up until they contact the frame rails. (Fuel lines, and parking brake cables may need to be loosened, and moved for proper placement of frame brackets, and can be re-installed when finished.)

- 5R Shift the bar side to side, and fore & aft in order to evenly align frame brackets, and so that the dog bones are vertical when attached to middle hole in sway bar.

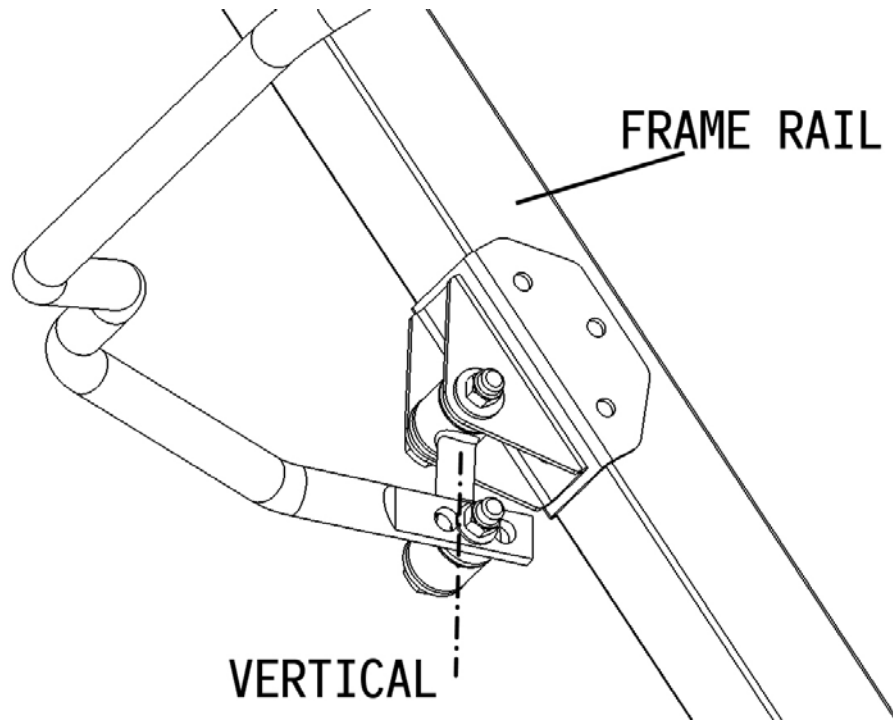

- 6R Clean and prep surface, and tack weld frame brackets to frame rails.
- 7R Verify that brackets are aligned correctly, if not, make necessary adjustments at this time. Remove dog bones from frame brackets, and completely weld in frame brackets. Let cool, and paint surface to prevent rust.

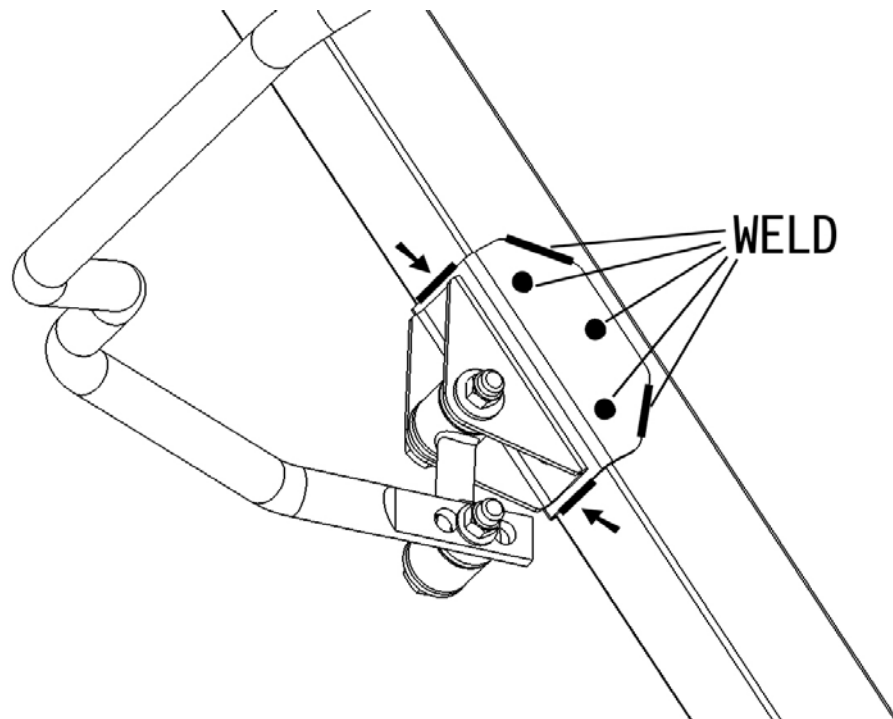

- 8R Grease all bushings with supplied urethane specific grease, re-install sway bar bushings, brackets, and dog bones. Evenly align sway bar so that dog bones are vertical, and completely tighten all hardware.