

14366, 14385 [Adjustable Strut Rods](#)
67-76 Chrysler A-Body 1966-1970
Chrysler B-Body 1970-1974 Chrysler
E-Body



Before You Start:

Please read the entire manual before starting. Most pictures shown are of the passenger side strut rod. Please perform the same procedure for the driver side.

1. Raise Vehicle

Raise the vehicle and put it up on jack stands. You may also use a 2-post or 4-post lift.

2. Disconnect the Front Sway Bar

If your car has a front sway bar, disconnect the front sway bar ends that attach to the lower control arms.

3. Disconnect the Strut Rod From the K-Member

Undo the strut rod nut accessible from the front of the K-member. You may discard this hardware.

4. Disconnect Strut Rod From Lower Control Arm

In order to get the stock strut rod out, you will need to shift the lower control arm toward the rear of the car to gain more room. First undo the nut securing the strut rod to the lower control arm. Retain this nut for reinstallation.

Loosen the torsion bar tensioner bolt located on the bottom of the lower control arm to relieve the load from the torsion bar.

Next, loosen and remove the main nut securing the lower control arm to the k-member.

There is a snap ring at the rear end of the torsion bar that keeps it from moving back. Remove the snap ring and shift the torsion bar 3-4" towards the back.

You should be able to shift the lower control arm slightly towards the back allowing you to pop out the strut rod end out of the lower control arm hole.

The stock strut rod should be free from the vehicle.

5. Install Clevis Assembly onto Strut Rod

Install 2 misalignment spacers onto the heim joint. Insert the ½" bolt, washers and nuts onto the clevis assembly attaching the clevis to the heim joint. Fully tighten the ½" bolt

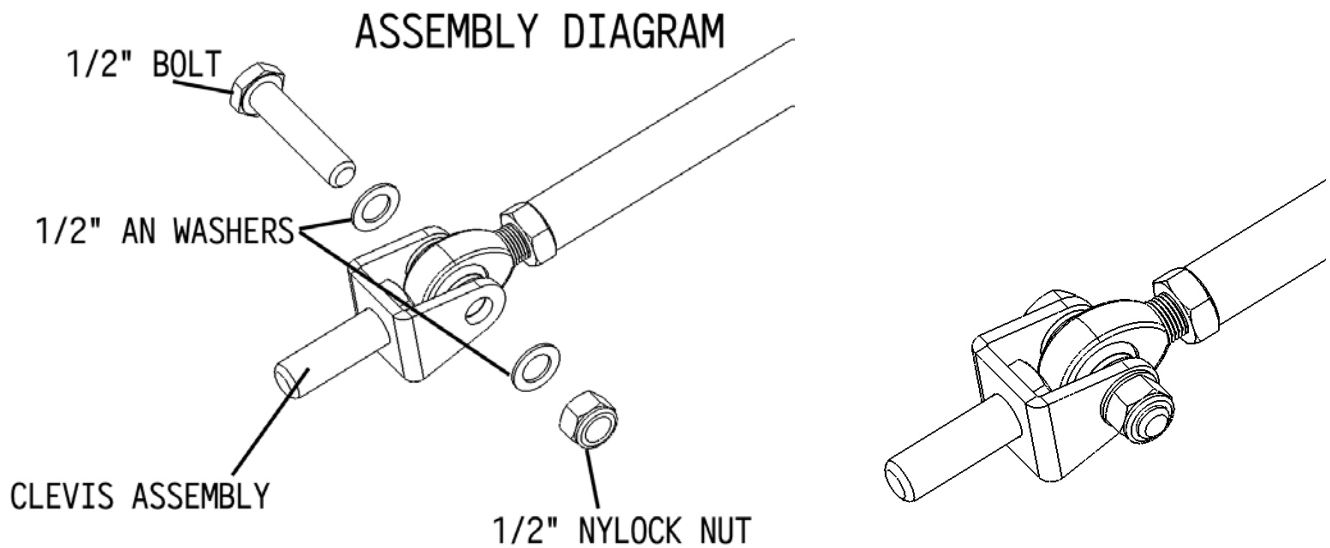
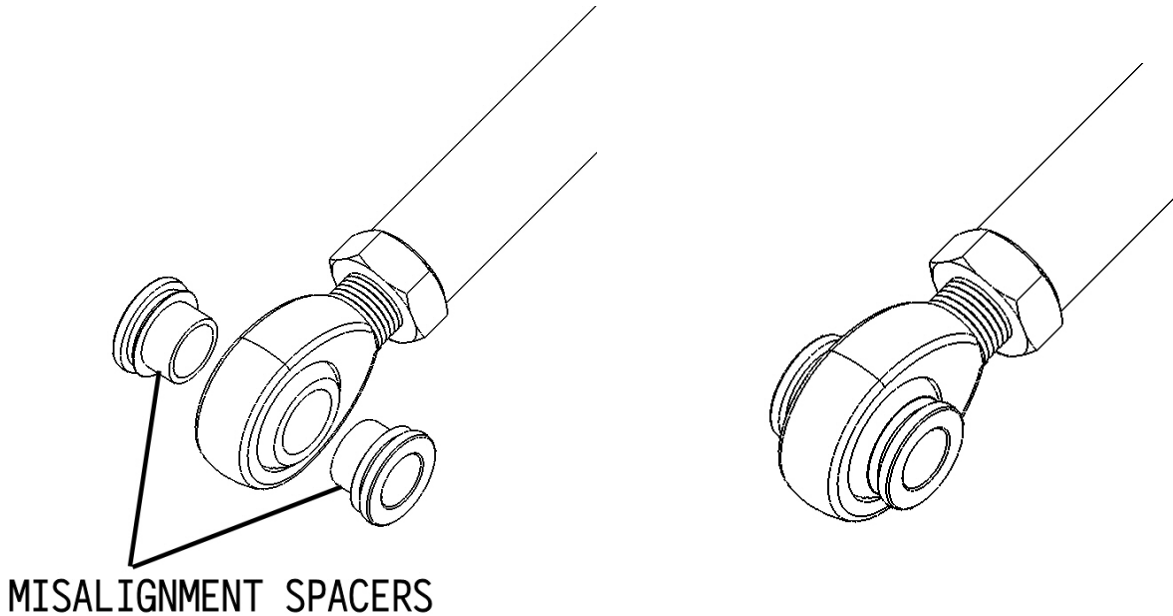

6. Install the Strut Rod

We'll start by bolting in the front end first. Following the diagram below to see the order of parts.

ASSEMBLY DIAGRAM

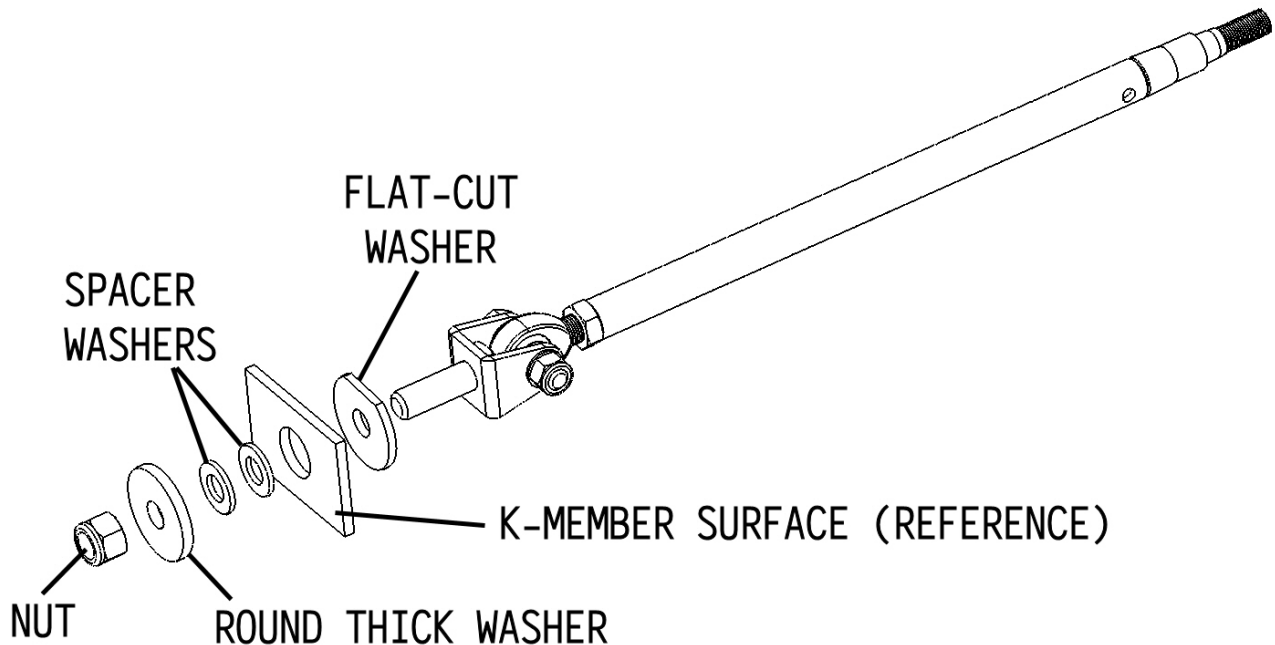

Install the large flat-cut washer onto the clevis stud and insert the front mount into the k-member hole.

If needed, rotate the flat-cut washer to alleviate any clearance issues with the sheet metal.

You will notice that the k-member hole is much larger than the clevis stud. This is ok, since you will be inserting 2 spacer washers from the front side of the k-member to take up the gap. The spacer washers will fit inside the k-member sheet metal.

Once the spacers are in place, install the large round washer and 5/8" nylock nut.

Moving on to the rear mount, insert the rear stud into the lower control arm hole. Do not install the stud nut at this time.

Reinstall the lower control arm back onto the k-member. Push the torsion bar forward and insert it into the lower control arm pin hex.

Next rotate/thread the strut rod body in or out to a desired length. You can dial in more positive caster by shortening the strut rod. Do not over extend the strut rod past the recommended length (see diagram below). Fully tighten the rear strut rod nut.



Center the heim joint so that it is not twisted one way or another. Tighten the heim joint jam nut.

Fully tighten the front strut rod 5/8" nut you installed earlier. To avoid spinning the clevis while tightening, use a pry bar to hold the clevis.

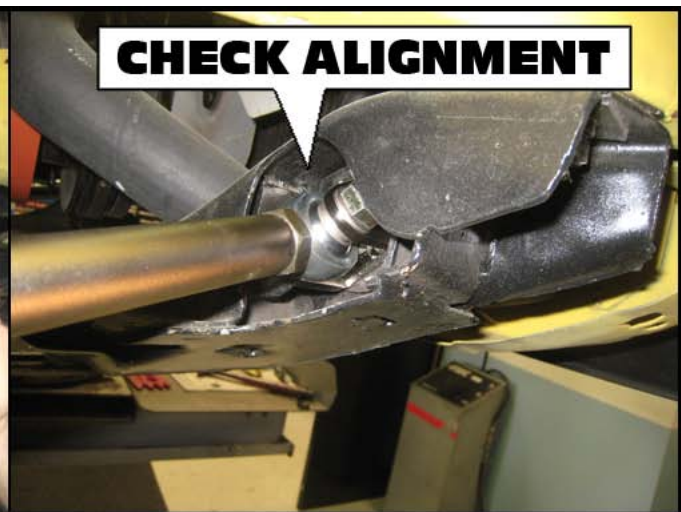

Restore torsion bar snap ring. Adjust the torsion bar tensioner back to where it was for proper pre-load.

7. Repeat on Drivers Side

Repeat the steps on the driver's side and you're done!

