

# **WATKINS MOTORWORKS**

## **SPORT SUSPENSION**

1203AA  
64-67 GM A-BODY  
Double Adjustable  
Trailing Arms

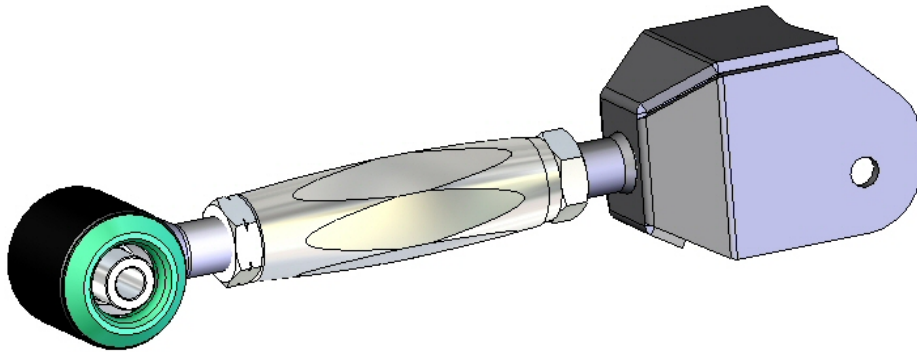

***Warning: This installation should be performed by a trained professional. Note, pictures in this booklet are from a 77-96 GM B Body. Installation for your 64-67 A-Body is very similar.***

Tools Required for this Installation

- 4 post lift or alignment rack preferable
- Air Chisel, Angle Finder (Digital Preferred), Dead blow hammer
- The following sockets or wrenches: 10mm, 13mm, 15mm, 16mm, 18mm, 21mm

### **REMOVAL OF STOCK UPPER TRAILING ARMS**

1. Raise the vehicle to access the rear end section.



2. There are various methods for installing your new upper trailing arms. Preferences in methods are mainly based on the way you remove the old rubber Can Bushings from the differential. Some may find it easier to detach the entire differential (rear end) from the car in order to remove the Can Bushings. This makes it easier to get at the Can bushings for removal and replacement. The only problem with this method is that it requires much more to be disconnected e.g. brake lines, parking brake, axle u-joint, and lower trailing arms. However, it is possible to remove the Can Bushings without taking the rear end off the car, but it's tricky.

In this manual, we will describe how to replace the Can Bushings without removing the rear end from the car.

3. First, raise the rear of the vehicle so that the rear wheels are off the ground. If you are using a 2-post lift, support the differential with a hydraulic tranny jack.
4. Remove the rear shocks.



5. Remove the rear sway bar from the lower trailing arms.



6. Allow the differential to droop as far down as possible.

7. Remove the stock upper trailing arms.





8. Now here comes the difficult part; removing the stock Can Bushings. These are the bushings that connect the aft end of the upper trailing arms to the differential. You may luck out and be able to hammer them out with a dead blow hammer, but if you are not able to use this method please do the following.
- First step is to drill out the rubber bushing. Drill a sequence of holes in a circular pattern in the rubber.

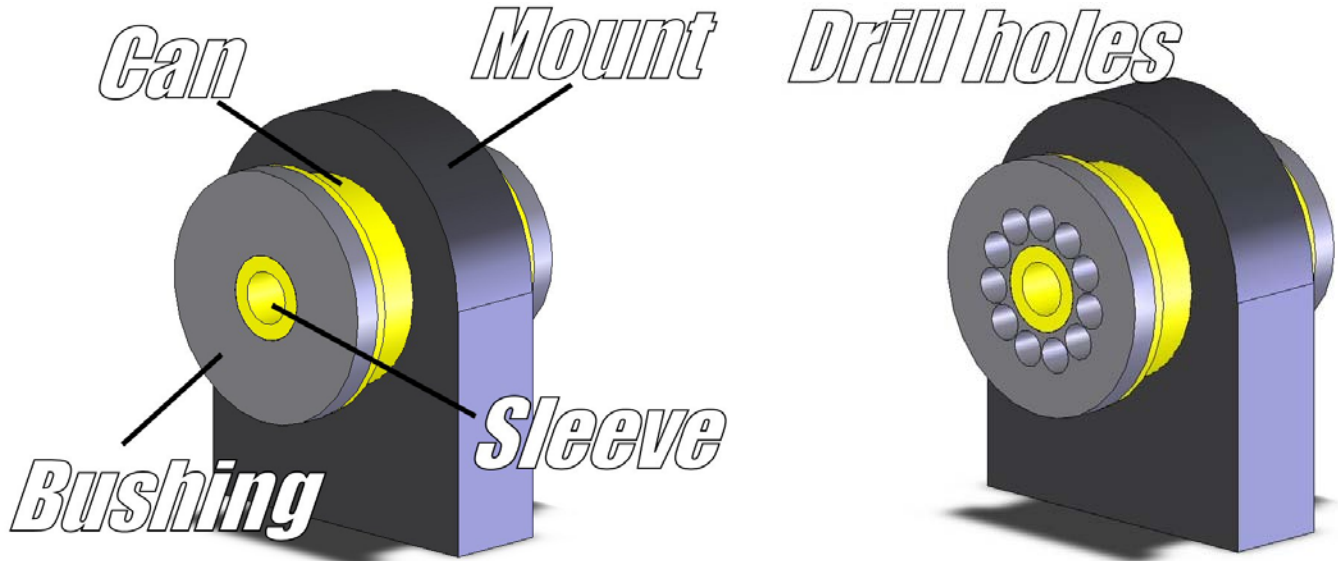

- Once the rubber surrounding the inner metal sleeve is pretty much drilled out, you should be able to punch out the metal sleeve.

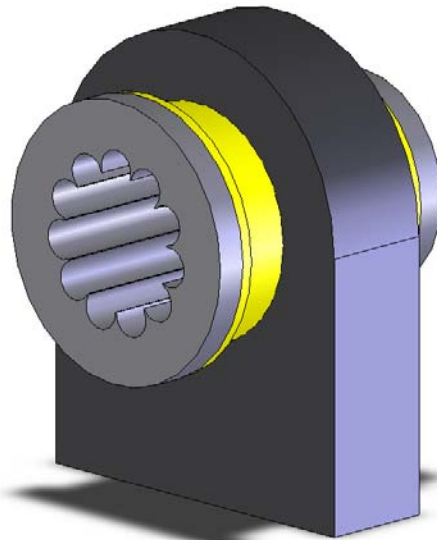

- Scrape or pull out the remaining rubber in the bushing can. All that should be left is the metal can

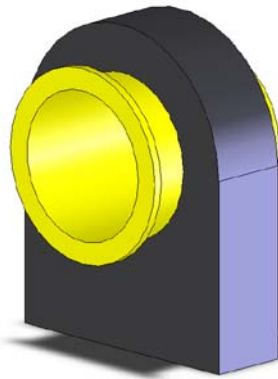

- Soak the entire can with some good penetrating oil. Let it sit for about 20-30 minutes.
- Grab your trusty air chisel and hammer away at the flange in the direction of extraction.

## *Air Chisel*

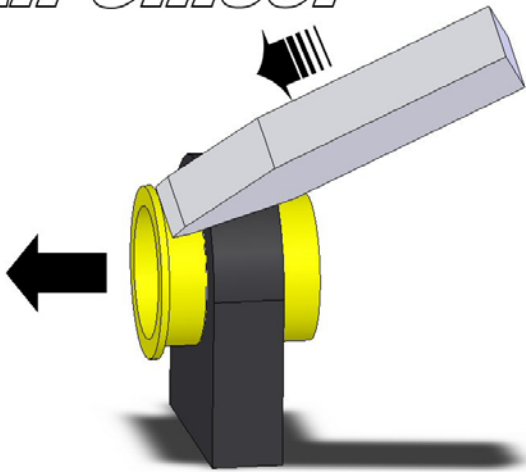

- If the flange begins to tear or bend then it may necessary to chisel the other end of the can to fold the edge over. This way you have something to chisel onto in the direction of extraction.

## 9. *Fold*

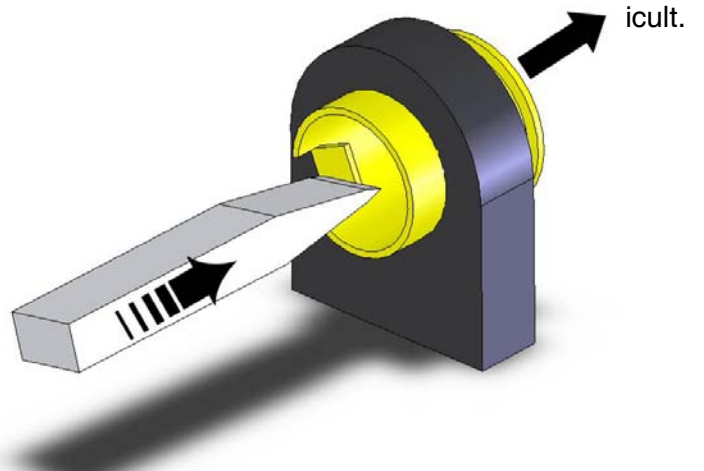
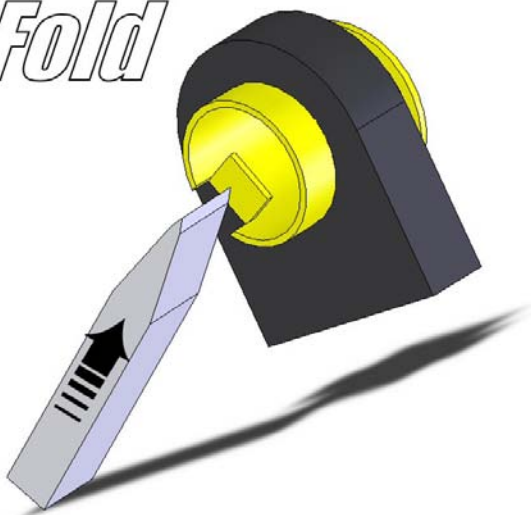

*Clean*

*&*

*oil*

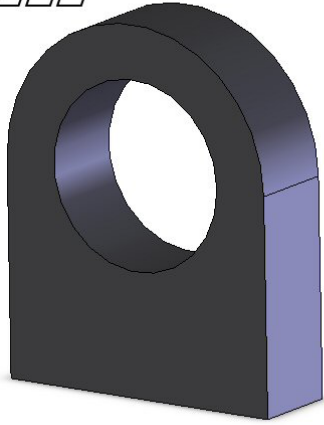

### ***INSTALLING NEW UPPER TRAILING ARMS***

10. The new polyurethane can bushings come pre-assembled, but it is easier to install the new can bushing with the polyurethane bushing out of the metal can. So, the bushing will have to be pressed out.

- First, set the bushing (flange down) in a vise. See picture. Notice the flange sits on top of the vise. It is not compressed in the vise.



- Using a dead blow hammer, smack the bushing downward until the bushing is level with the metal edge.





11. Normally with enough room, you can place the bushing can in the differential mount and hammer it in with a flat piece of wood. But, if there isn't enough room, then you will have to fabricate your own press tool. This is not as hard as it sounds.

Home made press materials:

- (2) steel plates (2 ½" x 2 ½" x ¼" thick)
- (2) 2" ID metal pipe (≈1" long "short", ≈ 2" long "deep")  
Note: these lengths may vary based on your bolt thread length
- (1) ½" Bolt 5" long Grade 8
- (1) ½" Nut Grade 8
- (2) ½" Washers Grade 8

You should be able to find these supplies at your local hardware store.

Assemble the materials as shown in the diagram.

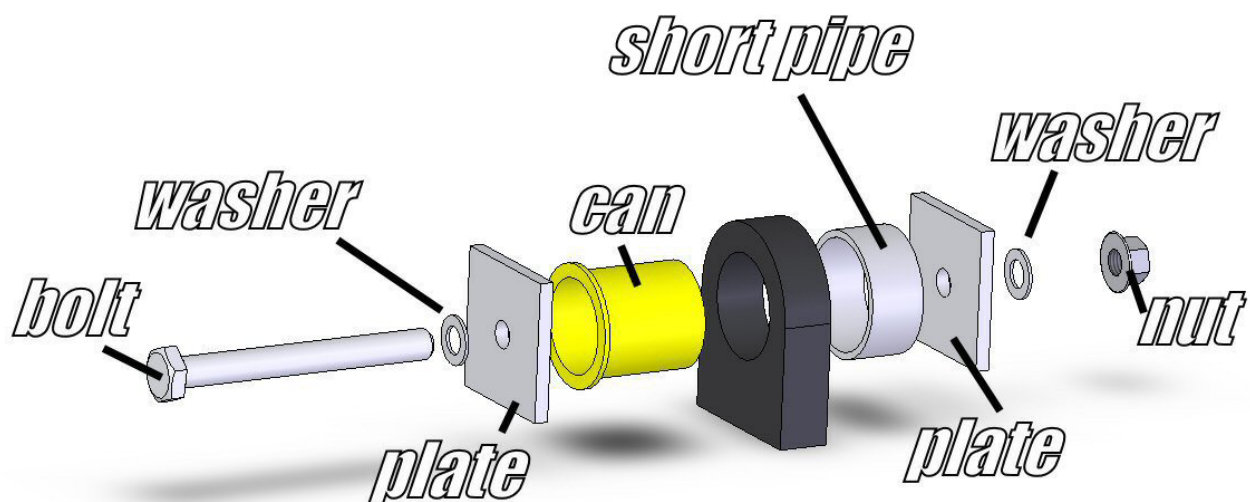

Use a ¾" wrench to hold the nut and a ¾" socket to tighten the bolt. The bolt may eventually run out of thread. When this occurs, you can replace the short pipe with the deep pipe.



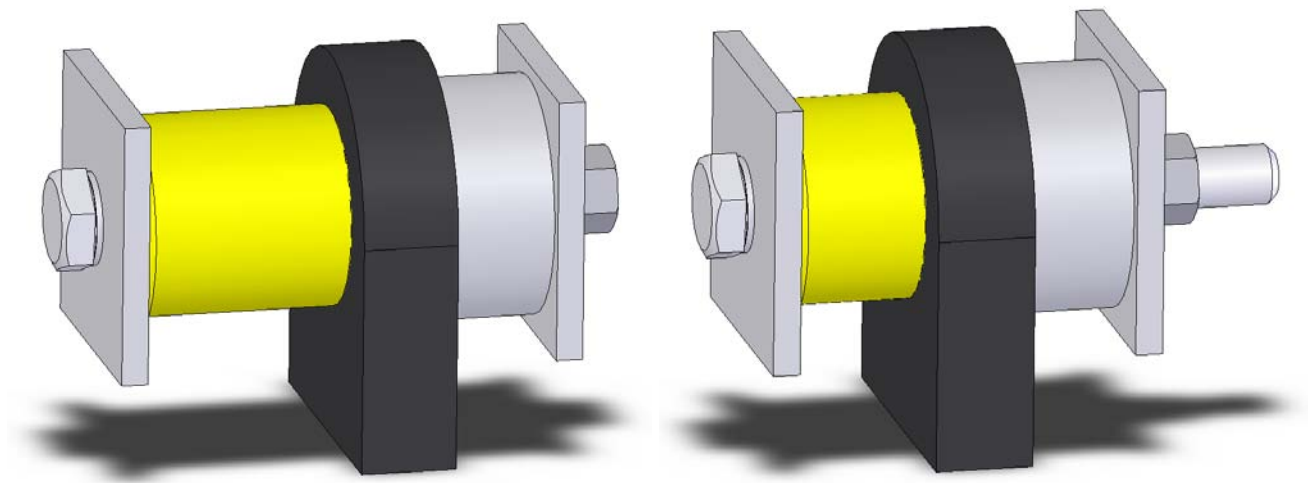

*Stop at Crease*

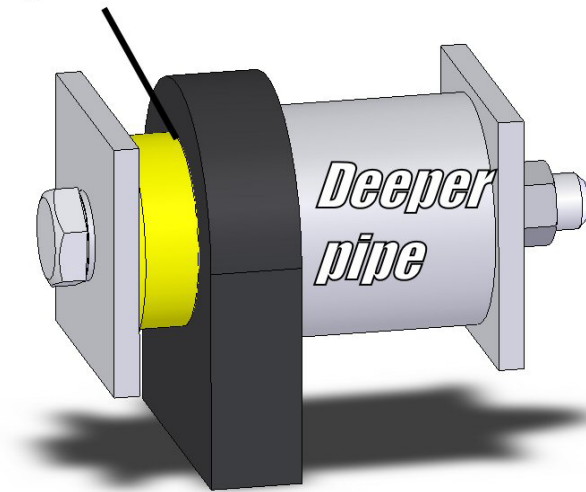

Press the metal can in until it reaches the crease.



Important Note: On 12-bolt differentials, you cannot use the homemade press method. This is because the thrust bushing (see step 13) needs to be installed onto the can just before the can is fully pressed in. The thrust washer also needs to be shaved down in order to clear the differential housing. In this instance, use a dead blow hammer to smack the can into the mount hole.





12. Once both cans are pressed in, lube the polyurethane bushings and push them into the can in the same manner. You may need to use a dead blow hammer or large channel locks to get the bushing in all the way.

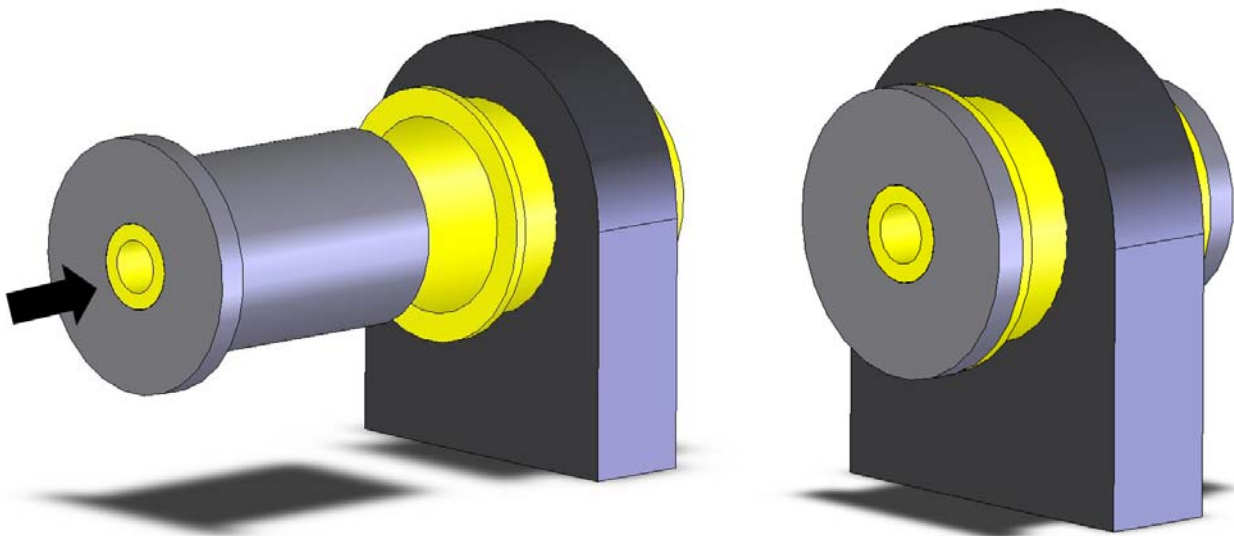

13. Install the thrust washer onto the unflanged side of the can.

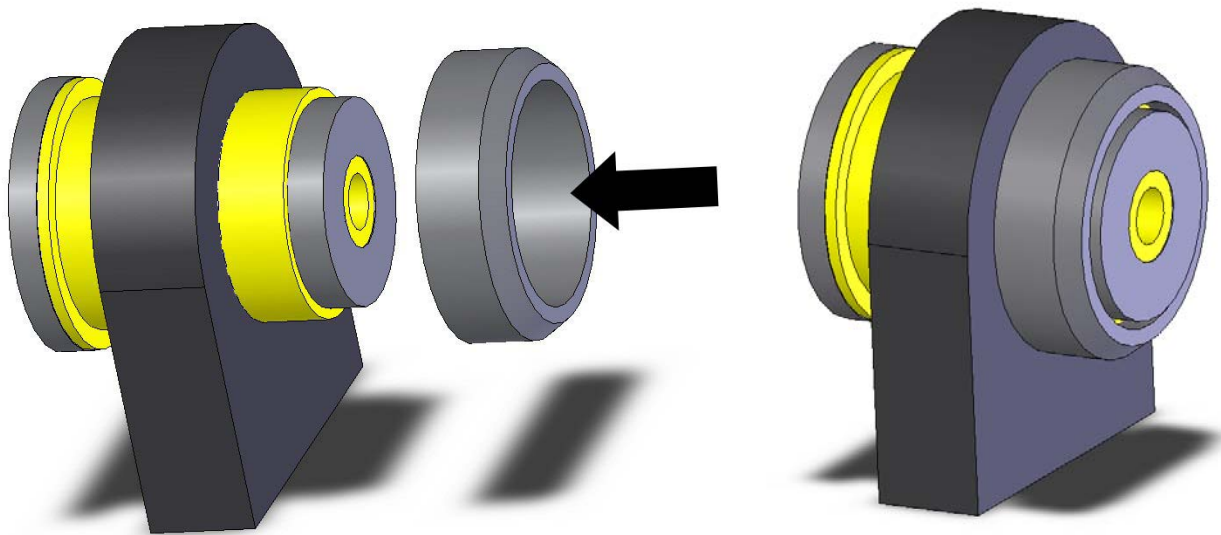

12. Install your new Hotchkis adjustable upper trailing arms in the same manner as the stock removal. Make sure the grease fittings on the front end are facing downward. Use all new hardware provided in your kit.



14. Reinstall the rear shocks and sway bar.

15. Make sure all hardware is fully tightened.

## SETTING PINION ANGLE

It may be necessary to set pinion angle after installation of your new Hotchkis upper trailing arms.

First of all, what is pinion angle? Pinion angle is basically the angle between the centerline of the differential pinion and the drive shaft centerline. This angle changes during acceleration and braking. If the pinion angle is excessive, then vibration and increased U-joint wear will occur.

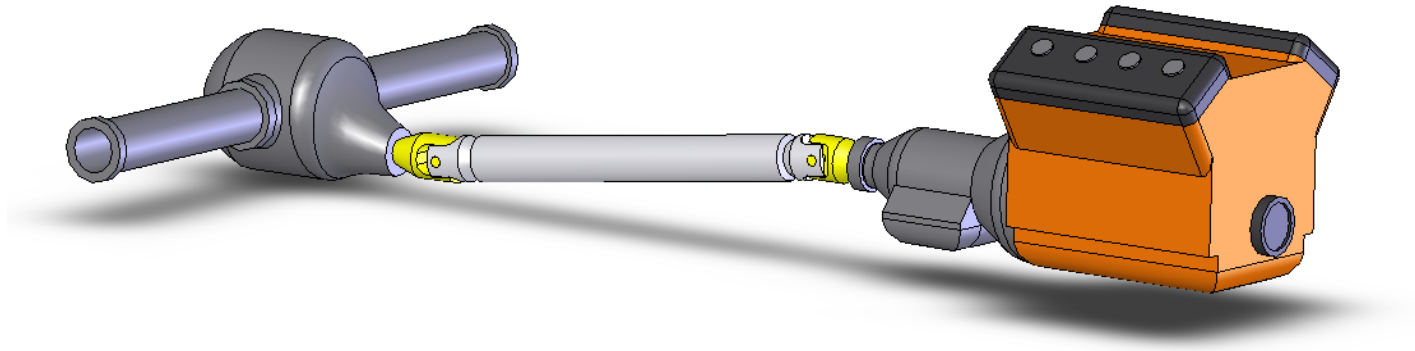

The Hotchkis double adjustable trailing arms allow you to adjust the pinion angle with ease. Simply loosen the two jam nuts and rotate the aluminum turnbuckle to lengthen or shorten the arm. So, how does one set the pinion angle?

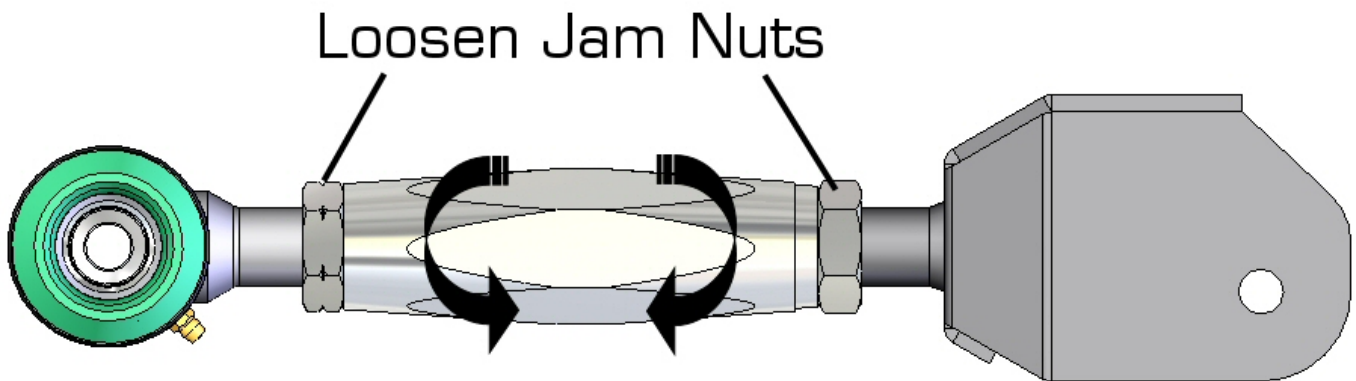

The simplest rule of thumb is:

The centerline of the differential pinion should be parallel to the centerline of the engine's crankshaft without being the same line.

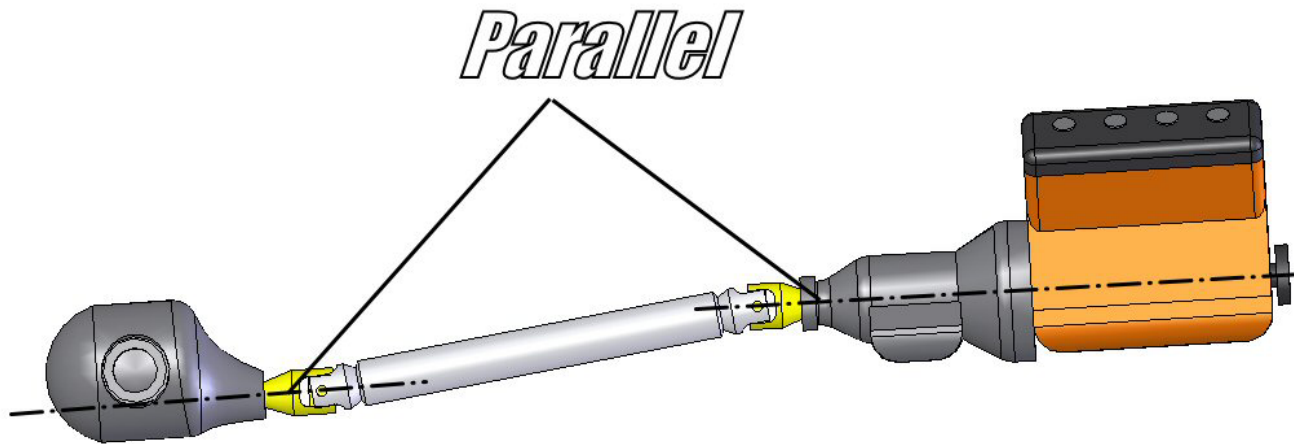

FYI... The centerlines should not be the same line because the U-joints would wear in the same areas all the time. Having an angle at the joint itself allows the joint to articulate and wear evenly along the entire bearing race.

So, the first thing to do is to find out the angle the engine's crankshaft is sitting at. One way to do this is to set a digital angle finder on the front crank pulley or harmonic balancer. Record this angle. Next, set the digital angle finder on the front flat face of the differential yoke. This angle needs to be the same as the recorded crank angle. Adjust your Hotchkis trailing arms to obtain the angle needed.

Tighten all hardware and drive the car. Test for driveline vibration by accelerating.

**If there is vibration during acceleration, then the pinion angle is set too high!**

*During Acceleration*

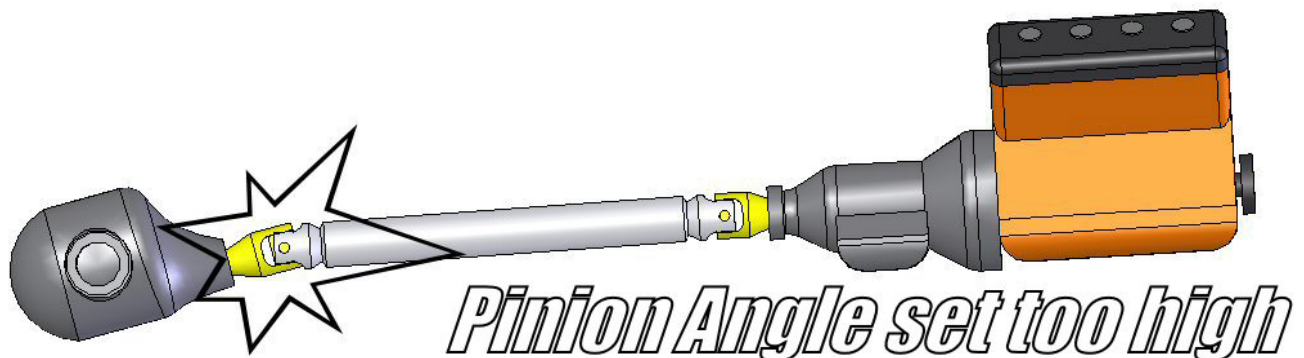

**If there is vibration during braking, then the pinion angle is set too low!**



*During Braking*

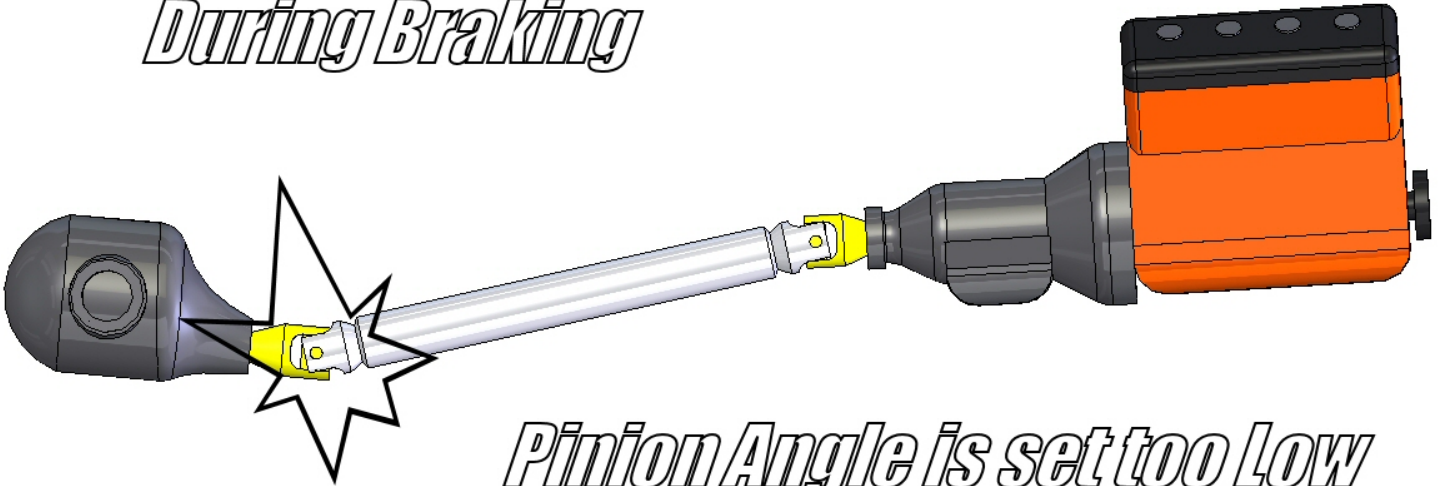

*Pinion Angle is set too Low*

Fine tune your Hotchkis trailing arms to achieve the perfect setting for your driving style and horsepower.

*During Acceleration*

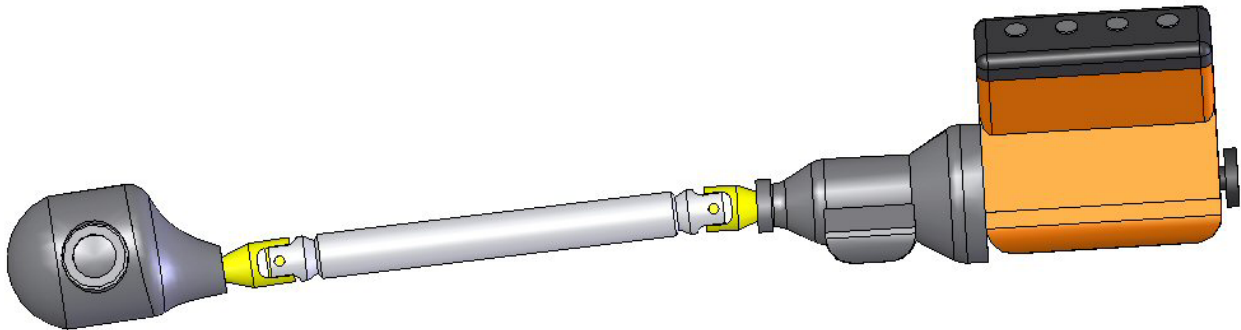

*Adjusted Pinion Angle*



## INSTALLATION INSTRUCTIONS

**1301 / 1302 / 1305 / 1306**

THANK YOU FOR CHOOSING HOTCHKIS PERFORMANCE PRODUCTS

### **Removal of Stock Lower Trailing Arms**

- 1) Place car on level surface.
- 2) Support rear of the car on jack stands and remove the rear wheels.
- 3) Remove the rear sway bar. (if car is equipped-not required on Camaro/Firebird)
- 4) Place a floor jack under the differential and lift up slightly to remove tension from the trailing arm bolts-make sure not to lift the car off the jack stands.

**KEEP THE FLOOR JACK UNDER THE CAR DURING THE COMPLETE REMOVAL AND INSTALLATION PROCEDURE.**

**CAUTION- DO NOT REMOVE BOTH TRAILING ARMS AT THE SAME TIME OR THE AXLE WILL ROTATE AND THE TRAILING ARM INSTALLATION WILL BECOME MUCH MORE DIFFICULT.**

- 5) Start with either lower trailing arm and remove the rear bolt.
- 6) Then remove the front trailing arm bolt using a socket with an extension-place the socket through the outer hole in the frame to loosen the nut ( Does not apply to F body). **Caution** – be careful not to drop the bolt into the frame – if you do then remove the bolt through the large hole on the underside of the frame.
- 7) Remove the unbolted trailing arm.
- 8) Clean the frame at the trailing arm pivot area with a wire brush.

### **Installation of HP Lower Trailing Arms**

Hotchkis performance trailing arms are fully assembled, greased and ready to install.

- 1) Apply a thin layer of chassis grease to faces of bushings before installation.
- 2) Install HP trailing arms with the grease fittings facing down and the sway bar mounting holes toward the **rear** of the car.
- 3) Install the new trailing arm by locating the front bolt first.
- 4) Place one drop of blue **Loctite** on clean threads and torque the nut to 70 ft./lbs.
- 5) The trailing arm should then pivot smoothly on the chassis.
- 6) Install the rear bolt.
- 7) Place one drop of blue **Loctite** on clean threads and torque nut to 70 ft./lbs.
- 8) Install the rear sway bar using the stock or supplied bolts. ( 7/16" on early models-10mm late models 78 on) (1305 trailing arms have supplied hardware) **Does not apply to F body.**

- 9) Place one drop of blue **Loctite** on clean threads and torque sway bar nuts to 35 ft./lbs.  
**Note:** **Loctite** not needed if using new Hotchkis Performance hardware.
- 10) The holes located on the Hotchkis Performance lower control arms are for the mounting of our sway bar.

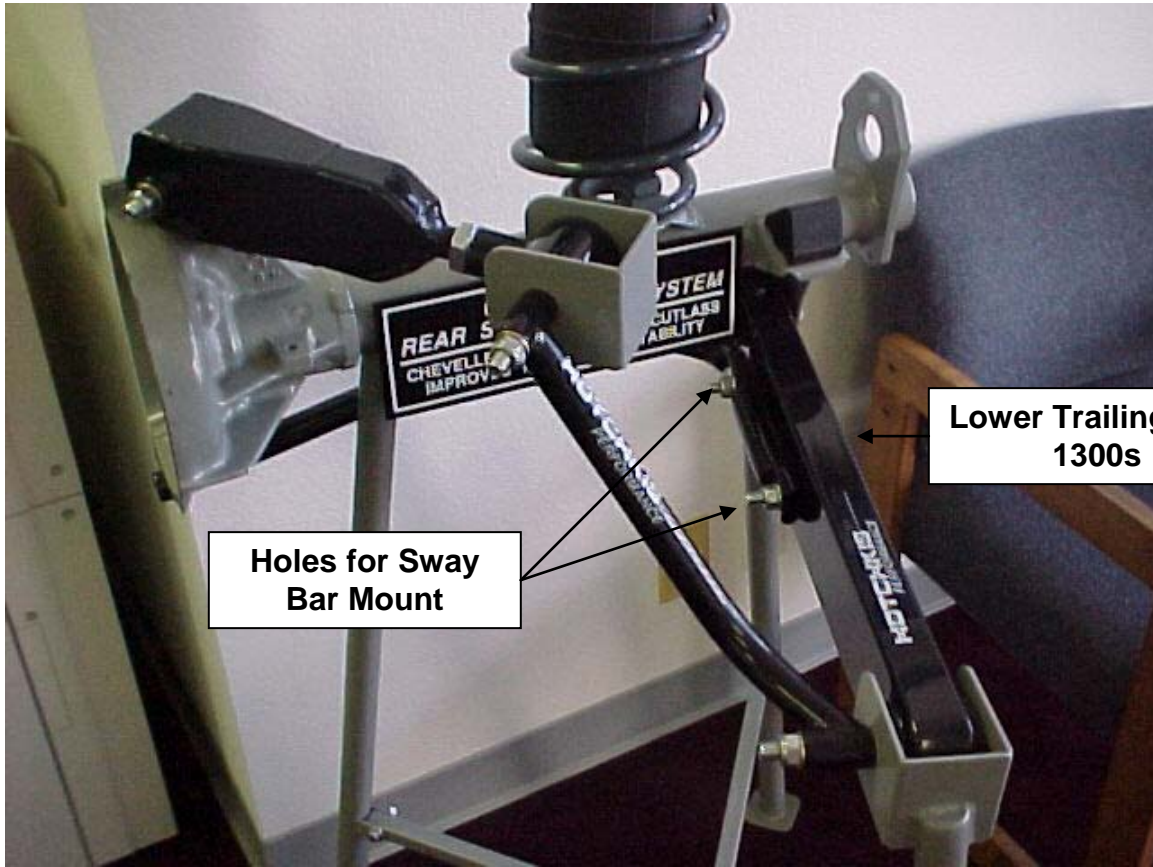

# <sup>+</sup> HOTCHKIS SPORT SUSPENSION

## 1401 / 1402 / 1403 ADJUSTABLE TRAILING ARM MOUNT BRACES

1401 – 78-88 GM A/G-BODY / 1402 – 68-72 GM A-BODY / 1403 – 64-67 GM A-BODY

### INSTALLATION OF HOTCHKIS PERFORMANCE ADJUSTABLE TRAILING ARM MOUNT BRACES

**ALWAYS USE CAUTION! - AND MAKE SURE THE CAR IS SECURE ON JACK STANDS.**

- 1) Place the vehicle on a level surface. Block the front tires.
- 2) Use a jack to lift the rear of the car until the suspension is at full droop and the tires are no longer contacting the ground. Support the rear of car on jack stands.
- 3) Place the jack under the differential. This will be used later to lower or raise the axle for ease of installation.
- 4) Use a ratchet or wrench to remove rear shock absorbers at the lower mounts. This should free up the springs to be removed.





- 5) Using the jack placed under the differential, raise the rear suspension to its approximate ride height. The braces are generally easier to install with the rear axle at its normal ride height position to the frame.

**NOTE:** Be careful not to unload the weight of car off the jack stands.

To keep the axle from rotating, **install one brace at a time.** **Do not** have trailing arm bolts removed from opposite sides at the same time.

- 6) Remove one front upper trailing arm bolt and replace with supplied longer bolt and washer. Push bolt through trailing arm until about 1/2" of thread is showing. A short amount of thread makes it easier to slide the brace onto the bolt.

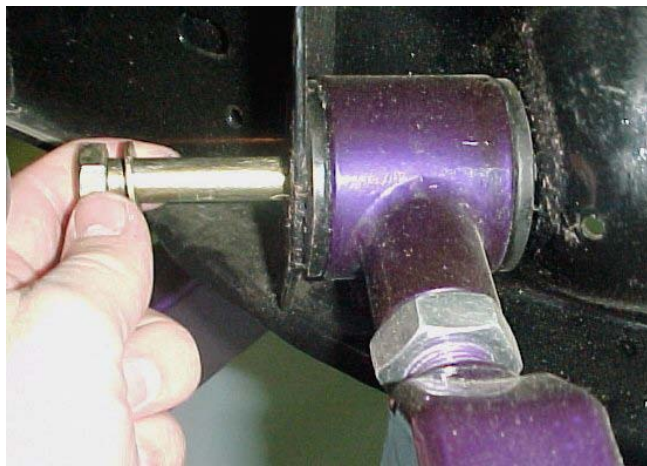

**NOTE:** If the emergency brake cable covers the upper trailing arm bolt, then this cable will have to be moved slightly. Do this by removing the cable bracket bolt just above the pinion. Push the cable aside for the brace clearance.

- 7) Repeat step 6 for the front bolt of the lower trailing arm. Access to this bolt should be through a hole in the outside of the frame that can be reached with a socket and ratchet extension.

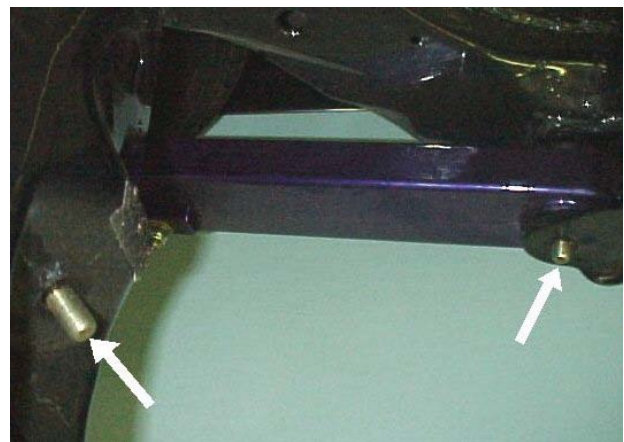

*These pictures were taken on a bare frame for reference.*

- 8) The brace can now be installed by sliding it over the bolts. The braces connect the upper and lower trailing arm frame mounts as indicated by the arrows in the photo from step 7. The longer section of the brace fits next to the lower trailing arm.



**NOTE:** For 78-88 models (part #1401) the curved section fits next to the lower trailing arm between the rear seat pan and the frame cross-member as shown in the photos below.





- 9) Adjust the length of the brace as necessary. Loosen the jamb nut on the brace with 15/16” wrench to allow the head to move. Rotate the head **clockwise to shorten** the brace or **counter-clockwise to lengthen** the brace until it fits over the ends of the bolts. The brace ends should fit almost flush to the frame with the bolts fully extended through the ends.



**YOU WILL NOT,** be able to determine if you have the right brace length until you have fully extended the bolts and the brace fits without causing the hardware to bind.

Hand-tighten the jamb nut on the brace. Place the washers included over the bolt ends and start the nylock nuts on the bolt ends to make sure the bolts don't pull out, and move on to the next step.

**Special Note (68-72 Models):** Due to tolerances in these models it may be necessary to clearance the floor pan to fit these braces. Use a body hammer to clearance the floor pan from the braces.

- 10) Repeat the installation & adjustment procedures for the opposite side.

- 11) Once the braces are installed, place one drop of ***Loctite*** on the trailing arm bolt threads. Tighten the washers and nuts. Torque the nuts to 60 ft./lbs. You may have to use a wrench and socket together to keep the hardware from spinning.

**NOTE:** If using rubber trailing arm bushings, then raise the differential to approximate ride height and tighten the trailing arm bolts. Polyurethane equipped trailing arms can be tightened at full suspension droop.

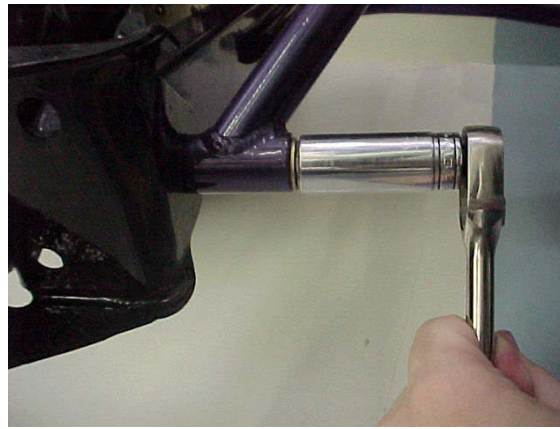

- 12) Use the 15/16" wrench from before to tighten the jamb nut on the brace.
- 13) Replace the brake cable if it was moved earlier.
- 14) Re-install the springs and bolt the shocks back into place. **CHECK THAT ALL HARDWARE IS TIGHT!** Lower the jack from the differential and remove the jack. Use the jack to remove the jack stands supporting the rear of the vehicle. Remove the blocks from the front wheels and you're done with the installation!

**CHECK ALL NUT AND BOLT TIGHTNESS AFTER FIRST 10 MILES**





## 1916F 1964-1972 GM A-Body Big Block Front Coils Special Note

***Please read the following special note regarding your new Hotchkis Coil Springs before attempting this install.***

Although our coils were designed to drop a typical stock GM A-Body by 1", we have observed that this ride height drop is not 100% consistent due to variations of engine modification (e.g. Aluminum heads) and other different components that affect the vehicles weight.

Our coils generally sit either perfect or higher than desired. So, our springs will never be too low straight from the box. This will leave room for the installer to play with the ride height by cutting the bottom end of the spring if the ride height is too high for your application. **We recommend that you do not exceed cutting more than 1 full coil off.** Reducing the amounting of coils will slightly increase the spring rate, but the spring will perform just the same. You do not have to worry about weakening or over-stressing the spring after cutting.

### **Notes for Cutting the Spring:**

- First check to see if the coil spring drops your car at a desired ride height straight from the box. If so, you do not have to cut them.
- Measure the fender to ground distance and estimate how much more you would like to drop it.
- Once the coil is removed, measure the free length of the coil before you cut anything.
- Do Not cut more than 1 full coil.
- The spring/A-arm motion ratio is approximately 2:1, so for every 1 inch of Free-Length you cut off the spring the car will lower 2". This is only an approximation. We suggest you cut the spring conservatively. So for example, if you want to lower the car more by 1", you may want to cut the spring's Free-Length by 3/8" or 7/16". If you need to cut more, than cut more. What you don't want to do is cut too much and have the car sit too low. Please see the picture on the next page for descriptions on what end to cut and what we specify as the Free-Length of the spring. Warning: Springs can not be returned once they are cut, so please take your time and cut in small increments.
- You will have to re-install the spring each time to verify the new ride height.
- Make sure when installing the springs that the top of the coil is seated properly and the lower end is indexed in the lower control arm bucket. Failure to do so may result in inaccurate ride heights and will appear to be too high.
- Always use safety glasses to protect your eyes when cutting the coils.
- This is a trial and error procedure, so please be patient.
- Do not damage any other coils during cutting.

- Please see the following page for more detail.



- Warranty may be void if any problems arise due to installation error.

# **HOTCHKIS**

---

# **HOTCHKIS**

## **SPORT SUSPENSION**

2282

*1964-1972 GM A Body*  
*Extreme Sway Bar Kit*

**Before You Start:**

Please read this entire instruction manual before starting. Being prepared with the right tools and procedures will aid in the ease of this installation.

This sway bar kit requires Hotchkis Trailing Arms (p/n 1302) to be installed beforehand. You will not be able to install this kit using stock trailing arms due to end link interference.

## Front Bar Installation

1. Look carefully at the current installation.
2. This installation can be performed without removing the front wheels . Always use proper safety devices such as jack stands or lift jacks to properly support the vehicle.
3. Loosen front bushing retaining bolts, leave a few threads engaged to support the bar.
4. Remove the factory end link from the car.
5. Support or hold the center of bar and carefully remove front bushing bolts.
6. Remove factory bar from vehicle, taking note of the placement of the swaybar bushings.

- Using the included white silicone grease, grease the inside of the urethane 1 7/16" in sway bar bushings. (The silicone grease can be cleaned up with WD40.)



- Install the urethane bushings on the bar. Make sure you position the bushing so when the bar is installed in the vehicle, the split will face the front of the car.
- Place the bushing's bracket over top the bushing.



- Install the new swaybar into the car using the included Cap Screws on the new brackets. This step will take some manipulating, as the original car was designed for a very small sway bar. You will need a 1/4" or a 6mm Allen Driver Socket for this. Our swaybar set is a much larger diameter than stock bar, and our Heavy Duty sway bar bushings and brackets are larger as well. You might find it easier to slightly squeeze the brackets together in a vice to allow you to better align the bracket holes with the original factory holes. Using a ratchet or air impact, install the screws with a washer under each head. This does work very well, you just need to use some torque to install these bolts. Have patience with this step.



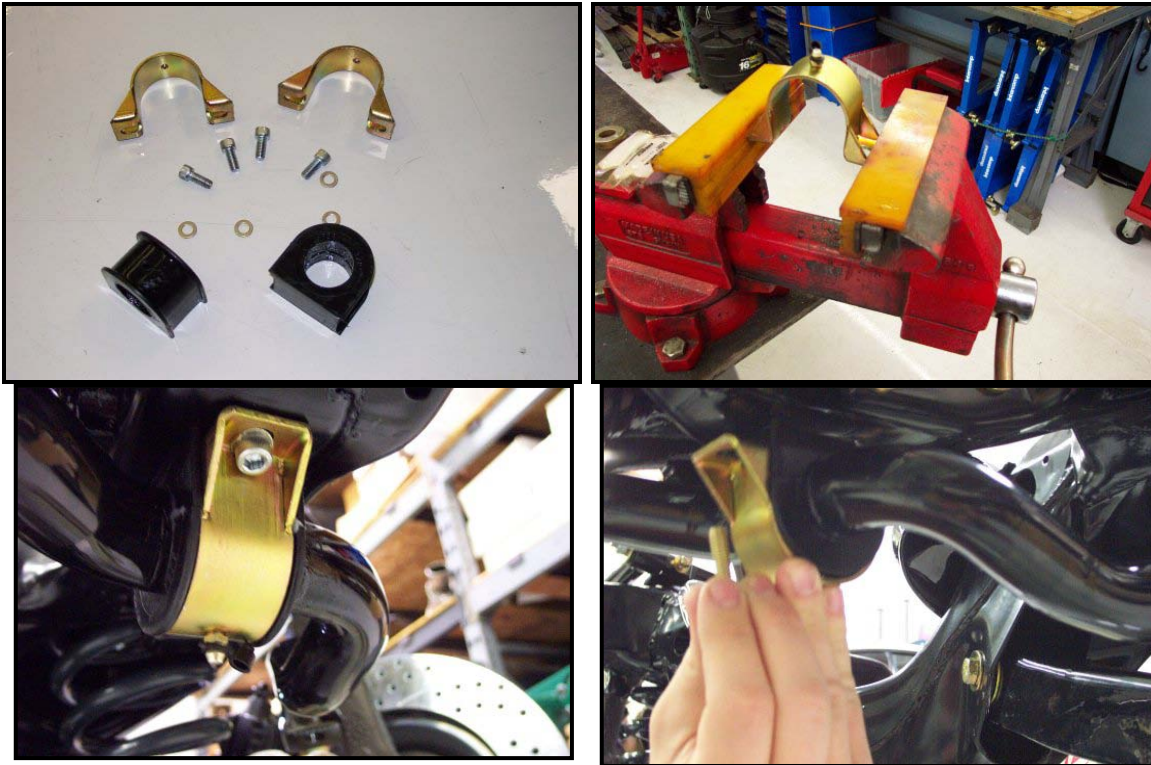

11. Install the new A-Arm endlinks using a ratchet and wrench.
12. Tighten end link nut to the point where the end link bushing's diameter is just larger than it's support washer.



## Rear Bar Installation

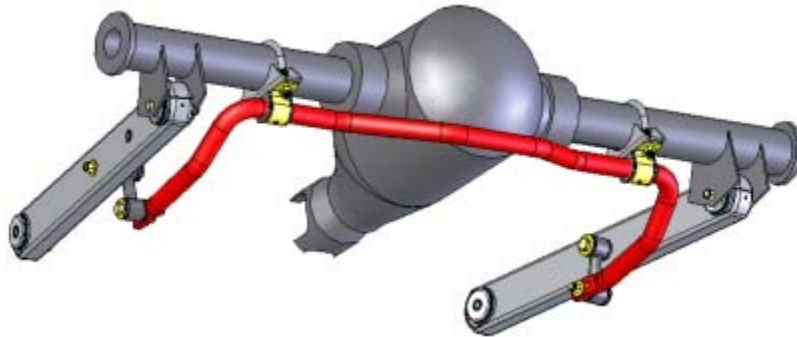

### **Before You Start:**

This sway bar kit requires Hotchkis Trailing Arms (p/n 1302) to be installed beforehand. You will not be able to install this kit using stock trailing arms due to end link interference.

### **1. Raise Rear of the Vehicle**

To properly install the rear sway bar you must have the rear suspension at ride height. Please use a 4-post lift or alignment rack to raise the vehicle. If these are not available, you may use floor ramps to gain access to the underside of the vehicle. Floor ramps can be found at most local auto parts stores.

### **2. Install Hotchkis End Links**

Lube the polyurethane bushing surface on both dogbone end links. Look at your dogbone and notice that the bushing sleeves on each end have different inner diameters. The trailing arm bolt will use the small sleeve and the sway bar bolt will use the large hole. Use the 7/16" x 4" bolt to attach the end link to the trailing arm. The bolt should be pointing inboard. Use the 7/16" SAE washer (small) on the bolt head side and the 7/16" USS washer (larger) on the nut side. Do not fully tighten at this time.



### 3. Attach Sway Bar to the End Links

Orient the sway bar so that the Hotchkis sticker is right side up. At this time you can choose the stiffness setting by using the hole at the end for a softer setting or the 2<sup>nd</sup> hole from the end for a harder setting. Use the 1/2" x 3" bolt to attach the sway bar to the end link. The bolt should be pointing inboard. Use the 1/2" SAE washer (small) on the bolt head side and the 1/2" USS washer (larger) on the nut side. Do not fully tighten at this time.



### 4. Install Axle Brackets

First step is to install the provided stainless steel U-bolts. Each U-bolt will install a little inboard of the spring mount. You will have to unclip the brake line from the axle tab and carefully pull the brake line away from the axle tube to give enough clearance for the U-bolts.





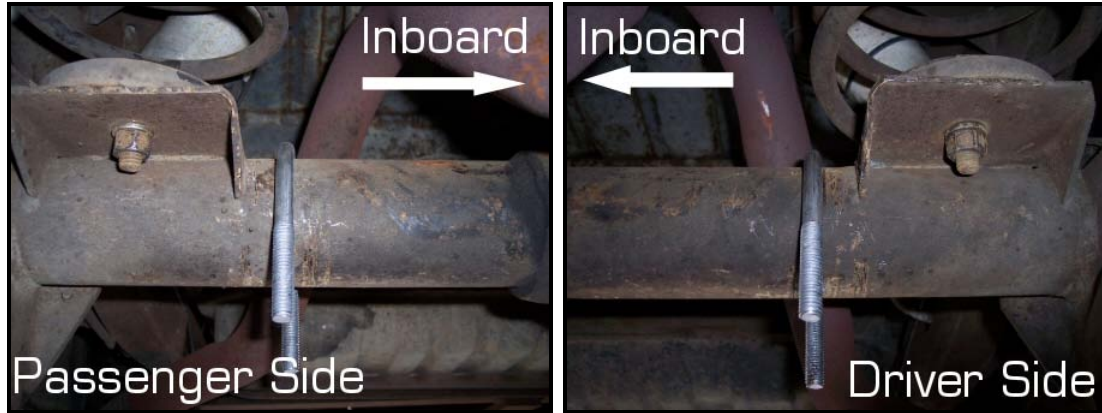

Next, apply the provided lube on the inside surface of the polyurethane bushings. Pop the bushings onto the sway bar. Slide the bushing brackets onto the bushings.

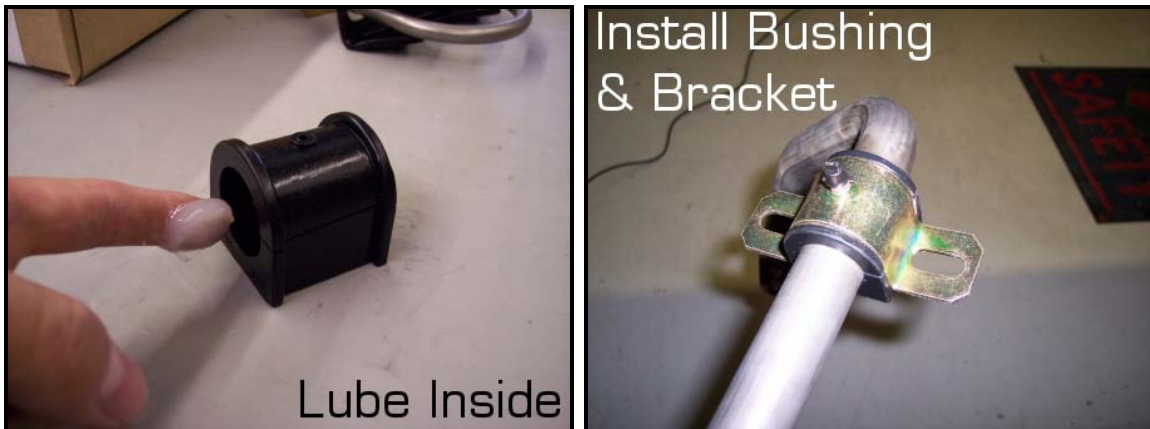

Apply a small amount of anti-seize to the threads of the U-bolts. Next position the axle bracket up against the axle tube. Raise the sway bar up to meet the axle bracket and allow the U-bolts to poke through the bushing bracket. Fasten the assembly together with the provided nut and washer. Do not fully tighten.





### 5. Position the Sway Bar

Since all of the hardware is still semi-loose, we can position the sway bar so that the end links are perpendicular to the trailing arm. Once the bar is positioned, fully tighten the axle bracket U-bolts. Then fully tighten the rest of the hardware. You are finished with this installation.

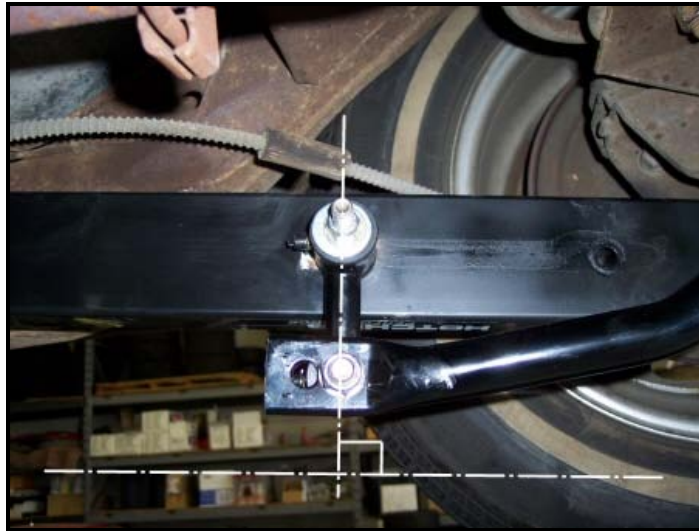

### 6. Optional Reinforcement

If the vehicle is going to be drag racing or road racing, it is recommended that you weld the axle brackets to the axle tubes. Sand off the paint on the mating edge of the axle bracket and axle tube. MIG weld a few beads on each side of the bracket. Finish it off with a little spray paint to keep it from rusting.