



Please read the following key points before installing this kit.

1 – Before performing the subframe connector installation, the vehicle must be completely assembled with all body and component parts installed (e.g. fenders, hood, quarterpanels, trunk, full interior, engine, glass, etc.). Basically, the subframe connectors should be one of the last components installed on your vehicle. Reason being is you want the vehicle settled with all of it's own final weight. The car's body is always in constant tension, with forces pushing or pulling within the chassis & body. You want to make sure these forces don't change after you install the subframe connectors. For example, if you installed subframe connectors before installing the engine and body panels this may result in having misaligned fenders, door panels and/or hood later on. The car must be in it's final state before the subframe connectors are installed.

2 – The subframe connectors must be installed on an alignment rack or floor ramps (all 4 wheels). The vehicle must be sitting on it's wheels at ride height in order to install the subframe connectors. Do not use a two-post lift, as this will load the chassis/body in the wrong points causing the chassis to tweak.

4014

Subframe Connectors 67-76 Chrysler A-Body



Subframe Connectors:

Your new subframe connectors will increase the overall rigidity of your chassis and improve handling and response. These engineered components connect the rear frame rails with the front subframe to simulate a complete full frame chassis.



Notes:

The subframe connector is essentially a Weld-In component, effectively connecting the front subframe and rear frame rails.

Before You Start:

The installation of these subframe connectors will require you to grind and weld. It is recommended that a trained professional install this product. Always wear eye protection when grinding or welding. Please read the entire manual before starting. All images will depict the driver side installation.

1. Raise Vehicle

It is best to install the subframe connectors at ride height. To do this properly, please use a 4-Post lift or alignment rack. Disconnect the negative battery cable.



2. Prepare Subframe Pieces for Welding

Subframe pieces come fully powder coated so you will want to first prep them for the welding process. Sand the front section and the rear mounting bracket where the parts will be welded.

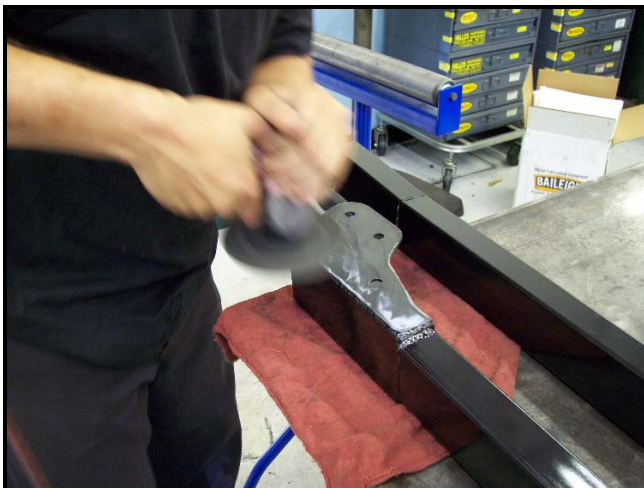

3. Trial Fit the Subframe Connectors

Before we weld anything we must first determine where we need to grind for welding and how the front mounting bracket is going to be positioned.

The front mounting point is located in-line with the front frame rails just outboard of the torsion bar rear mounting point. The rear mounting point is located at the front section of the rear frame rails. Grind and clean these areas as shown in the picture.

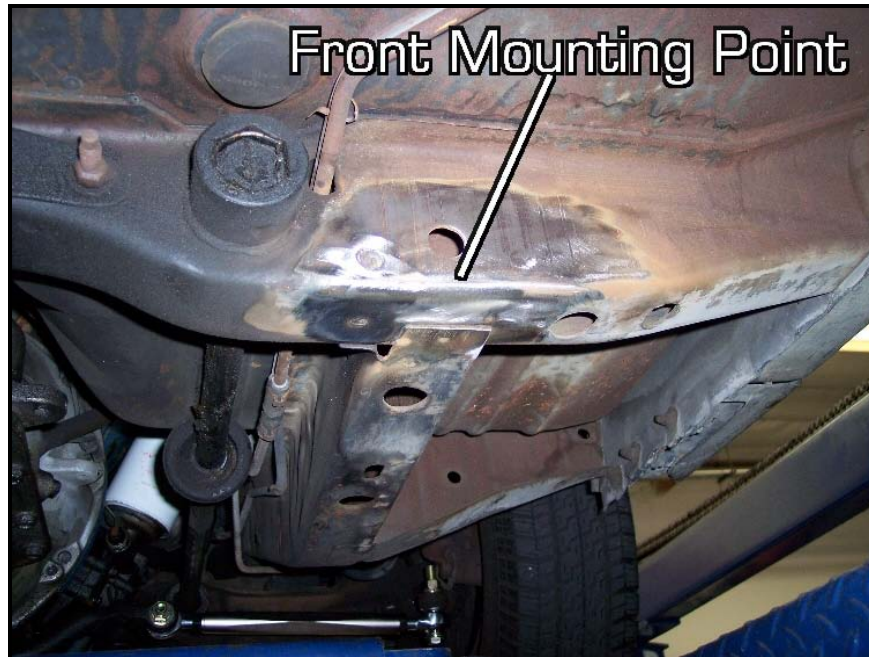

In some cases there may be a brake line tab on the driver side cross frame. It will be in the way of the Hotchkis front mount bracket. The line tab is not critical and can be removed. Unbolt the tab and push the brake line up and out of the way.



Grab one of the subframe connectors and position it onto the vehicle. Please note that there is a specific driver side and passenger side connector. Slide the rear bracket over the rear frame rails so that the bottom of the connector is somewhat flush with the bottom of the rear frame rail. See picture.

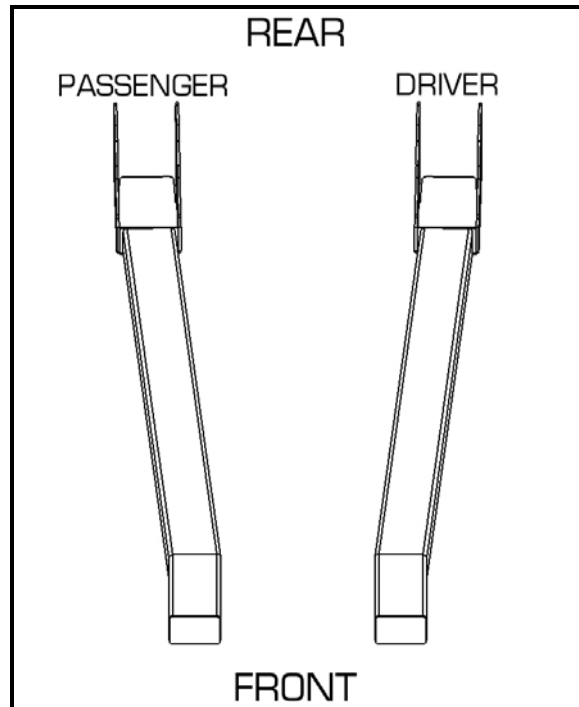

Install the front mounting bracket onto the front end of the connector. Mark the chassis to record the position of the front bracket.

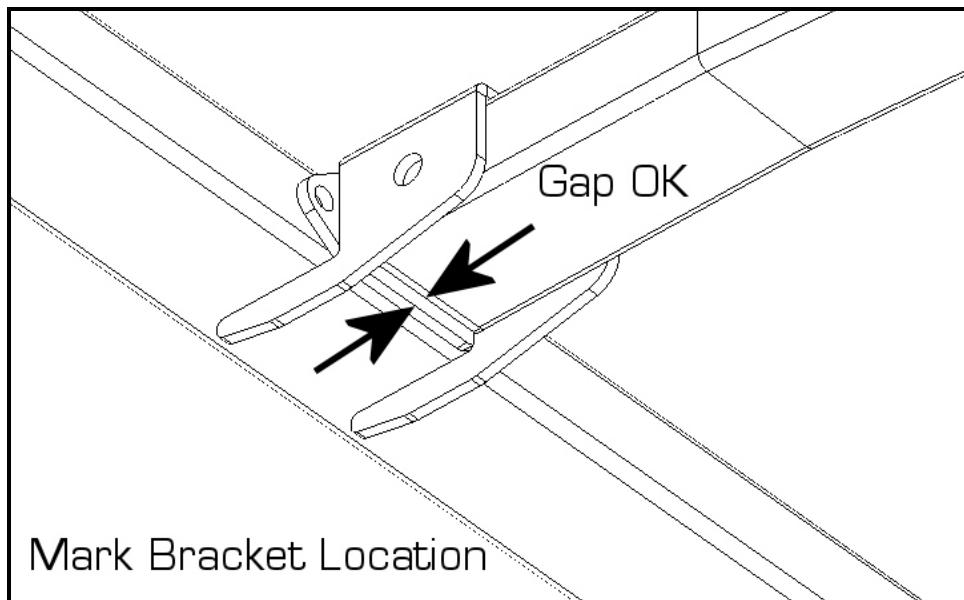
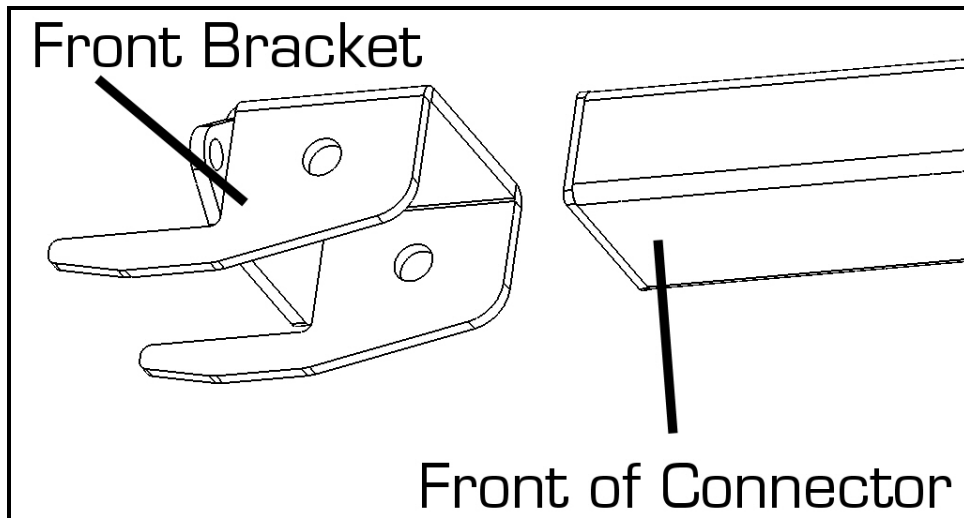

3. Welding the Front Mounting Bracket

Remove the connectors and reposition the front mounts to the chassis as marked. Tack-weld the front mount to the chassis. Double-check that the front mount is in the correct position by trial fitting the connector once more.

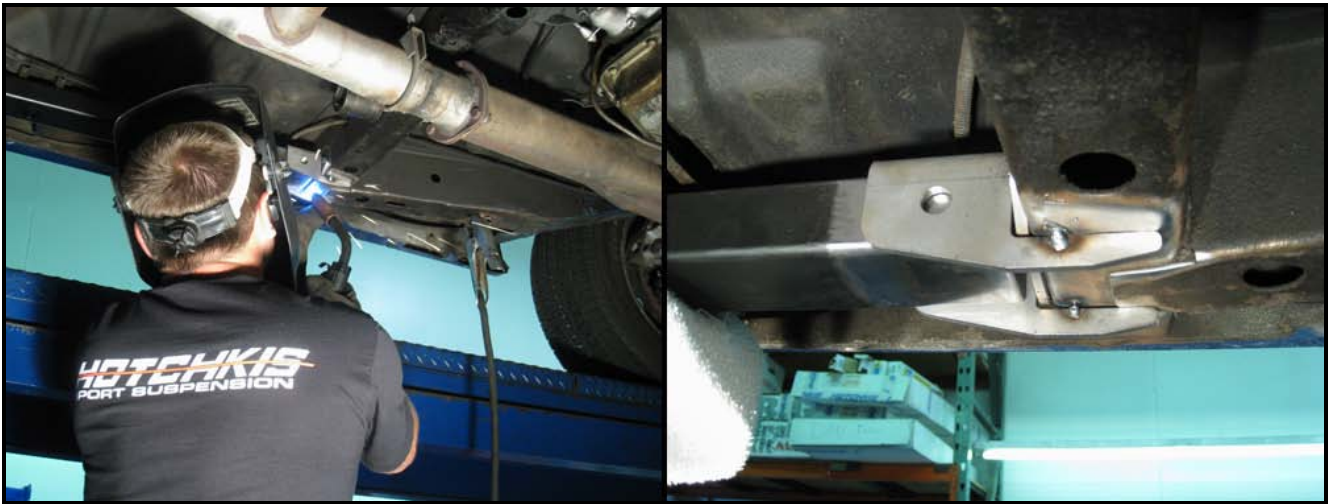

Once the position is confirmed weld the entire bracket to the frame.

WELDING POINTS

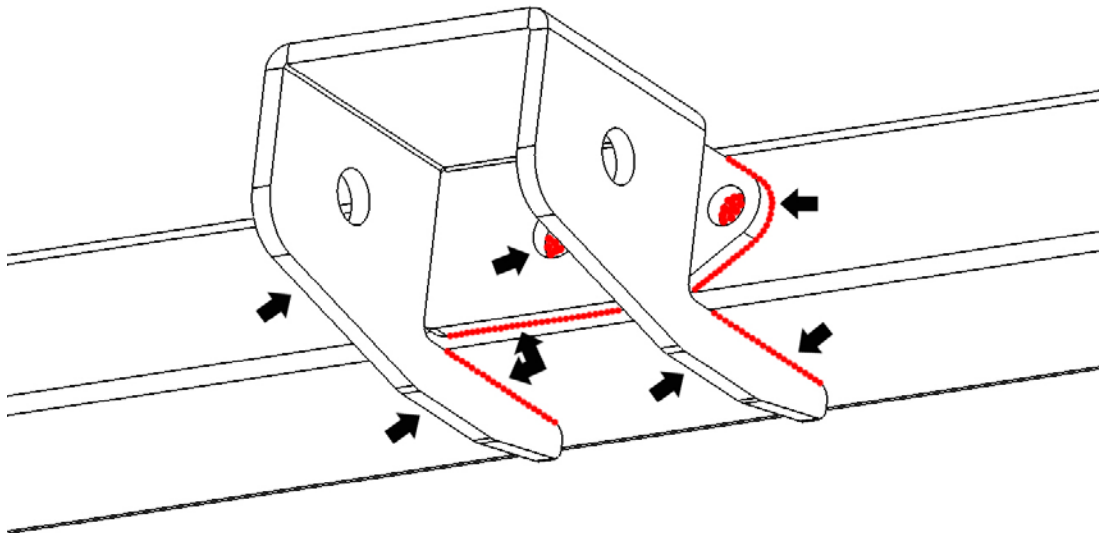

4. Weld in the Subframe Connector

Before welding, be sure that all of the surfaces that you will be welding is clean.

Use a screw jack to hold the subframe connector in place. Now weld the subframe connector to the front mounting bracket.

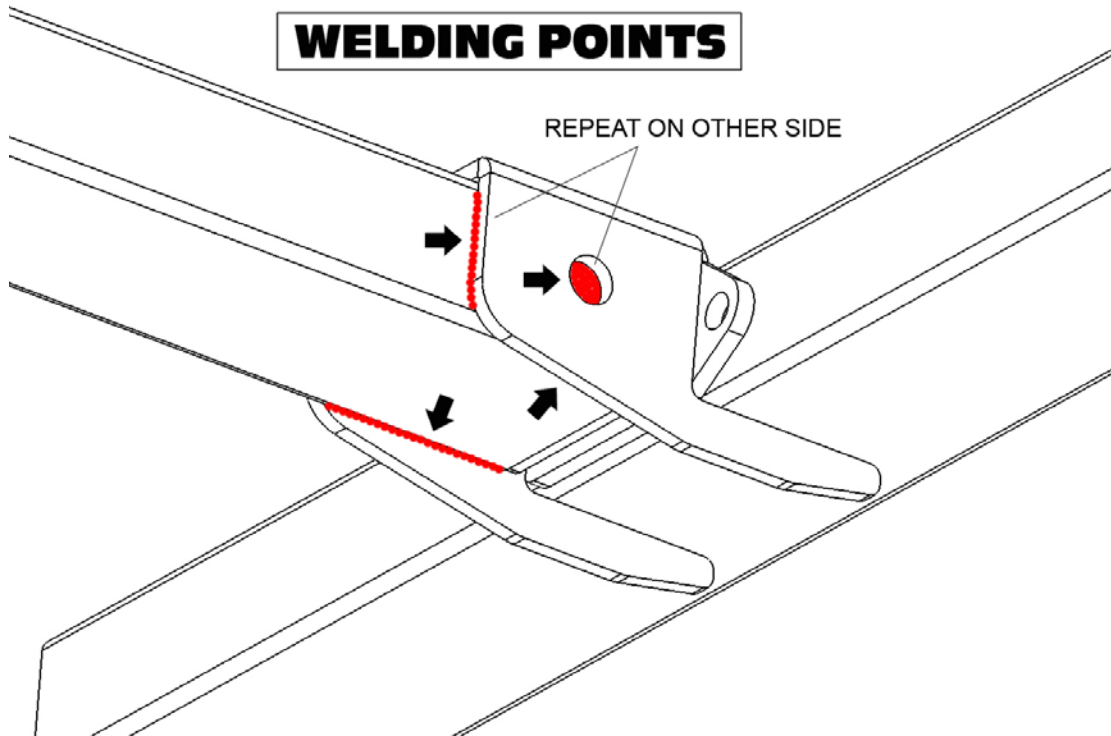

Next, weld the rear bracket to the rear frame rails. There are 4 rosette holes on each side of the rear mount. Rosette weld these holes and weld the rest of the mount as shown below. Repeat on other side of the bracket.

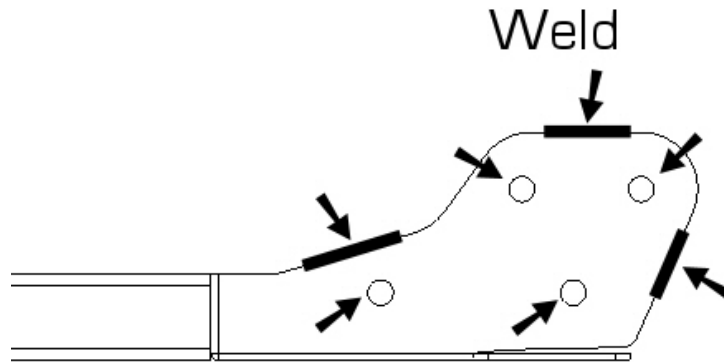

If you find that the rear section of the bracket has too much gap between the bracket and the frame rail, you can use vise grips to squeeze the sides together to take up the gap. Likewise, if you have too much gap between the bottom of the bracket and the bottom of the frame rail, then you can use a hammer to slightly bend the bottom portion of the bracket up to close the gap. The bracket was designed with reliefs at the bend area for this purpose.

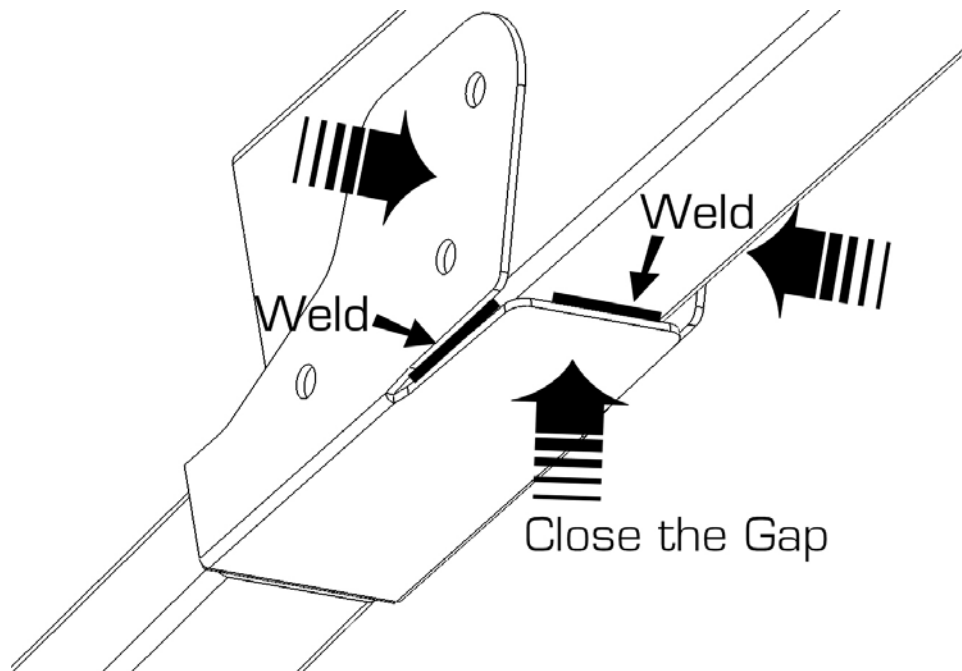

10. Paint

After the metal has cooled down, paint all exposed raw surfaces with a rust resistant paint.

