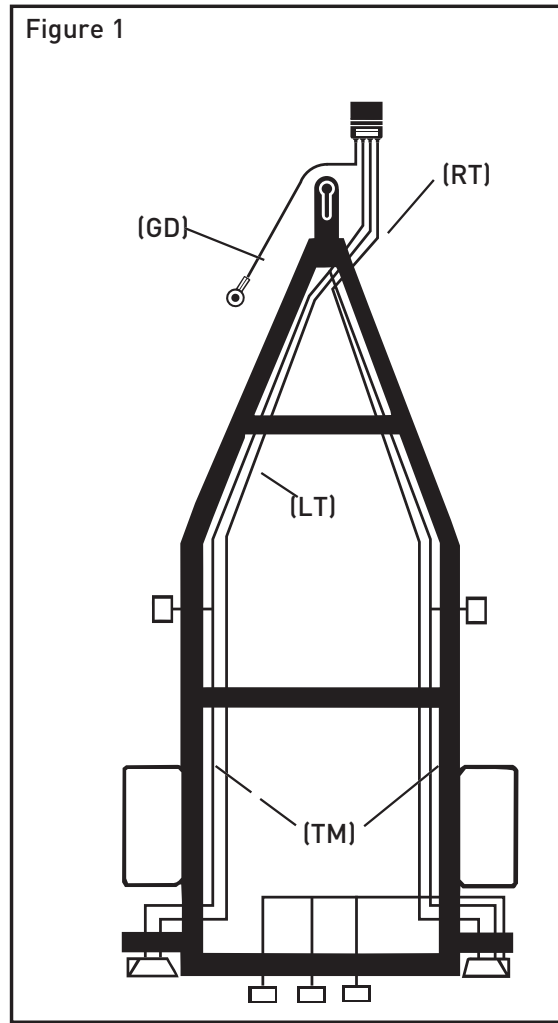

Figure 1



(GD) = Ground / White  
(LT) = Left Turn / Yellow  
(TM) = Taillight / Brown  
(RT) = Right Turn / Green

Y-Harness design eliminates secondary corrosion points making it easier to install with less cutting and splicing

To install on trailer:

1. Use a Circuit Tester to identify individual wires by function.
2. Attach wires of the 30 foot connector to the corresponding function wires as determined in Figure 1. Leave approximately 18 inches of slack between the trailer and the tow vehicle to allow the trailer to turn.
3. Attach ground to trailer frame with screw provided.
4. Test all functions to assure proper installation.

**NOTE:**

Identify wires by function only. Color coding is not standard with all manufacturers.

**TIPS:**

Grease applied to the trailer wiring terminals on a regular basis will help prevent corrosion.

A heavy duty flasher may be required to eliminate rapid flashing.

Always unplug boat trailer connector before backing trailer into the water.