



**P/N 6201HKR (Black) & 6201-1HKR (Ceramic)
SUPER COMPETITION FULL LENGTH CAR HEADERS
1970-71 Falcon, Fairlane (66 & up), Torino, Ranchero/Comet, Cyclone, Montego (429 CJ)
1971-73 Mustang/Cougar (429 CJ)**

Thank you for making HOOKER HEADERS your choice in a high-performance exhaust system. Extensive dyno/track testing has enabled HOOKER to offer the most advanced design in exhaust systems. The installation, while not complex, will take a certain amount of time. However, the additional horsepower and improved performance will more than justify your efforts. Proper installation and maintenance will ensure long life and maximum performance from your hooker exhaust system.

WARNING! Breaking in an engine with ceramic-coated headers WILL result in damage to the coating and will VOID all warranties. Ceramic-coated headers require several heat cycles to fully cure before they will withstand extreme heat. HOOKER recommends using a cast-iron exhaust manifold or an old header to break in new engines to avoid coating damage.

BEFORE STARTING

Your vehicle must be raised a minimum of 36 inches. A floor hoist is ideal. If no hoist is available, we strongly urge the use of axle stands as a safety measure. **CAUTION! YOUR CAR SHOULD NOT BE SUPPORTED ON A BUMPER JACK.**

NOTE: Will not fit with oil cooler.

NOTE: Will not fit with power steering (except on Mustangs & Cougars).

NOTE: Installation requires cutting hole in right side fenderwell.

NOTE: One tube over frame right side.

INSTALLATION PROCEDURE – PLEASE READ CAREFULLY

LEFT SIDE:

1. Disconnect battery cable to prevent damage to the car's electrical system.
2. Unbolt the headpipes from the exhaust manifolds and push aside.
3. Remove the clutch linkage, oil filter, spark plugs, and exhaust manifold.
4. Remove the L3 & L4 pipe from the main body of the header.
5. Starting from below, work the main body into position (do not start any bolts). With the header loose, work the L3 pipe into position and start the front bolt in the front section. Now, work the L4 pipe into position.
6. Remove the front bolt, place the gasket into position and start all bolts (most restricted first). between the header flange and exhaust port.
7. Tighten all bolts evenly.
8. Reinstall clutch linkage, oil filter, and spark plugs.

RIGHT SIDE:

1. Remove the spark plugs and exhaust manifold.
2. Use an air chisel or cutting torch to cut a hole in the fenderwell and remove the corner brace as per Figures 1 & 2.

NOTE: Mustang only – The smog can will be spot welded to the piece removed from the fenderwell. Separate the smog can from the fenderwell segment and relocate directly above the hole in the fenderwell.

3. Starting from below, work the main body of header (the two front pipes) into position and start the front bolt. With the header loose, work the R3 pipe into position. Work the R4 pipe through the hole in the fenderwell and into slip tube.
4. Remove the front bolt, place the gasket into position and start all bolts (most restricted first).
5. Tighten all bolts evenly.

NOTE: Check the transmission cooler lines and make sure they do not come in contact with the header.

6. To connect the collectors to the headpipes, purchase Hooker Header reducer kit 11035HKR. Bolt reducers (with gasket) to collectors. Line up headpipes, cut to the correct length, and weld to the reducers.
7. Connect the battery, start the engine, and check for leaks. Be sure all brake lines, fuel lines, transmission cooler lines, and electrical wires have sufficient clearance. Reroute, as necessary.

8. When finished, give your vehicle a test drive, checking for any new noises. After several days of driving, retighten all bolts.

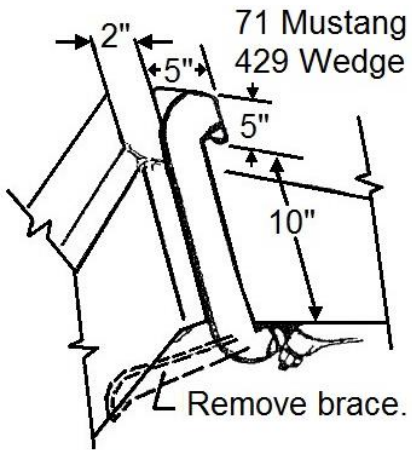

Cut hole in fenderwell for R4 pipe.

Figure 1

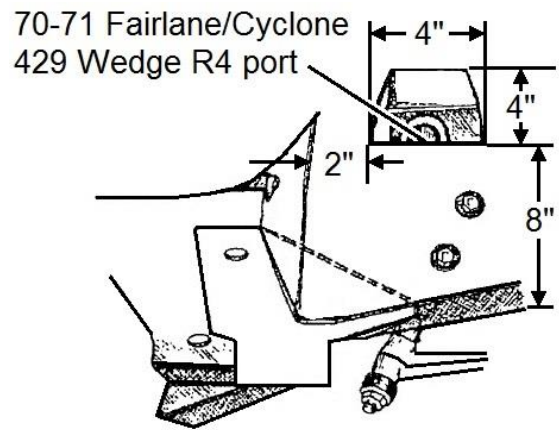

Cut hole in fenderwell for R4 pipe.

Figure 2