



**2460HKR (Painted), 2460-1HKR (Silver Ceramic),
2460-2HKR (Stainless), 2460-3HKR (Darkside Black Ceramic), &
2460-4HKR (Titanium)**

**COMPETITION CHEVY/GMC HEADERS
1982-92 Camaro (265-400) & 1982-92 Firebird, Trans Am (265-400CH)**

NOTE: Aluminized "Y" pipe that bolts to factory or aftermarket cat-back is available under P/N 16767HKR.

Thank you for making HOOKER HEADERS your choice in a high-performance exhaust system. Extensive dyno/track testing has enabled HOOKER to offer the most advanced design in exhaust systems. The installation, while not complex, will take a certain amount of time. However, the additional horsepower and improved performance will more than justify your efforts. Proper installation and maintenance will ensure long life and maximum performance from your hooker exhaust system

WARNING! Breaking in an engine with ceramic-coated headers WILL result in damage to the coating and will VOID all warranties. Ceramic-coated headers require several heat cycles to fully cure before they will withstand extreme heat. HOOKER recommends using a cast-iron exhaust manifold or an old header to break in new engines to avoid coating damage.

NOTE: Will fit with angle plug heads.

NOTE: This header is equipped with a fitting to accept the stock oxygen sensor.

BEFORE STARTING

Your vehicle must be raised a minimum of 36 inches. A floor hoist is ideal. If no hoist is available, we strongly urge the use of axle stands as a safety measure.

CAUTION! YOUR CAR SHOULD NOT BE SUPPORTED ON A BUMPER JACK.

INSTALLATION PROCEDURE – PLEASE READ CAREFULLY

RIGHT SIDE:

1. Remove the oil dipstick tube, alternator (on early cars), A/C (on later models), diverter valve, air injection manifold, and exhaust manifold.
2. Remove the right side motor mount bolt and jack the motor up approximately 1-1/2" to 3".

CAUTION! Be sure to place a board between the oil pan and the jack. Check to make sure the fan doesn't contact the shroud (82-84 models).

3. Starting from above, work the header down into position. DO NOT start the header bolts yet.
4. Lower the motor and check for header clearance. (On some later models, the heater line will need to be repositioned to gain clearance.)
5. Replace the motor mount bolt. Install the gasket and start the most restrictive header bolts first.
6. Reinstall the dipstick tube and tighten all bolts evenly.
7. Install the spark plugs and plug wires.

LEFT SIDE:

1. Remove the air conditioning compressor (on early cars), alternator brace (on later models), air injection manifold, all brackets attached to the exhaust manifold, and the exhaust manifold.
2. On computer controlled cars, drill through the bushing on the collector with a 9/16" drill bit. Clean the edges of the hole with a file and install the O₂ sensor.
3. Starting from above, work the header down into position. With the gasket in place, start the bolts (most restricted first).
4. Modify the air conditioning bracket (Figure A). Install the bracket using the stock stub and tubular spacers provided.
5. Tighten all fasteners evenly (most restricted first).
6. Install the spark plugs and plug wires.
7. To connect the headers to the exhaust, purchase a Hooker reducer kit, P/N 11030HKR.
8. Connect the battery, start the engine, and check for leaks. Be sure all brake lines, fuel lines, transmission cooler lines, and electrical wires have sufficient clearance. Reroute as necessary.

NOTE: A dual exhaust system can be fabricated, using Hooker Competition Turbos P/N 21005HKR or 21006HKR and a universal tailpipe.

9. When finished, give your vehicle a test drive, checking carefully for any new noises. After several days of driving, retighten all bolts.

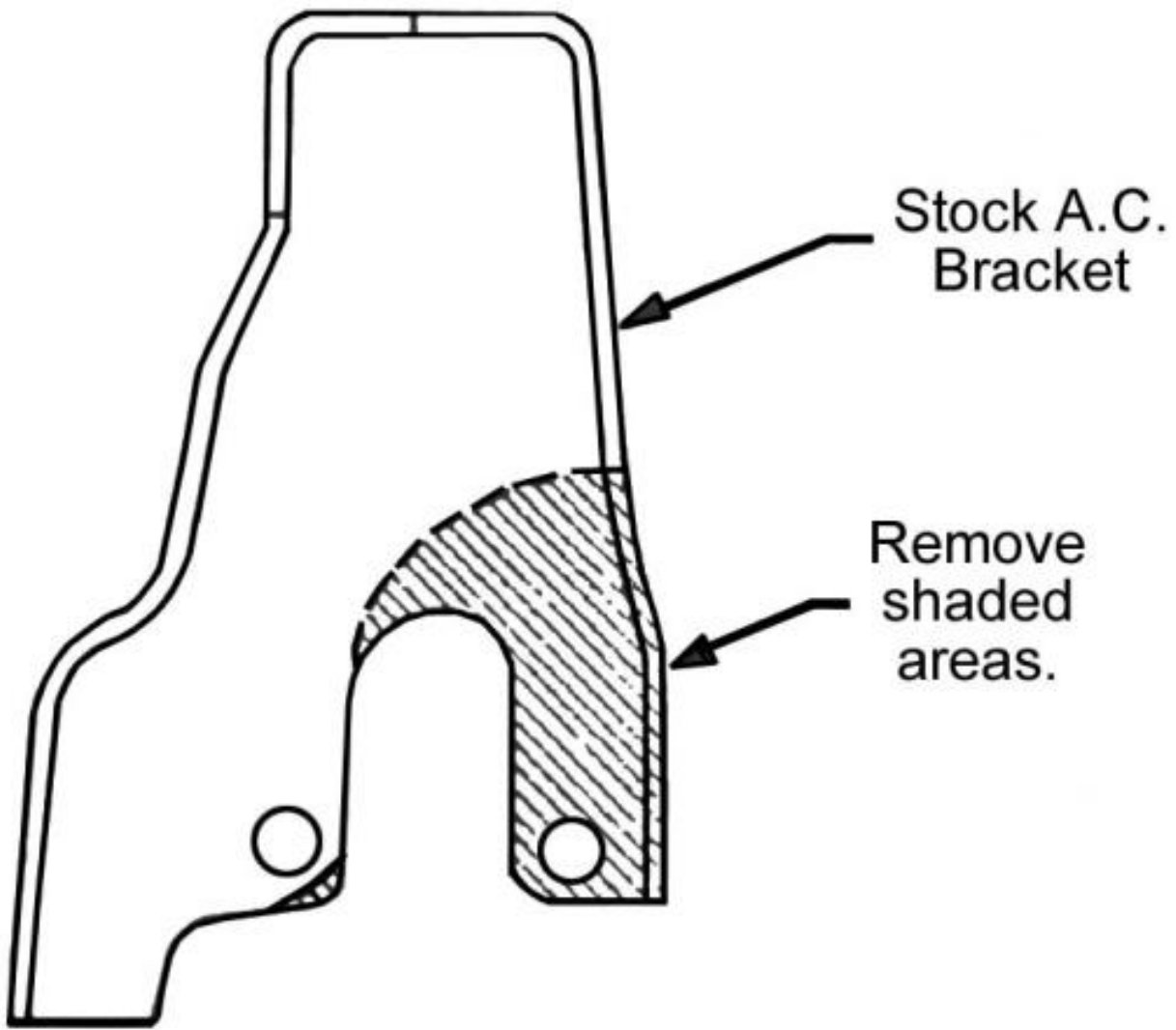

Figure A