



**2455HKR (Black Paint), 2455-1HKR (Silver Ceramic),
2455-2HKR (Stainless), 2455-3HKR (Darkside black ceramic), & 2455-4HKR (Titanium)**

**Competition Header for 70-72 Chevy Camaro, 64-74 Chevelle/El Camino/Caballero/Sprint,
70-74 Monte Carlo, & 71-74 Passenger Car/Wagon**

Instruction Sheet

NOTE: This will not fit with a manual transmission on the Monte Carlo or late passenger/wagon models and will also not fit on Camaros with a column shift.

BEFORE STARTING

Your vehicle must be raised a minimum of 36 inches. A floor hoist is ideal. If no hoist is available we strongly urge the use of axle stands as a safety measure.

CAUTION! Your car should not be supported on a bumper jack prior to installing headers, take the time to make a careful and complete inspection of both engine and transmission mounts. Replace them if they look worn or damaged, otherwise this may affect the header fitting into your vehicle properly.

HEADER INSTALLATION PROCEDURE/ DISASSEMBLY & ASSEMBLY INSTRUCTIONS **PLEASE READ THOROUGHLY & CAREFULLY**

LEFT SIDE

1. Disconnect the battery cable to prevent damage to the electrical systems.
2. Unbolt the headpipe from the stock exhaust manifold and push aside.
3. Remove the spark plugs, oil filter, clutch linkage (if so equipped), center motor mount bolt, air conditioning (if mounted on left side), and power steering (if mounted on head).

NOTE: On some models, it will be necessary to bend the frame support rod to clear the headers, or remove it. See **Figure A**.

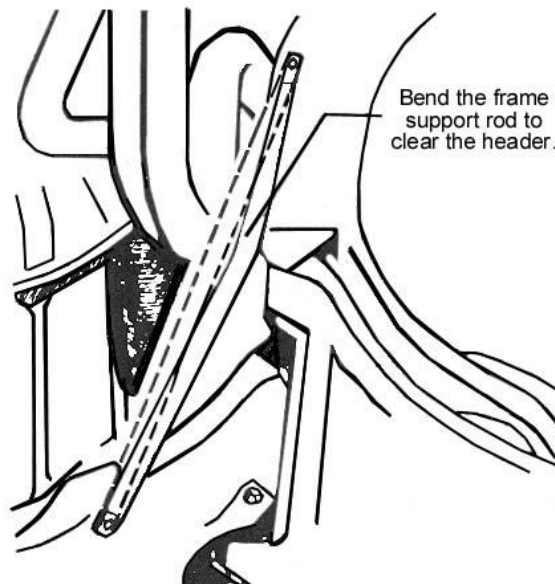

Figure A

NOTE: Some models require the brake line block to be relocated from the side of the frame to the top of the frame to provide maximum clearance for the header.

4. Place a board under the oil pan and jack up the engine approximately 2 inches.
5. Starting from below, work the header up through the chassis into position.

NOTE: It may be necessary to modify the motor mount, according to **Figure B**, if the L-1 pipe does not have sufficient clearance.

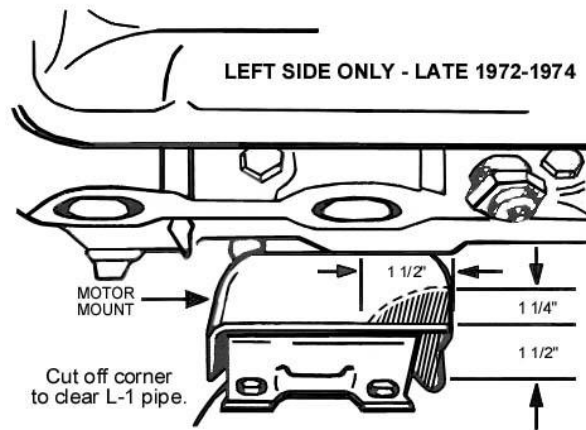

Figure B

6. Lower the engine and replace the motor mount bolts.
7. Position the gasket and start all bolts. Tighten all bolts evenly.
8. Replace the spark plugs, oil filter, and clutch linkage (if removed).
9. To remount the air conditioning, modify the stock bracket. 1964-72 models: see **Figure C**. 1973-74 models: see **Figure D**.

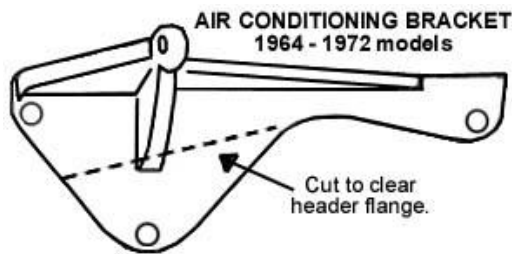

Figure C

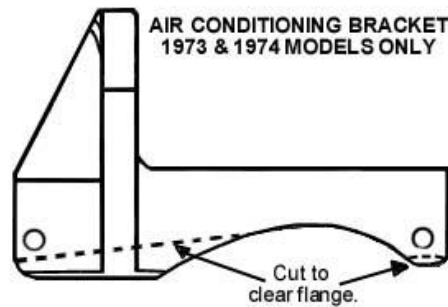

Figure D

NOTE: Some 1968 models will require a fabrication of a 3/4" spacer for the power steering mounting bolt. See **Figure E**.

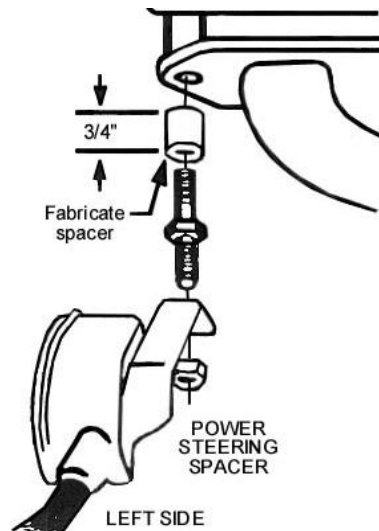

Figure E

RIGHT SIDE

1. Remove the spark plugs, dipstick tube, stock exhaust manifold, and air conditioning (if mounted on right side).
2. Starting from below, work the header up through the chassis into position. Check the clearances.

NOTE: It may be necessary to increase clearances. 1) Bend or remove the frame support brace. See **Figure A**. 2) Trim A-frame bolts flush with the nuts. See **Figure F**. 3) Slightly dent the header pipe R-2 according to **Figure G** (this modification will not affect performance).

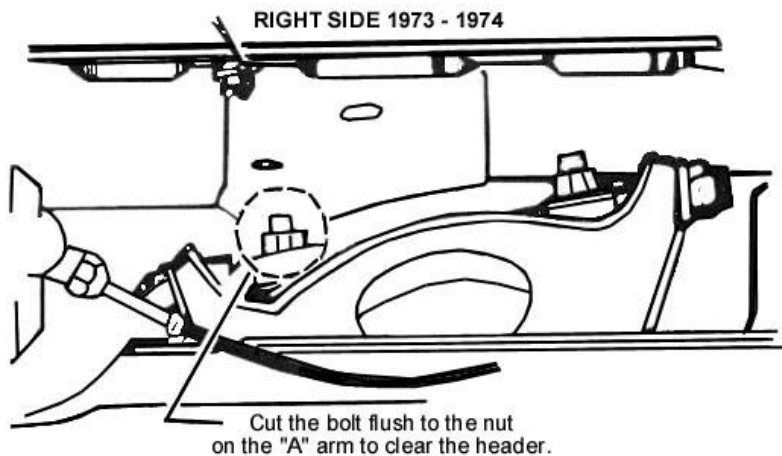

Figure F

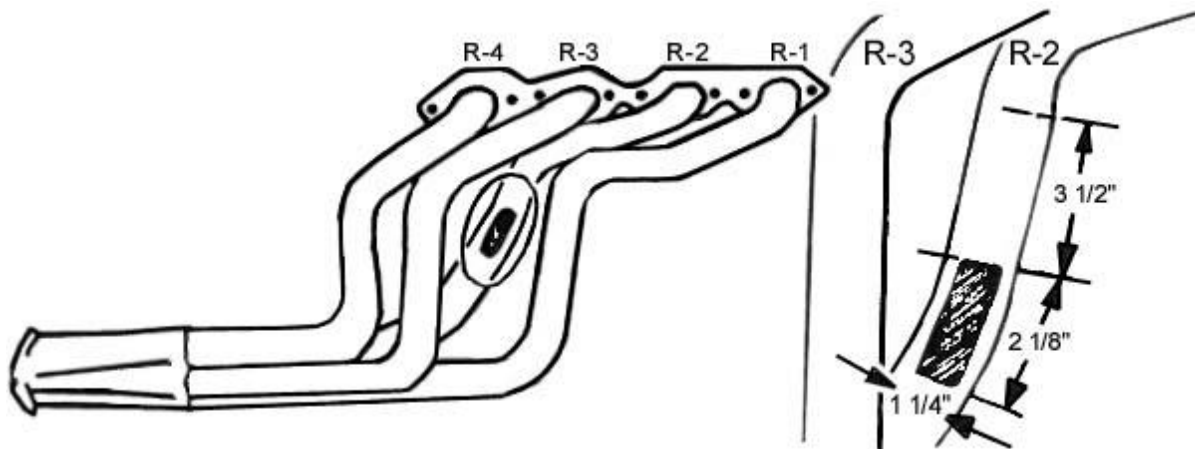

Figure G

3. Position the gasket and start all bolts. Tighten all bolts evenly.
4. For models with automatic transmissions, check the cooler lines for header clearance. Reroute, as necessary.
5. Replace the spark plugs and dipstick tube.
6. For models equipped with air conditioning mounted on the right side, it is required to modify the mounting bracket for header clearance. Fabricate two spacers (3/8" approximately) and install using two stock exhaust manifold bolts. See **Figure H**.

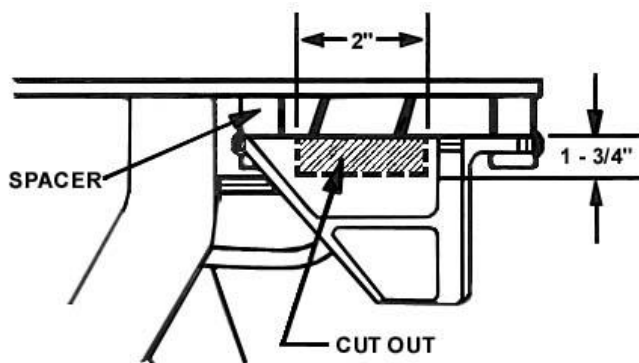

Figure H

