



## Super Competition Full Length Car Headers 2122HKR (black) & 2122-1HKR (ceramic) 1962-67 Chevy II / Nova (283-327)

**NOTE:** This header was designed to be used with the original Chevy II V8 block, bellhousing, and clutch linkage. Header will also fit Chevy II with Lakewood bellhousing #15050. For the transplant or anything other than original Chevy II equipment, we recommend #2214HKR or 2243HKR.

**NOTE:** Will fit heads with factory plug angle.

**NOTE:** Will not fit with Edelbrock angle plug heads.

Thank you for making HOOKER HEADERS your choice in a high-performance exhaust system. Extensive dyno/track testing has enabled HOOKER to offer the most advanced design in headers for your application. Due to the restricted room available in the engine compartment, your headers may be close to some body and chassis components. This condition is normal. The installation, while not complex, will take a certain amount of time. However, the additional horsepower and improved performance will more than justify your efforts. Proper installation and maintenance will ensure long life and maximum performance from your hooker exhaust system.

### BEFORE STARTING

Your vehicle must be raised a minimum of 36 inches. A floor hoist is ideal. If no hoist is available we strongly urge the use of axle stands as a safety measure. **CAUTION!** Your car should not be supported on a bumper jack prior to installing headers, take the time to make a careful and complete inspection of both engine and transmission mounts. Replace them if they look worn or damaged, otherwise this may affect the header fitting into your vehicle properly.

### INSTALLATION PROCEDURE – PLEASE READ CAREFULLY!

#### LEFT SIDE:

1. Disconnect the battery cable to prevent damage to the electrical system.
2. Unbolt the stock headpipes from the exhaust manifolds and push aside.
3. Remove the alternator, spark, plugs, exhaust manifold, and dipstick tube.

**NOTE:** For the ease of installation, the flange has been cut between the #3 and #4 tubes and the clutch linkage does not have to be removed.

4. Starting from below, work the header up through the chassis (clutch cross shaft slips through where flange is cut) into position.
5. Place the gasket into position and start all bolts, except the front bolts. This where your bolt-on alternator bracket is to be installed.
6. Tighten all bolts evenly.

**NOTE:** Remove the alternator bracket from the stock exhaust manifold. Bolt this bracket to the one on your header. If the bracket is cast iron, see **Figure A** for modification. The stamped steel bracket will not need any modification. Install brackets per **Figure B**.

7. Reinstall the spark plugs, dipstick tube, and alternator.

#### RIGHT SIDE:

1. Remove the exhaust manifold, spark plugs, starter, and air conditioning compressor (if equipped).
2. Starting from below, work the header and the starter up through the chassis into position. Place the gasket into position and start all bolts (most restricted first).
3. Tighten all the bolts evenly.
4. Replace the starter and spark plugs.
5. To connect the collectors to the headpipes, purchase Hooker reducer kit, P/N 11030HKR.

**NOTE:** A dual exhaust system can be fabricated using the HOOKER comp turbo (21005HKR or 21006HKR).

6. Connect the battery, start the engine, and check for leaks. Make sure all brake lines, fuel lines, transmission cooler lines, and electrical wires have sufficient clearance. Reroute, as necessary.
7. When finished, give your car a test drive, checking carefully for any new noises. After several days of driving, retighten all bolts.

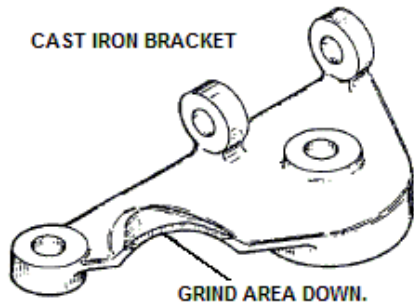

**Figure A**

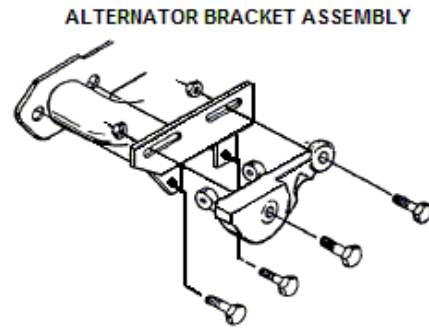

**Figure B**

#### **LIMITATION OF LIABILITY – DISCLAIMER**

The regulation of emissions production, noise levels, and safety standards is undertaken by the federal government, each of the fifty state legislatures, and by many local municipalities, towns, and counties.

HOKKER Industries makes no warranties of merchantability, of fitness for particular purpose, or that its products are approved for general use, or that its products comply with laws, regulations, or ordinances in the states where they may be sold to the ultimate purchaser, the consumer.

Unless expressly stated to the contrary in the catalog, instruction sheet, or price list, the entire risk as to the conformity of any company product in any such state and as to repair should the product prove to be defective or nonconforming, is on the retail purchaser, the buyer, the ultimate consumer, of such product and it is not upon the seller, distributor, or manufacturer.

In this connection, the retail purchaser, the buyer, the ultimate consumer assumes the burden of the entire cost of any and all necessary service, alterations, or repair.

**The foregoing statement limits the liability of the manufacturer.**

California vehicle code, sections 27156 and 38391, prohibits the advertising, offering for sale, or installation of any device, which modifies a vehicle's emission control system, unless exempted, unless otherwise noted. HOKKER Headers that have not received an Executive Order (E.O.) exemption from these code sections are not legal for sale or use in California on vehicles originally equipped with catalytic converters, except for racing vehicles, which may never be driven upon a highway. Check with your local authorities to determine if these headers are legal for use in your particular area.