



**16561HKR (header back)
16661HKR (manifold back)
1978-79 4WD Bronco, F-150, F-250 (Low Profile), & F-350
COMPETITION EXHAUST SYSTEM**

- NOTE:** Front differential pinion is above centerline of axle.
- NOTE:** Dual kit runs down right hand side between frame and driveshaft.
- NOTE:** P/N 16561HKR header dual system was designed to be used with Hooker Competition P/N 6902HKR headers. If the dual exhaust is being installed with headers other than the P/N listed above, modifications will be required. Hooker Headers will not assume responsibility for fit or performance.
- NOTE:** Mufflers are not supplied with this exhaust system. Hooker Headers has designed this kit for use with Hooker Turbo Muffler 21005HKR, 21105HKR, or equivalent 2 1/4" ID inlet by 2 1/4" ID outlet single offset OEM Muffler.

BEFORE STARTING:

Your vehicle must be raised a minimum of 36 inches. A floor hoist is ideal. If no hoist is available, we strongly urge the use of axle stands as a safety measure. **CAUTION! Your car should NOT be supported on a bumper jack!** We recommend welding all pipe slip joints (headpipe to muffler, etc.). If no welding equipment is available at the time of installation, use the furnished clamps to secure the pipes until they can be welded.

INSTALLATION PROCEDURE – PLEASE READ CAREFULLY:

1. Remove the existing headpipe crossover and single exhaust system. Cut the headpipe and remove the flanges. Use these flanges on the new headpipes.
2. Install the left side headpipe using the old flanges. Tighten only enough to hold in place. Slip the left side headpipe extension over the headpipe, rotate into position, and use 2 1/4" U-clamp. Do not tighten completely. On header duals, install the left side headpipe, using the collector gaskets provided. Do not tighten. See Figure A for headpipe location.
3. Install the left and right side extensions using 2 1/4" U clamps. Use the strap with 3 holes for spacing between headpipes. See Figure A. Do not use extensions on the Bronco. Due to the wheelbase, it may not need them.
4. Install the mufflers on the end of the extensions. If you should use a longer muffler, measure and cut the difference in length out of these sections. Put clamps over muffler slips, but do not tighten. Rotate mufflers to clear driveshaft and frame (See Figure A). Over the rear of the mufflers, you will find a crossmember that a hole can be drilled to accept a 5/16" bolt, 90° bracket, and rubber hanger. On some models, remove the stock rubber hanger and spring bracket from the rear crossmember. Save and use the stock Ford Bracket (P/N D8TA-5A246-AB) on the frame and bolt the rubber hanger supplied with a 5/16" bolt, washer, and nut to it (See Fig. A). Then, clamp to the outlet side of the muffler. Do not tighten.
5. Install the front tailpipe extension, left and right.
NOTE: This kit is designed to fit pickups with a 133" wheelbase. Should your pickup have a shorter wheelbase, but longer than a Bronco, it will be necessary to remove length. This can be done by cutting it out of the straight section going into the front of the mufflers.
6. Install tailpipes and center bump over the rear axle housing for maximum clearance. (See Figure A, left side tailpipe crosses over.)
7. As the tailpipe goes under the frame on its way out to the rear of the vehicle, find a hole in the area, or drill a hole, to bolt the bracket and rubber grommets. This bracket is the 90° with a large hole to accept the male and female grommets, large washers, 5/16" bolts, lockwashers, and nuts.
8. Make sure that all parts of the system are clear of frame members, all hoses, suspension, and bracket lines. Starting at the exhaust manifolds or header, tighten all connections, making sure all parts are clear and will not leak or rattle.
9. Start the engine and check for leaks. Be sure that all brake lines, fuel lines, and electrical wires have sufficient clearance. Reroute as necessary.
10. When finished, give your car a test drive, checking carefully for any new noises. After several days of driving, retighten all the bolts.

LIMITATION OF LIABILITY – DISCLAIMER:

The regulation of emissions production, noise levels, and safety standards is undertaken by the federal government, each of the fifty state legislatures, and by many local municipalities, towns, and counties.

HOOKER makes no warranties of merchantability, of fitness for particular purpose, or that its products are approved for general use, or that its products are approved for general use, or that its products comply with laws, regulations, or ordinances in the state where they may be sold to the ultimate purchaser, the consumer.

Unless expressly stated to the contrary in the catalog, instruction sheet; or price list, the entire risk as to the conformity of any company product in any such state and as to repair should the product prove to be defective or non-conforming, is on the retail purchaser, the buyer, the ultimate consumer, of such product and it is not upon the seller, distributor, or manufacturer.

In this connection, the retail purchaser, the buyer, the ultimate consumer assumes the burden of the entire cost of any and all necessary service, alterations, or repair.

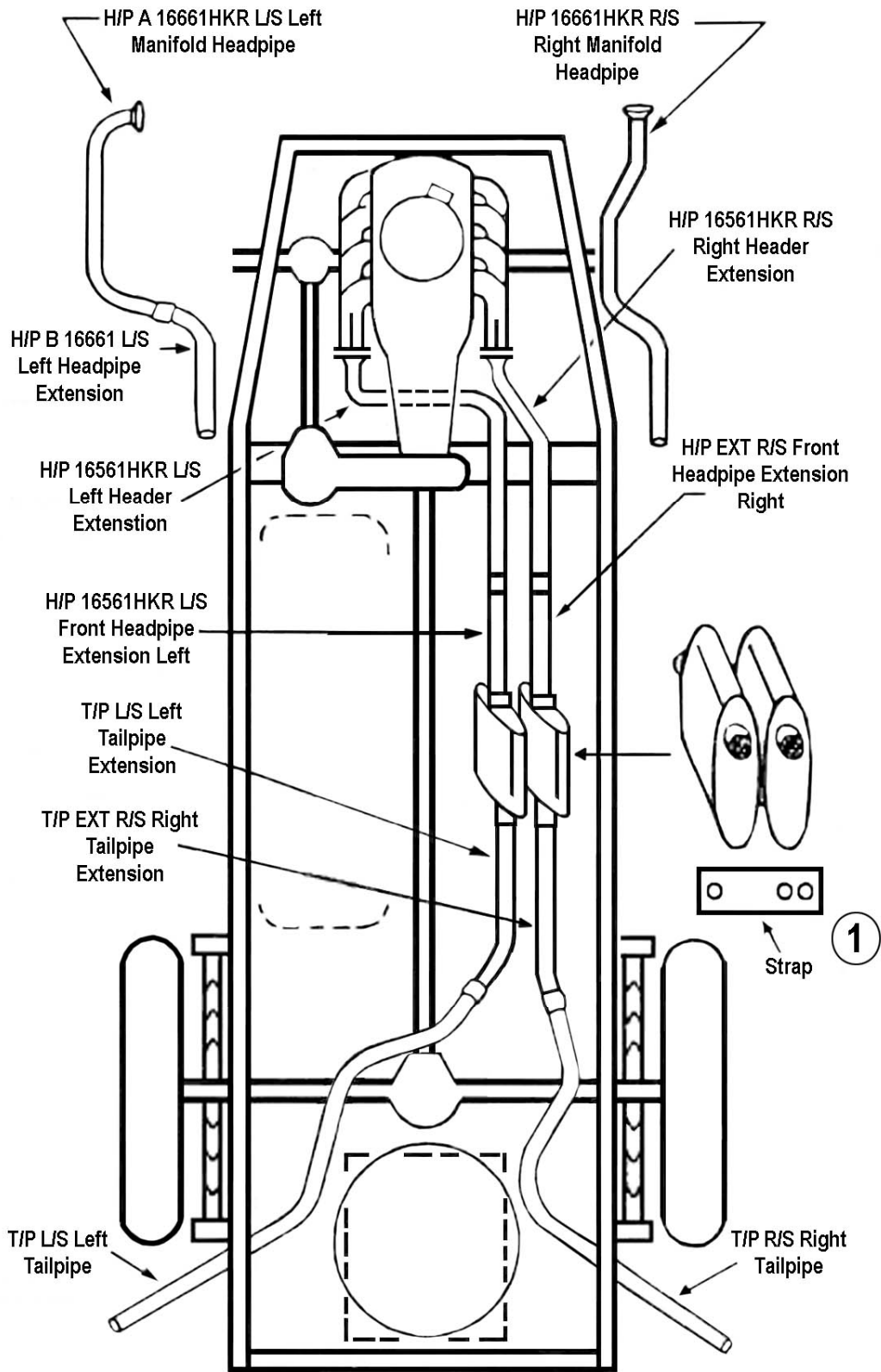

① Install mufflers side by side in this position with center inlet in front. Use 3-hole straps & U-clamps for proper clearance between mufflers & pipes.

Figure A