



## P/N 1103HKR (Painted) & 1103-1HKR (Ceramic-Coated) SUPER COMPETITION FULL LENGTH CAR HEADERS

BUICK: 1973-76 Century, Regal, Wagons, 1968-72 Skylark, Gran Sport, & Wagons (350)

OLDSMOBILE: 1975 Omega (Buick 350)

PONTIAC: 1975 Ventura, Phoenix, & 1974 GTO (Buick 350)

Thank you for making HOOKER HEADERS your choice in a high-performance exhaust system. Extensive dyno/track testing has enabled HOOKER to offer the most advanced design in exhaust systems. The installation, while not complex, will take a certain amount of time. However, the additional horsepower and improved performance will more than justify your efforts. Proper installation and maintenance will ensure long life and maximum performance from your hooker exhaust system.

**WARNING! Breaking in an engine with ceramic-coated headers WILL result in damage to the coating and will VOID all warranties. Ceramic-coated headers require several heat cycles to fully cure before they will withstand extreme heat. HOOKER recommends using a cast-iron exhaust manifold or an old header to break in new engines to avoid coating damage.**

### **BEFORE STARTING**

Your vehicle must be raised a minimum of 36 inches. A floor hoist is ideal. If no hoist is available, we strongly urge the use of axle stands as a safety measure.

**CAUTION! YOUR CAR SHOULD NOT BE SUPPORTED ON A BUMPER JACK.**

### **INSTALLATION PROCEDURE – PLEASE READ CAREFULLY**

#### **LEFT SIDE:**

1. Disconnect the battery to prevent damage to the electrical system.
2. Unbolt the stock headpipes from the exhaust manifolds and push aside.
3. Remove the exhaust manifold (with its heat shield) and dipstick tube. On 1976 models, remove the frame support rod.
4. Starting from below, work the header up through the chassis into position over the exhaust ports.
5. Slip the flange gasket into place and start all header bolts (most restricted first).
6. Replace the dipstick tube. Models with a two-piece tube must modify its mounting bracket (See Figures A, B, & C) to reinstall the dipstick tube. 1976 models with two-piece tubes may not require the above modifications.
7. Replace the frame support rod (if removed). All vehicles may require bending rod as needed for header clearance (See Figure D).
8. Tighten all header bolts evenly.
9. Reinstall stock heat stove and hose in original location.

#### **RIGHT SIDE:**

1. Remove the stock exhaust manifold and its heat shield. Remove the frame support rod.
2. Starting from below, work the header up through the chassis components. 1976 models may require starter removal.
3. Position the flange gasket first, then header, over the exhaust ports. Start header bolts (most restricted first).
4. Tighten all bolts evenly. Replace the frame support rod, bending as needed for header clearance. See Figure D.
5. Replace starter (if removed). Reroute the automatic transmission cooling lines so they run directly under the starter.
6. Either eliminate or modify the exhaust manifold heat shield for maximum clearance on the starter and header.

**NOTE:** 1975 Pontiac Venturas: In park position, if shift linkage hits the collector, it may be necessary to bend the collector and headpipes slightly to the left.

7. To connect collectors to stock headpipes, purchase Hooker Header Reducer Kit (P/N 11030HKR). Bolt reducers (with gasket) to the collectors, line up headpipes, cut to correct length, and weld to reducers.
8. Connect the battery, start the engine, and check for leaks. Be sure all brake lines, fuel lines, transmission cooler lines, and electrical wires have sufficient clearance. Reroute, as necessary.
9. When finished, give your vehicle a test drive, checking carefully for any new noises. After several days of driving, retighten all bolts.

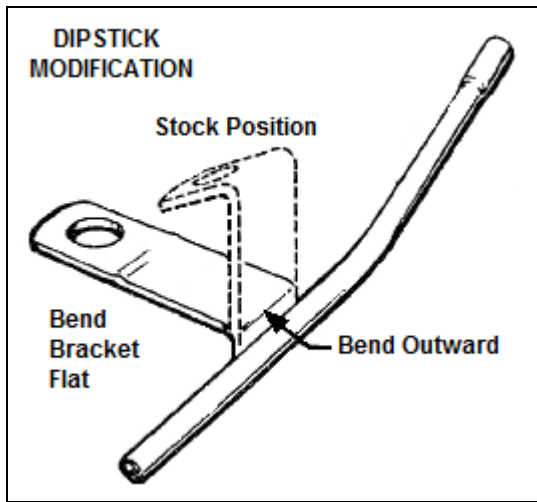

Figure A

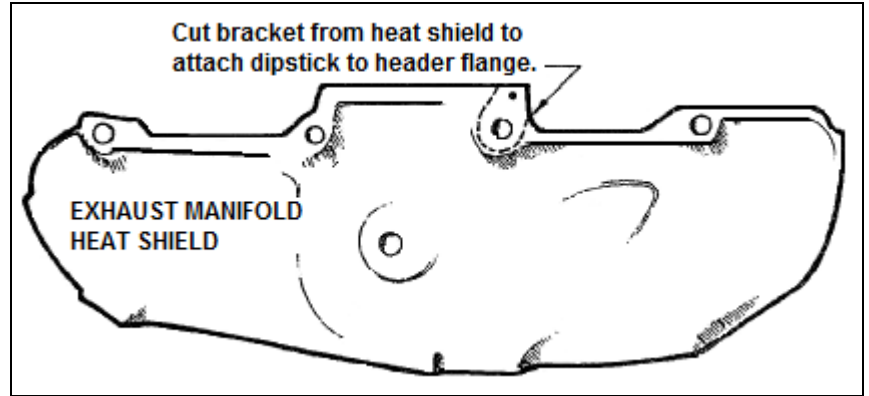

Figure B

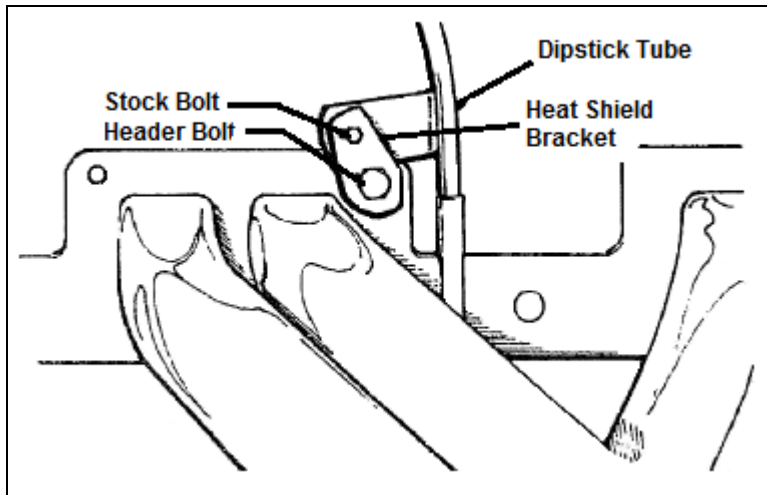

Figure C

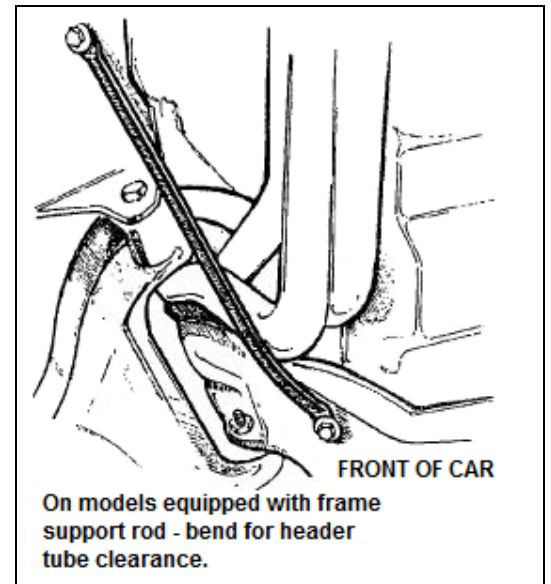

Figure D