



**HOOKER COMPETITION EXHAUST SYSTEMS**  
**P/N 7501HKR (header back) & 7504HKR (manifold back)**  
1975-91 Blazer, Suburban/Jimmy, Carryall, Yukon, 1-Ton Crew (2WD) 265-400  
1975-87 1/2, 3/4, 1-Ton Truck (2WD) 265-400

**WARNING!** Breaking in an engine with ceramic-coated headers **WILL** result in damage to the coating and will **VOID** all warranties. Ceramic-coated headers require several heat cycles to fully cure before they will withstand extreme heat. **HOOKER** recommends using a cast-iron exhaust manifold or an old header to break in new engines to avoid coating damage.

**NOTE:** P/N 7501HKR was designed to be used with 2452HKR headers. If the dual exhaust is being installed with headers other than the 2452HKR header, some modifications will be required. Hooker Headers will not assume responsibility for fit or performance.

**NOTE:** Mufflers are not supplied with this exhaust system. Hooker Headers has designed this kit for use with Hooker Turbo muffler P/N 21005HKR or any equivalent 2 1/4" I.D. inlet by 2 1/4" I.D. outlet single offset OEM muffler. Glasspack mufflers may be used with slight modifications.

**NOTE:** Models with more than a 131.5" wheelbase must order a tailpipe extension kit.

**BEFORE STARTING:**

Your vehicle must be raised a minimum of 36 inches. A floor hoist is ideal. If no hoist is available, we strongly urge the use of axle stands as a safety measure. **CAUTION! Your vehicle should NOT be supported on a bumper jack!** We recommend welding all pipe slip joints (headpipe to muffler, etc.). If no welding equipment is available at the time of installation, use the furnished clamps to secure the pipes until they can be welded.

**INSTALLATION PROCEDURE – PLEASE READ CAREFULLY:**

1. Remove the existing headpipe crossover and the single exhaust system. Save old gaskets and sleeves from the stock exhaust headpipes.
2. Install the new headpipes, using the old gaskets and sleeves. Tighten only enough to hold in place. Install the left and right rear section headpipe. On header duals, install the header extensions. **DO NOT TIGHTEN.**
3. Install mufflers on the headpipes or header extensions (see **Figure A**). Put clamps in place, but **do not tighten**. Rotate the headpipes and muffler to clear the driveshaft and frame. Over the front or rear of the muffler, you will find a crossmember or body mount that a hole can be drilled to accept a 5/16" bolt and rubber hanger.
4. On models with a 131.5" and 177.5" wheelbase, install the front tailpipe extension. On 117.5", cut approximately 14" off the front (see **Figure A**).
5. Install the tailpipes and center bump over the rear axle for maximum clearance.
6. As the tailpipe goes under the frame on its way out to the rear of the vehicle, find a hole in the area or drill a new hole to bolt the 90° metal bracket and rubber hanger. See **Figure A** for tailpipe location. Cut the end of the tailpipe for desired length.
7. Make sure that all parts of the system are clear of frame members, all hoses, suspension, and brake lines. Starting at the collectors, tighten all connections, making sure all parts are clear and will not leak or rattle.
8. Start the engine and check for leaks. Be sure that all brake lines, fuel lines, and electrical wires have sufficient clearance. Reroute as necessary.
9. When finished, give your car a test drive, checking carefully for any new noises. After several days of driving, retighten all the bolts.

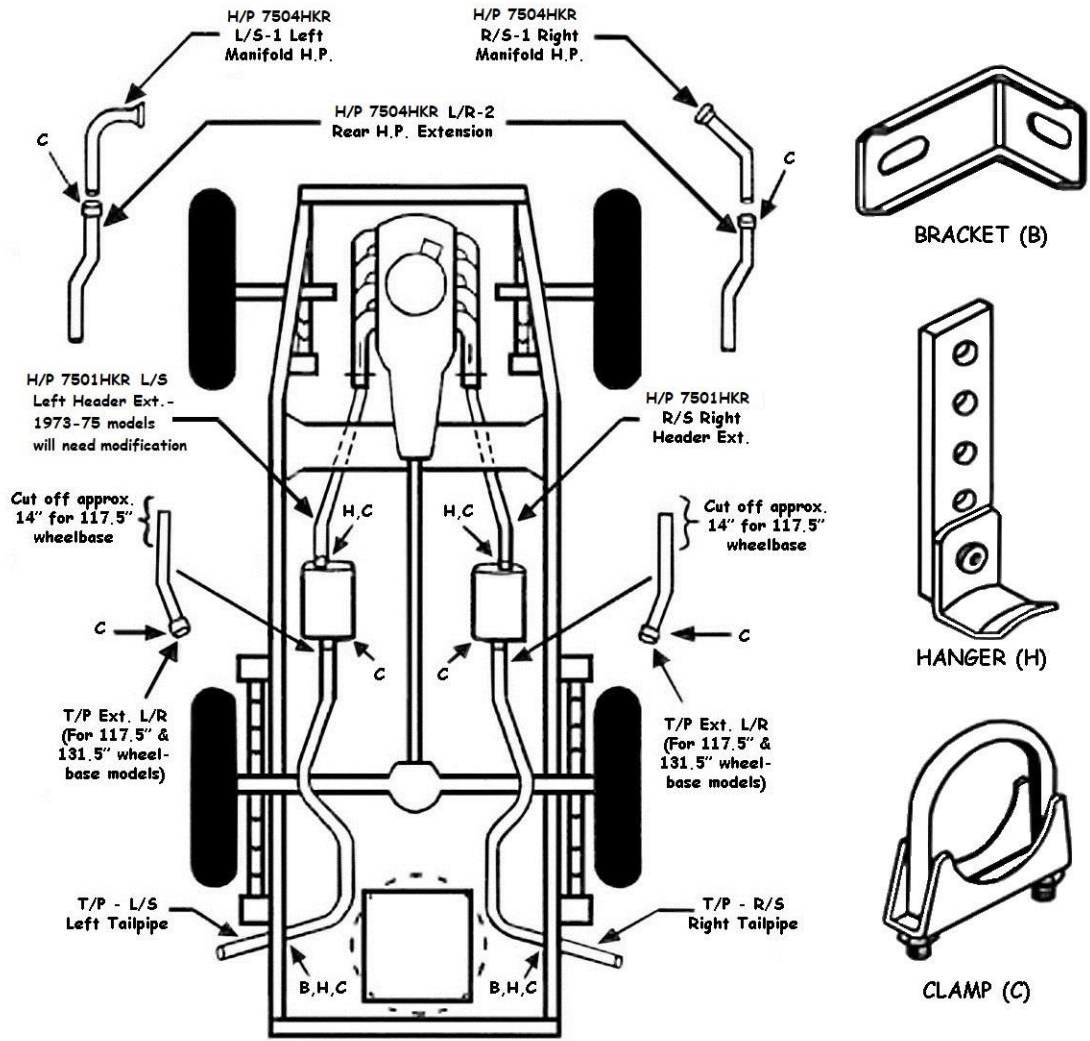

**Figure A**