

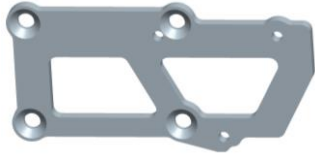

P/N 12611HKR, 12622HKR, 12623HKR, & 12624HKR SUPER COMPETITION ENGINE SWAP MOUNT KIT CHEVROLET/GMC ALL USING TYPICAL 3 BOLT ISOLATOR MOUNTS

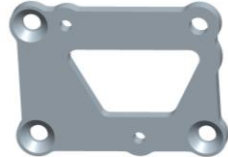

12611HKR (stock)



12622HKR (3" forward)

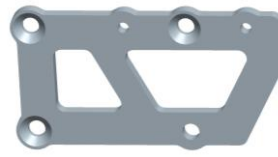

12623HKR (1 1/4" forward)

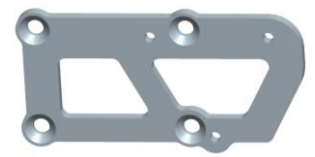

12624HKR (1/2" forward)

FROM STOCK TRANSMISSION LOCATION

Thank you for making HOOKER HEADERS your choice in engine swap mount kits. Extensive time and research has enabled HOOKER to offer the most options in engine swap mounts.

NOTE: 12611HKR engine swap mount kit is designed to locate a GEN III/IV (LS Based) engine so the transmission bellhousing is located in the same position as it was originally with a standard small block Chevy engine using a typical 3 bolt stock isolator mount.. The 12622HKR moves the engine 3" forward. The 12623HKR moves the engine 1 1/4" forward. The 12624HKR moves the engine 1/2" forward.

NOTE: Use only small block Chevy frame mounts. Big block mounts will not work.

NOTE: Worn rubber and solid isolator mounts should be replaced to ensure proper fit of the headers and other engine components that you may be installing.

NOTE: Isolator mounts are not included in this kit, due to the variations between vehicle applications.

TIPS FOR ENGINE SWAP

1. Mark all hoses, wires, and vacuum lines, according to function. Use masking tape and a pen to achieve this.
2. Whenever possible, utilize the existing wiring and lines.
3. Get a wiring diagram of your vehicle and one for the vehicle from which the new motor was removed. Make photocopies of both systems. Add your modifications to these copies, so you will have an accurate record.
4. Do not remove the smog systems for the sake of taking them off. Remember the smog laws go by the year and model of the vehicle in which the engine is installed. You may have difficulties from a legal standpoint, especially when you try to sell the vehicle.
5. Most newer engines are designed to run with the various smog system which came as original equipment. You may save yourself a great deal of time and trouble by attempting to keep the engine as close to stock as possible.
6. Save as much hardware that is removed from the vehicle as possible. You may need some items later on.
7. Do it right. Taking short cuts is not saving time, if you have to do it again. Make sure you pay close attention to critical areas like fuel systems and brake lines. These could be of life and death consequences, if ignored.
8. Do not overstress components that are designed for stock four or six cylinder torque by over-abuse with a motor of greater horsepower.

BEFORE STARTING

Your vehicle must be raised a minimum of 36 inches. A floor hoist is ideal. If no hoist is available, we strongly urge the use of axle stands as a safety measure. **CAUTION! YOUR CAR SHOULD NOT BE SUPPORTED ON A BUMPER JACK.**

INSTALLATION PROCEDURE – PLEASE READ CAREFULLY

1. Disconnect the battery, remove the hood, and mark all wires, hoses, cables, lines, and linkages. Remove the engine, transmission, front motor mounts, and transmission crossmember.
2. Bolt the plates to the engine using the flat head bolts provided. Torque to factory specifications. See the **Figures on page 2** for proper orientation of mount plates.

NOTE: On some applications, an M10 SHCS has been provided in the kit to bolt through the isolator into the engine block. As with all supplied SHCS, you must use the supplied lockwashers under the screw head.

3. Bolt the stock rubber or solid mount isolators to the mount plates using the supplied bolts and lockwashers (using longer bolts may interfere with support ribs on the engine). **DO NOT TIGHTEN THE BOLTS AT THIS TIME TO ALLOW SOME PLAY WHEN THE ENGINE IS BEING ALIGNED WITH THE FRAME STANDS OR CROSSMEMBER MOUNTING HOLES.**
4. Align the engine and transmission into the vehicle and adjust the isolators, as necessary. When satisfied with the fit, tighten the isolator mounts to the engine and frame stand or crossmember mounting holes.
5. Complete the installation as you would with any engine conversion.
6. Hook up all wires, hoses, cables, and linkages. Check to see that adequate clearance exists between all wires and brake lines. Check all bolts for tightness.

When finished, give your vehicle a test drive, checking carefully for any new noises. After several days of driving, retighten all the bolts.

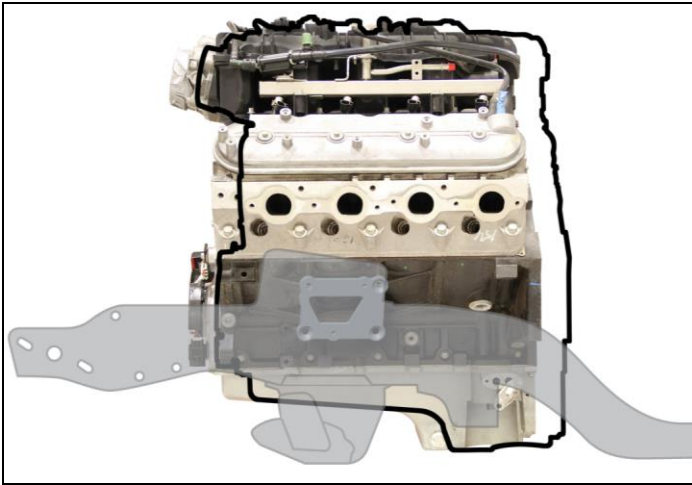

12622HKR

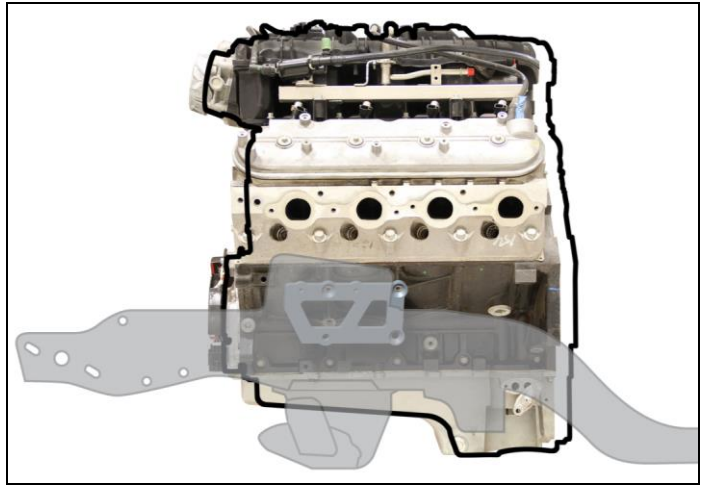

12623HKR

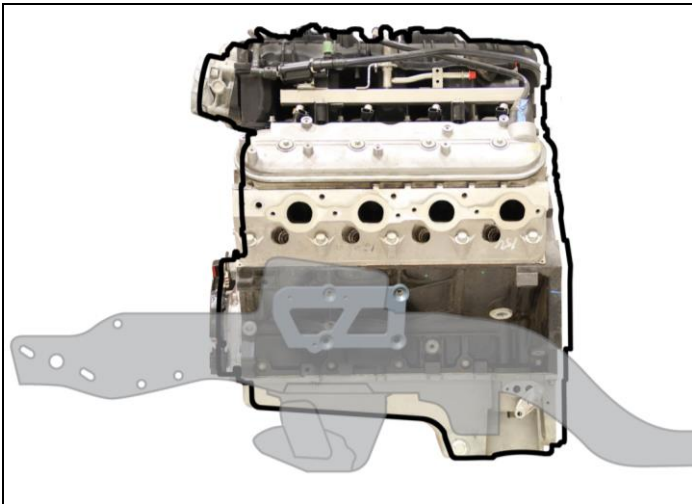

12624HKR

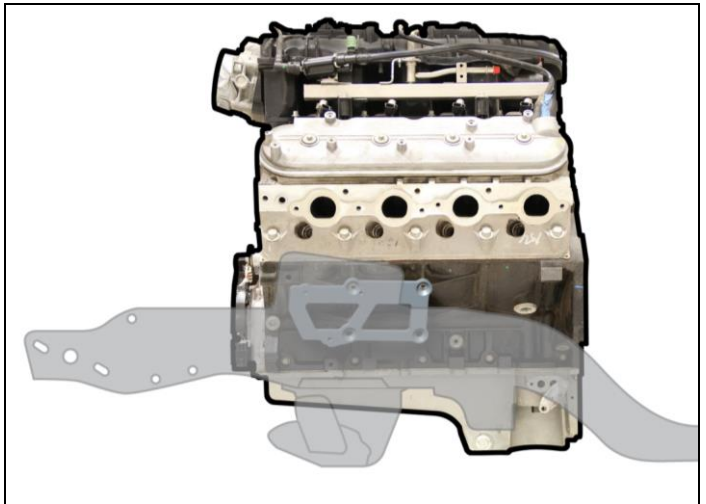

12611HKR