

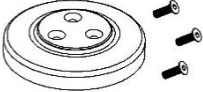



Accessory Covers

97-185, 97-186, 97-187, & 97-188

Parts List:

PICTURE	DESCRIPTION	Black	Polished
	SD7 Compressor Clutch Cover, (3) Flat Head Bolts 1/4"-20 X 3/4"	97-185	97-186
	Alternator Pulley Cover, O-ring retainer (Replacement size -217)	97-187 (works with P/N 197-302 and 197-303 alternators)	97-188 (Included with P/N 197-304 alternator)

Compressor Cover Assembly:

Works ONLY with SD7 style compressor.

Step one: Position cover on front of compressor. Rotate until cover aligns to the threaded holes on the compressor clutch.

Step two: Install the supplied bolts. Tighten in a sequential uniform manor. Torque to 6 Ft/lbs.

Step three: Start the engine. If the cover rotation is not true, loosen and retighten correcting the alignment.

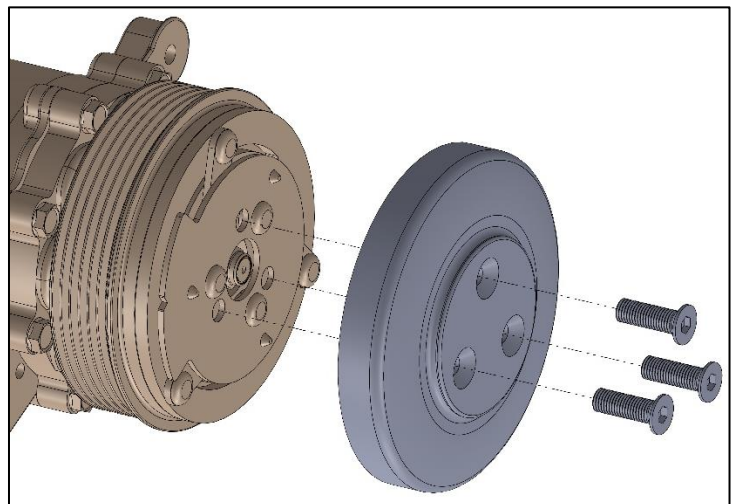

Alternator Cover Assembly:

Works ONLY with inside *grooved* Holley pulley.

Step one: Install supplied O-ring in the inside groove of the alternator pulley.

Step two: Firmly press the cover into the pulley. The cover should be worked-on until it fully touches the pulley face. After installation the cover may rebound slightly.

