

HP and Dominator Component Selection Guide

Use when building Dominator Systems or Custom HP Systems

Step 1 (required)

Choose your ECU & Main Power Harness

554-114 - Dominator ECU only*

554-113 - HP ECU only*

558-308 - Main Power harness (13' long)

Notes: ECUs include USB communications cable, mounting hardware and software CD.

***When purchasing an HP or Dominator ECU separately, a main power harness is required.**

Step 2 (required)

Choose Your Main Harness

GENERAL MOTORS

558-101 - TPI/SR Harness

558-102 - LS1 24x/1x Harness

558-103 - LS2 58x/4x Harness

UNIVERSAL

558-104 - Universal MPFI

558-105 - Unterminated Harness

FORD

558-108 - '99-04 2V & 4V Modular Main Harness

558-109 - Coyote Main Harness (*Locked VVT)

558-113 - Ford '99-04 2V & 4V Modular Main Harness, w/ Smart Coils

558-114 - Ford Coyote Non-VVT Main Harness, w/ Smart Coils

HEMI

558-106 - Gen III HEMI Main Harness, Early, w/ DBW Throttle Body

558-107 - Gen III HEMI Main Harness, Late, w/ DBW Throttle Body

558-115 - Gen III HEMI Main Harness, Early, w/ TPS and IAC

558-116 - Gen III HEMI Main Harness, Late, w/ TPS and IAC

Step 2 (notes)

Choose Your Main Harness

GM:

558-102 - (Step 4 NOT Required) Designed for 24x crank and 1x rear mount cam sensor. Connects to factory coil harnesses and all factory sensors. No Ignition Harness Required.

558-103 - (Step 4 NOT Required) Designed for 58x crank and 4x front mount cam sensor. Connects to factory coil harnesses and all factory sensors.

No Ignition Harness Required.

558-101 - (Step 4 Required) Designed for Holley Stealth Ram Systems and factory GM TPI engines (speed density). Not Intended for LT1/LT4 Optispark Ignition.

UNIVERSAL:

558-104 - (Step 4 Required) Fully terminated. Designed for single plane style EFI intake manifolds and Holley MPFI intakes.

558-105 - (Step 4 Required) 15' harness length. Fully terminated and populated at ECU connections only. User must terminate all sensor ends. Includes a variety of sensor connectors and pins but end user may have to supply sensor pins and connectors suited for their specific application. Ignition and Injector 10 pin connectors are supplied.

FORD:

558-108 - (Step 4 Required) Designed to be plug and play with '99-04 factory sensors. If retaining factory ignition coils, requires 558-314 (2v engine) or 558-315 (4v engine). See instruction sheet – 199R10724 for additional information

558-109 - (Step 4 Required) Designed to be plug and play with Coyote factory sensors (*Locked VVT) If retaining factory ignition coils, requires 558-317. See instruction sheet 199R10738 for additional information.

558-113 – (Step 4 Required) Designed to use most stock 2V or 4V Ford Modular Engines w/ Holley HP Smart Coils (556-112). Most stock sensors are retained. Requires 558-312. See instruction sheet 199R10861 for additional information.

558-114 – (Step 4 Required) Designed to be used with Ford Coyote Engines w/ Holley HP Smart Coils (556-112) (VVT Locked). Most stock sensors are retained. Requires 558-312. See Instructions 199R10862 for additional information.

HEMI:

558-106/107 - (Step 4 Required) Designed for Early (106) or Late (107) Hemi crank and cam sensor. Connects to all factory sensors.

558-115/116 – (Step 4 Required) Designed for Early (115) or Late (116) Hemi crank and cam sensor, utilizing a Holley Style 4bbl Throttle body TPS/IAC connectors. (I.E 112-587, or 112-588)

Step 3 (required)

Choose Your Injector Harness

GENERAL MOTORS

558-201 - LSx Inj Harness (EV6)

558-214 - LSx Multec 2 Inj Harness (early GM truck)

UNIVERSAL

558-200 - V8 injector harness (EV1)

558-202 - 4 Cyl Inj Harness (EV1)

558-203 - 6 Cyl Inj Harness (EV1)

558-204 - Universal Unterminated Inj Harness (EV1)

558-206 - Terminated 2x4 Holley TBI

558-207 - Unterminated 16 injector MPFI (EV1)

558-208 - Unterminated 24 injector MPFI (EV1)

FORD

558-209 - Ford V8 Injector Harness (EV1)

558-212 - Ford Evenly Spaced Inj. Harness (Uscar EV6, Evenly Spaced)

558-213 - Ford Evenly Spaced Inj. Harness (Jetronic EV1, Evenly Spaced)

HEMI

558-210 - HEMI inj. Harness (EV6)

558-211 - HEMI inj. Harness (EV1)

NOTES:

558-200/203 - Universal "Y" style harness using standard Jetronic (Bosch style) EV1 injector connectors

558-200/201 - "Y" style harness for Odd/Even Bank V8 engines using USCAR (EV6 style) of injector.

558-202 - Fully terminated 4 cylinder harness using standard Bosch style injector connectors.

558-204/207/208 - Terminated at injector connectors (Bosch style) EV1. Harness must be assembled and requires crimping Metripak 150 connectors. Includes all connectors, pins, terminals. Loom needed.

558-206 - Fully terminated harness when using two Avenger-style 4bbl Holley TBI units.



Jetronic Bosch-style EV1



USCAR EV6 Style



Multec 2 (early GM truck)

Step 3.1 (Optional)

Choose Your Injectors

- **522-191** - Single Inj 19PPH
- **522-198** - 8 pk Inj 19PPH 300HP
- **522-241** - Single Inj 24PPH
- **522-248** - 8 pk Inj 24PPH 385HP
- **522-301** - Single Inj 30PPH
- **522-308** - 8 pk Inj 30PPH 480HP
- **522-361** - Single Inj 36PPH
- **522-368** - 8 pk Inj 36PPH 575HP
- **522-421** - Single Inj 42PPH
- **522-428** - 8 pk Inj 42PPH 670HP
- **522-481** - Single Inj 48PPH
- **522-488** - 8 pk Inj 48PPH 765HP
- **522-661** - Single Inj 66PPH
- **522-668** - 8 pk Inj 66PPH 1050HP
- **522-831** - Single Inj 83PPH
- **522-838** - 8 pk Inj 83PPH 1325HP
- **522-121** - Single Inj 120PPH
- **522-128** - 8 pk Inj 120PPH 1900HP
- **522-161** - Single Inj 160 PPH
- **522-168** - 8pk inj 160 pph 2525HP

NOTES:

Holley Fuel Injectors have an EV1 Body Style, w/ a Jetronic (Bosch Style) Connector. Horsepower Ratings for Naturally Aspirated Gasoline Engine @ 43.5psi and 100% Injector Duty Cycle w/ a BSFC of .50 (Maximum Recommended Injector Duty Cycle = 80%) To Calculate Fuel Injector Size for custom or boosted gasoline applications, use the following Equations.

Typical BSFC numbers: N/A = .45-.50, Supercharged = .55-.60, Turbocharged = .60-.65

TO CALCULATE MAX HP FOR A GIVEN INJ. SIZE:

$\text{Inj. Size (lb./hr.)} \times \text{Duty Cycle} \div \text{BSFC} = \text{HP Per Inj.} \times \text{Quantity of Inj.} = \text{HP}$

Example: $(66 \times .8) \div .5 = 105.6 \times 8 = 844.8 \text{ HP}$

TO CALCULATE MAX HP BASED ON INJ. SIZE:

$\text{Inj. Size (lb./hr.)} = \text{HP} \div \text{number of cylinders} \times \text{BSFC} \div \text{Duty Cycle}$

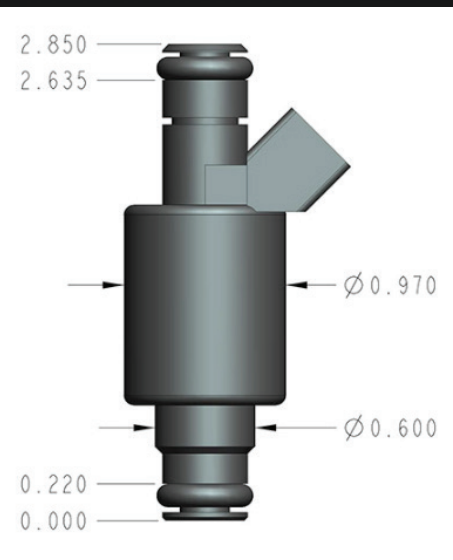

Step 4 (required)

Choose Your Ignition Harness

GENERAL MOTORS

558-304 - Small Cap Computer Controlled GM HEI Ign. Harness

UNIVERSAL

558-302 - Tach Input Adapter (CD Box Only, No Timing Control)

558-303 - Mag Pickup Ign Harness

558-306 - Universal Unterm Ign Harness

558-307 - Universal Coil On/Near Plug (COP) Ign. Harness

558-312 - HP Smart Coil Sub Harness

558-313 - FAST Ignition Adapter

558-410 - Crank/Cam Ign Harness (Hall Effect)

558-431 - Crank/Cam Ign. Harness (Ferrous Crank/Magnetic Cam)

FORD

558-305 - Ford V8 SFI TFI Ign. Harness

558-314 - 2V Ford Modular Coil Harness

558-315 - 4V Ford Modular Coil Harness

558-317 - Ford Coyote Coil Harness

HEMI

558-310 - HEMI Coil Harness, Early FCI

558-311 - HEMI Coil Harness, Late Tyco

Step 4 (notes)

Choose Your Ignition Harness

NOTES:

Select one that meets customer's needs if controlling timing.
No Ignition harness required if selecting a Holley EFI Distributor in Step 4.1

GM:

558-304 - Connects to small cap computer controlled GM HEI.

UNIVERSAL:

558-303 - Semi-Terminated. Used to connect to a magnetic pickup distributor or crank trigger. Customer must supply sensor connectors/pins.

558-306 - Semi-terminated. Includes all wiring to hook up to any crank and cam sensor. Shield/ground cable used. Customer must supply crank/cam pins and connectors for their specific sensor and may have to crimp metripak 150 pins.

558-307 - Allows the use of GM LSx coils or Holley HP smart coils on a non-LS engine, specifically the ECU to coil harness wiring. The customer has to supply either the factory GM coil harnesses for LS coils, or 558-312 sub-harness for Holley HP smart coils. This harness pins directly into the ECU.

558-313 - Designed to be used with a FAST Dual Sync Distributor.

558-410 - Fully terminated harness. Connects to Holley 60-2 crank sensor and GM Cam-Sync Distributor AC Delco PN 213-350.

558-431 - Designed to be used with a Hall Effect Crank Sensor (554-118) and a Magnetic Pickup Cam Sensor (554-125).

FORD:

558-305 - Connects to Ford 86-93 HO V8 SFI TFI distributors.

558-314 - Designed to be plug and play with 99-04 2v factory coils. (2) Coil Driver's required, Part number (1) 554-122 (Pair) or (2) 554-123 (Single).

558-315 - (2) Coil Driver's required, Part number 554-122 (Pair) or 554-123 (Single).

558-317 - (2) Coil Driver's required, Part number 554-122 (Pair) or 554-123 (Single). See Instruction sheet 199R10738 for additional information.

HEMI:

558-310 - Designed for early Hemi crank and cam sensor. Connects to and all factory Sensors. For Use with Stock Coils. 2x Coil Driver's required, Part number 554-122 (Pair) or 554-123 (Single).

558-311 - Designed for late Hemi crank and cam sensor. Connects to and all factory sensors. For use with Stock Coils. (2) Coil Driver's required, Part number 554-122 (Pair) or 554-123 (Single)

Step 4.1 (optional)

Choose Your Ignition

C-N-P COIL AND DRIVERS:

554-112 - Four Channel Coil Driver w/ Harness

554-122 - Eight Channel Coil Drivers*

554-123 - Four Channel Coil Drivers

556-112 - HP Smart Coil*

NOTES:

554-112 – Designed for driving “Dumb” coils on C-N-P swap applications. One module can drive 4 “Dumb” coils. Wiring harness with ECU Pins included.

554-122 - (2) Four Channel Coil Drivers – Designed to drive two wire “Dumb” Coils.

554-123 – (1) Four Channel Coil Driver. Designed to drive two wire “Dumb” Coils.

556-112 – Requires Sub Harness – 558-312. If running over 7,500RPM or 5.0Ms Dwell, refer to instruction sheet 199R10698 for additional information. Will support up to 5.5-6HP per Cubic Inch.

HOLLEY EFI DUAL SYNC

DISTRIBUTORS:

*If Selecting a Holley EFI Dual Sync Distributor, NO Ignition Harness is required.

GENERAL MOTORS

565-100 - SBC/BBC Billet Dual Sync Distributor

565-104 - BBC Tall Deck Billet Dual Sync Distributor

565-106 - Oldsmobile Billet Dual Sync Distributor

565-107 - Pontiac Billet Dual Sync Distributor

FORD

565-101 - SBF 351w Billet Dual Sync Distributor

565-102 - SBF 302 Billet Dual Sync Distributor

565-105 - Ford FE Billet Dual Sync Distributor

565-110 - Ford 351C, 400M, 429-460 Billet Dual Sync Distributor

CHRYSLER/MOPAR

565-103 - Chrysler RB Wedge Billet Dual Sync Distributor

565-108 - Chrysler SB Billet Dual Sync Distributor

565-109 - Chrysler 383-400 B-series Billet Dual Sync Distributor

NOTE: Holley EFI Dual Sync Distributors are designed to be Plug and Play with any of the Holley EFI Main Harnesses that are NOT Coyote/Hemi or LS Specific.

Step 4.1 (optional)

Choose Your Ignition

HOLLEY EFI CRANK/CAM SYNC:

GENERAL MOTORS CRANK SYNC

556-102 - SB Crank Sensor mounting kit

556-103 - BB Crank Sensor mounting kit

556-109 - SBC/BBC 8 1/2" 60-2 Crank trigger wheel

556-110 - 60-2 SBC Crank Trigger Kit (Sensor Included)

556-111 - 60-2 BBC Crank Trigger Kit (Sensor Included)

556-113 - BBC 8" 36-1 Crank Trigger Kit (Sensor Included)

556-116 - SBC 8" 36-1 Crank Trigger Kit

GENERAL MOTORS CAM SYNC (SENSOR INCLUDED)

556-114 - BBC Standard Cam Height – Cam Sync Kit

556-119 - SBC Standard Cam Height – Cam Sync Kit

556-120 - BBC +.400 Raised Cam Height – Cam Sync Kit

556-121 - BBC +.600 – 1." Raised Cam Height – Cam Sync Kit

UNIVERSAL CRANK SYNC

556-106 - 5" 60-2 Crank trigger wheel

556-107 - 6" 60-2 Crank trigger wheel

556-108 - 7-3/4" 60-2 Crank trigger wheel

556-125 - 8" 36-1 Universal Crank Trigger Wheel

556-126 - 7.25" 36-1 Universal Crank Trigger Wheel

UNIVERSAL CAM SYNC

556-123 - Universal Cam Sync Kit (Sensor Included)

FORD

556-115 - SBF 7.25" 36-1 Crank Trigger Kit (Sensor Included)

SENSORS

FLYING MAGNET TARGET

554-118 - Hall Effect – 3/4" – 16, MSD “Flying Mag.” Replacement

554-125 - Hall Effect Cam Sync – M12x1

554-127 - Hall Effect Cam Sync – M12x1 – W/ Flying Magnet Target

554-126 - Flying Magnet Target – 1/4" -20 x 3/8" *

FERROUS TARGET

554-117 - Hall Effect – 60-2 Replacement Sensor

554-124 - Hall Effect – M12x1 – Ferrous Target, 36-1 Replacement

Step 4.1 (notes)

Choose Your Ignition

NOTES:

Choose all that apply to your customer.

554-117 – Hall Effect Sensor designed for a ferrous metal (Magnetic Steel) target, such as a Holley 60-2 or 36-1 Crank Trigger Wheel. Could also be used as a Cam Trigger Sensor. (Push-in Style)

554-118 - Hall Effect Crank sensor designed as a drop-in sensor replacement for flying magnet crank trigger setups using a 3/4" – 16 threaded magnetic sensor. This sensor is a Hall Effect sensor, meaning it outputs a square wave signal, which is ideal for use with most Electronic Fuel Injection Systems. This sensor is to only be used with a trigger wheel with “flying magnets” such as MSD Crank Trigger Wheels. It does not detect a ferrous steel target.

554-124 - Hall Effect Sensor designed for a ferrous metal (Magnetic Steel) target, such as a Holley 60-2 or 36-1 Crank Trigger Wheel. Could also be used as a Cam Trigger Sensor. (M12x1 Thread Pitch)

554-126 – Flying Magnet Target Only. Requires compatible sensor such as part number 554-125.

554-125/127 - Hall Effect sensor designed for flying magnet Cam Sync setups using a M12x1 threaded magnetic sensor. This sensor is a Hall Effect sensor, meaning it outputs a square wave signal, which is ideal for use with most Electronic Fuel Injection Systems. This sensor comes with a “Flying Mag” Target (1/4" -20 x 3/8" Thread) It does not detect a ferrous steel target.

556-113/116 – Designed for use on early model SBC/BBC applications with a standard ATI or Fluidamper “style” balancer up to 7 1/4" Diameter.

556-115 - Designed for use on SBF applications with a standard ATI or Fluidamper “style” balancer up to 7 1/4" Diameter.

Step 5 (optional)

DOMINATOR ECU ONLY

Choose Your Transmission Control

GENERAL MOTORS

558-405 - 4L60/80E Harness

FORD

558-470 - 4R70W/AODE Harness

Notes:

558-405 - Fully terminated harness for GM 4L60E/65E/80E transmissions. When utilized with a 4L60E Verify it has a 12pin connector ('95 – Up). This harness is not intended to work with '94 and earlier 4L60 Transmissions.

558-470 – Ford 4R70W/AODE Transmission Harness ('98 – Up)

Step 6 (optional)

DOMINATOR ECU ONLY

Choose Your Throttle Body/Drive-By-Wire Control

GENERAL MOTORS

558-406 - GM DBW Harness (6 Pin TB Connector)

558-411 - Dual GM DBW Harness (6 Pin TB Connector)

558-429 - GM DBW Harness – Early Truck (8 Pin TB Connector)

FORD

558-422 - Ford Coyote DBW Harness

HEMI

558-417 - Hemi DBW - Early Pedal

558-418 - Hemi DBW - Late Pedal

558-437 - Hemi DBW Harness - 2013+

558-450 - Dual DBW Hemi - Late Pedal

NOTES:

The following part numbers should be available through your local dealership.

GM applications only work with the following throttle bodies and DBW pedal assembly

APPROVED GM THROTTLE BODIES:

GM Part # - **12570800**

GM Part # - **12570790**

GM Part # - **12580760**

GM Part # - **12580195**

GM Part # - **12605109**

GM Part # - **12629992**

GM THROTTLE PEDAL ASSEMBLIES:

GM Part # - **10379038**

Lokar Part # - **BDBW-GM02**

APPROVED FORD THROTTLE BODIES:

Ford Part # - **7R3Z 9E926-AA** (GT500)

Ford Part # - **BR3E-9F911-AB** (Coyote)

Ford Part # - **BR3Z-9F836-D** (Coyote)

FORD THROTTLE PEDAL ASSEMBLIES:

Ford Part # - **BR3Z-9F836-C** (Coyote)

Ford Part # - **BR3Z-9F836-D** (Coyote)

APPROVED CHRYSLER THROTTLE BODY (DBW):

Chrysler Part # - **04591847**

CHRYSLER PEDAL ASSEMBLIES:

Chrysler Part # - **0486 1708** (558-417 Specific)

Chrysler Part # - **0486 1714** (558-418 Specific)

Step 7 (optional)

Choose your Auxiliary Harness

534-199 - Wideband Oxygen Sensor Extension Cable, 4'

558-400 - J1A/B I/O Cnctr. Dom & HP

558-401 - J2A Cnctr. & Harness, #2 wide band, **Dom only**

558-402 - J2B Cnctr. & Harness, **Dom only**

558-403 - J3 Cnctr. & Harness, **Dom only**

558-404 - J4 Cnctr. & Harness, **Dom only**

558-408 - J2-J4 Cnctr. Kit, **Dom only**

NOTES:

558-400 - Connects into Main Harness Input/Output Connector (8 pin metripak). Loose lead wires.

558-401 - Includes J2A ECU connector with fully terminated #2 wide band oxygen sensor cabling. Comes with loose lead wires for all other input connections (qty 23). ECU pins are pre-crimped.

558-402 - Includes J2B ECU connector. Includes all output connection wires (qty 16). ECU pins are pre-crimped.

558-403 - Includes J3 ECU connector. Includes all input and output connection wires (qty 17). ECU pins are pre-crimped. (Not available in DBW Throttle Body Applications)

558-404 - Includes J4 ECU connector. Includes all input and output connection wires (qty 26). ECU pins are pre-crimped. (Not available in Trans Control Applications)

558-408 - Contains J2-J4 connectors and pins, no wiring. Requires ECU Pin Crimping Tool – **567-100**.

Step 7.1 (optional)

Choose your Auxiliary Accessories

554-111 - 40 Amp Solid State Relay

554-128 - Transbrake Input Protection Module

567-100 - ECU Pin Crimp Tool

558-407 - Multi Map Selector

558-409 - Sealed 7' USB Cable

558-438 - Sealed 15' USB Cable

NOTES:

554-111 – This solid state relay has a maximum continuous current draw of 40 Amps.

558-407 – Four position key switch that allows the user to select from 4 stored calibrations without the need of a laptop. DOMINATOR ECU ONLY.

554-128 – This device that allows for an ECU input to be safely connected directly to the +12V side of the transbrake solenoid.

This device protects the ECU input from damaging flyback voltage which occurs when the transbrake is released. Not using this device will cause damage to the ECU over time.

Step 8 (required)

Choose your Wideband Sensor

554-100 - NTK Wideband Sensor

554-101 - Bosch Wideband Sensor

Notes:

A Holley EFI Wideband is required for Closed Loop.

Oxygen sensor recommendation:

The NTK sensor is recommended when using leaded or methanol fuels, high exhaust and forced induction applications or for highest precision feedback.

Step 8.1 (optional)

Choose additional sensors

PRESSURE

554-102 - 100 PSI Sensor

554-103 - 200 PSI Sensor

554-104 - 1600 PSI Sensor

554-137 - 3000 PSI Sensor

554-138 - 100 PSI/-40°C to 105°C Combo Sensor

MAP

538-24 - 1 bar MAP Sensor

554-133 - 1 bar MAP Sensor - 1/8 NPT

538-13 - 2 bar MAP Sensor

554-107 - 3 bar MAP Sensor

554-134 - 3.5 bar MAP Sensor - 1/8 NPT

554-108 - 5 bar MAP Sensor - 1/8 NPT

554-135 - 7 bar MAP Sensor - 1/8 NPT

TEMPERATURE

534-10 - Coolant Temp Sensor - GM style

534-20 - Air Temp Sensor - GM style

TPS

543-111 - GM style TPS Sensor

543-112 - Race TPS Sensor

IAC

543-105 - Chrysler Style IAC Motor

543-2 - GM Screw-In Style IAC Motor

ADAPTERS

558-416 - LS Main Harness to LS3-Style MAP Sensor

534-205 - MPFI Sensor Connector Kit

Step 8.1 NOTES:

Choose additional sensors

NOTES:

Choose all that apply to your customer
534-205 – Includes pins, seals, and connectors for: MAP/IAC/TPS/CTS/IAT – Gm 3 Round TPS, Chrysler 4 Flat IAC, 3 pin Weather-Pack MAP.

534-213 - Includes pins, seals, and connectors for: MAP/IAC/TPS/CTS/IAT – GM 4 Square IAC, GM 3 Flat TPS, 3 pin Weather-Pack MAP.

554-102/103/104/107/108/112 – Come with short pigtail connector for sensor.

554-102/103/104/108/133/134/137 – These stainless steel sensors have a 1/8" -27NPT thread pitch. They are also not designed to be rigidly mounted.

543-105 – Used on 112-577,112-578,112-587,112-588 and 112-602 Holley 4bbl MPFI Throttle Bodies.

543-111 – Used on 112-577,112-578,112-587, and 112-588 Holley 4bbl MPFI Throttle Bodies.

543-112 – Used on the 112-602 Holley 4bbl MPFI Throttle Body.

558-416 – LS Main Harnesses have a MAP sensor connector designed for use with an LS1/2 style MAP sensor. This adapter is required when utilizing a LS3 style MAP Sensor.

Step 9 (optional)

Choose your Power adder Accessories

BOOST CONTROL

557-200 - 3 Port Solenoid Valve

NITROUS

554-111 - Nitrous Solenoid Driver

WATER METH

554-115 - Peak and Hold Module, Water/Meth - Can drive up to (2) 1000CC nozzles

557-100 - Pump - Can supply up to (3) 1000CC nozzles

557-101 - Installation Kit

557-106 - Solenoid/Nozzle 1000CC to 800HP

557-107 - Water Injection Filter

NOTES:

554-111 - The nitrous solenoid driver is REQUIRED when progressively controlling nitrous oxide solenoids. It can be used for non-progressive nitrous to replace a standard relay. Requires a PWM - (ground) output. One per stage, 40A max each. Not rated for continuous duty PWM. **554-115** - Required to drive a water/methanol solenoid if there is not an extra injector driver available. Notes: For a complete water meth. kit, a pump, installation kit, filter and solenoid nozzle of the appropriate size is required. A peak and hold module may be required when using an HP ECU.

Step 10 (optional)

Choose your Display

553-106 - 7" LCD Touch Screen Digital Dash

553-107 - LED Light Bar (Programmable Shift Light)

553-108 - 3.5" LCD Touch Screen Hand-Held

554-130 - Analog Gauge Module

554-140 - GPS USB Module

558-412 - CAN2 Connector/Cable Kit (for Racepak & other external CAN drives)

558-430 - CAN Adapter/Power Harness

553-107 – May be used with 553-106 Only!

554-140 – May be used with 553-106 Only!

558-412 – Dominator ECU Only.

558-430 – Used to adapt old style 2pin CAN Connector to new style 4pin CAN Device.

Step 11 (optional)

Choose your Fuel System

DROP-IN SOLUTIONS

12-130 - 255LPH Drop-In Retrofit EFI Module Return Style w/Hydramat

12-131 - 255LPH Drop-In Retrofit EFI Module Returnless Style w/Hydramat

12-132 - 450LPH Drop-In Retrofit EFI Module Return Style w/Hydramat

12-133 - 450LPH Drop-In Retrofit EFI Module Returnless Style w/Hydramat

EXTERNAL SOLUTIONS

600HP NATURALLY ASPIRATED @43PSI

– GASOLINE

380HP FORCED INDUCTION @60PSI

– GASOLINE

12-600 - HP™ Billet In-Line pump

12-846 - HP™ Billet Fuel Pressure regulator, EFI By-Pass - 40-70 psi

162-554 - 175 GPH HP™ Billet Fuel Filter -8AN – 10 Micron

162-564 - 175 GPH HP™ Billet Fuel Filter -8AN – 100 Micron

Step 11 (optional)

Choose your Fuel System

EXTERNAL SOLUTIONS

700HP NATURALLY ASPIRATED @45PSI – GASOLINE

550HP FORCED INDUCTION @60PSI – GASOLINE

12-920 - In-Line Universal Electric Fuel Pump

12-846 - HPT™ Billet Fuel Pressure regulator, EFI By-Pass - 40-70 psi

162-551 - 175 GPH HPT™ Billet Fuel Filter 3/8" – 10 Micron

162-552 - 175 GPH HPT™ Billet Fuel Filter 3/8" – 100 Micron

EXTERNAL SOLUTIONS

800HP NATURALLY ASPIRATED @43PSI – GASOLINE

530HP FORCED INDUCTION @60PSI – GASOLINE

12-800 - HPT™ Billet In-Line pump

12-846 - HPT™ Billet Fuel Pressure regulator, EFI By-Pass - 40-70 psi

162-554 - 175 GPH HPT™ Billet Fuel Filter -8AN – 10 Micron

162-564 - 175 GPH HPT™ Billet Fuel Filter -8AN – 100 Micron

EXTERNAL SOLUTIONS

900HP NATURALLY ASPIRATED @43PSI – GASOLINE

600HP FORCED INDUCTION @60PSI – GASOLINE

12-890 - HPT™ Billet In-Line pump

12-846 - HPT™ Billet Fuel Pressure regulator, EFI By-Pass - 40-70 psi

162-554 - 175 GPH HPT™ Billet Fuel Filter -8AN – 10 Micron

162-564 - 175 GPH HPT™ Billet Fuel Filter -8AN – 100 Micron

EXTERNAL SOLUTIONS

1200HP NATURALLY ASPIRATED @43PSI – GASOLINE

800HP FORCED INDUCTION @60PSI – GASOLINE

12-1200 - Dominator™ Billet In-Line pump

12-1200-2 - Dominator™ Billet In-Line pump (Dual Inlet)

12-848 - Dominator™ Billet Fuel Pressure Regulator, EFI By-Pass -40-70 psi

162-570 - 260 GPH Dominator™ Billet Fuel Filter - 12AN – 10 Micron

162-572 - 260 GPH Dominator™ Billet Fuel Filter - 12AN – 100 Micron

Step 11 (optional)

Choose your Fuel System

EXTERNAL SOLUTIONS

1600HP NATURALLY ASPIRATED @43PSI – GASOLINE

1050HP FORCED INDUCTION @60PSI – GASOLINE

12-1600 - Dominator™ Billet In-Line pump

12-1600-2 - Dominator™ Billet In-Line pump (Dual Inlet)

12-848 - Dominator™ Billet Fuel Pressure Regulator, EFI By-Pass -40-70 psi

162-570 - 260 GPH Dominator™ Billet Fuel Filter - 12AN – 10 Micron

162-572 - 260 GPH Dominator™ Billet Fuel Filter - 12AN – 100 Micron

EXTERNAL SOLUTIONS

1800HP NATURALLY ASPIRATED @43PSI – GASOLINE

1200HP FORCED INDUCTION @60PSI – GASOLINE

12-1800 - Dominator™ Billet In-Line pump

12-1800-2 - Dominator™ Billet In-Line pump (Dual Inlet)

12-848 - Dominator™ Billet Fuel Pressure Regulator, EFI By-Pass -40-70 psi

162-570 - 260 GPH Dominator™ Billet Fuel Filter - 12AN – 10 Micron

162-572 - 260 GPH Dominator™ Billet Fuel Filter - 12AN – 100 Micron

EXTERNAL SOLUTIONS

2150HP NATURALLY ASPIRATED @43PSI – GASOLINE

1500HP FORCED INDUCTION @60PSI – GASOLINE

12-1500 - VR1 Billet Brushless Fuel Pump w/ Controller

12-851 - VR Series 2 Port Fuel Pressure Regulator, EFI By-Pass – 40-100PSI

12-864 - VR Series 4 Port Fuel Pressure Regulator, EFI By-Pass – 40-100PSI

162-577 - 460 GPH Dominator™ Billet Fuel Filter - 12AN – 10 Micron

162-575 - 460 GPH Dominator™ Billet Fuel Filter - 12AN – 100 Micron

Step 11 (optional)

Choose your Fuel System

EXTERNAL SOLUTIONS

4400HP NATURALLY ASPIRATED @43PSI – GASOLINE

3200HP FORCED INDUCTION @60PSI – GASOLINE

12-3000 - VR2 Billet Brushless Fuel Pump w/ Controller

12-3000-2 - VR2 Billet Brushless Fuel Pump w/ Controller (Dual Inlet)

12-851 - VR Series 2 Port Fuel Pressure Regulator, EFI By-Pass – 40-100PSI

12-864 - VR Series 4 Port Fuel Pressure Regulator, EFI By-Pass – 40-100PSI

162-577 - 460 GPH Dominator™ Billet Fuel Filter - 12AN – 10 Micron

162-575 - 460 GPH Dominator™ Billet Fuel Filter - 12AN – 100 Micron