



Holley EFI Water/Methanol Injection System Installation P/N 557-101

SYSTEM INFORMATION:

This system is designed for use with Holley HP and Dominator EFI systems. It is not a stand-alone system. The components are designed for 100% water and up to a 50/50 percent mixture of water and methanol. Windshield washer fluid is commonly used. Do NOT use more than 50% methanol in the mixture, or damage to components may result.

NOTE: If you use other hardware in the installation of this system, it must be compatible with the fluid you use. Brass, aluminum, steel, natural rubber, and silicone are not suitable for use with a water/methanol mix and should not be used.

NOTE: The solenoids must be driven by an ECU injector driver output. If an extra injector driver channel is not available, a PWM output can be used to trigger Holley PN 554-115. This is a two channel injector driver device that can control two water meth solenoids using two high (+) or low (-) side PWM outputs.

PARTS REQUIRED:

This kit is an installation kit only. A pump and solenoid(s) are required as well. Note that you must use Holley solenoids for proper operation in conjunction with HP and Dominator EFI systems. The system is set up to allow up to two solenoids to be controlled. These parts are offered by Holley in the following PN's:

557-100 – Pump. This is not an “off the shelf agricultural pump”. It is designed for water/methanol injection.

557-103 – Solenoid/Nozzle Assembly (includes bung) 600cc/min – 400 HP engines

557-105 - Solenoid/Nozzle Assembly (includes bung) 900cc/min – 600 HP engines

557-106 - Solenoid/Nozzle Assembly (includes bung) 1000cc/min – 800 HP engines

557-107 – Replacement Filter

KIT CONTENTS:



Reservoir



Low Level Float



1/4" ID, 1/2" OD Tubing – 6 ft



Polyurethane 1/4" OD tubing – 16 ft



Filter



Nylon 3/8" NPT – 1/4" ID tube fitting



Relay



Stainless 3/8" NPT -1/4" OD tube fitting



Relay Wiring/Fuse



Warning LED

HARDWARE INSTALLATION:

Low Fluid Sensor – If using the option Low Fluid sensor, drill a 5/16" diameter hole in the BOTTOM of water reservoir. Make sure the location is flat and smooth or leaks can result. Remove any burrs from the drilled hole. Once drilled, remove the nut and insert the wires and sensor through the fill hole in the reservoir. Insert them through the drilled hole. Install the nut and tighten snugly. Do NOT over-tighten or you will damage the sensor.

Reservoir Installation – The reservoir needs to be installed in a manner that it gravity feeds the pump. The outlet of the reservoir should be higher than the inlet of the pump. Securely fasten the reservoir as is convenient.

Pump Installation – The pump is heavy and should be securely fastened. Make sure the pump inlet is below the outlet of the tank.

Filter and Soft Plumbing – Use the ½" OD rubber tubing to plumb from the tank to the pump. Install the filter somewhere in-between. Clamps are not required on this connection. If you desire to use a clamp, a small zip tie can be used. Use of a metal band clamp, if over-tightened can damage components.

Solenoids – Bungs are included with the solenoids Holley offers. The solenoids include fittings to connect the supply lines as well. Weld the fittings into the desired position in the air intake tract. The solenoid nozzle assembly can be installed in any orientation. The nozzle and fittings have been pre-installed into the solenoid using a special thread sealing compound to prevent leaks, and may be damaged if forced apart. Do not remove the fitting or nozzle or they will be damaged.

Plumbing from Pump to Solenoid(s) – Use the included Polyurethane tubing to plumb from the pump to the solenoids. When you cut the tubing, make sure the cut is square, and clean. Insert the tube into the fitting and ferrule until it bottoms out. Tighten nut hand-tight. Then tighten with a wrench 1 and ¼ turns more.

If you disassemble the fitting, when you re-tighten it (called a "remake"), it is best to turn the nut back to the exact same position that it was originally tightened to (mark it with a marker when you disassemble it). After this, snug slightly with a wrench. If you didn't mark the original position, tighten by hand, turn ¼ turn with a wrench, then snug slightly.

If you over-tighten you will reduce the amount of acceptable remakes.

2 solenoids – If you are running two solenoids, you need a "T" fitting to go to them. McMaster-Carr PN 5182K434 or 8239K223 can be utilized.

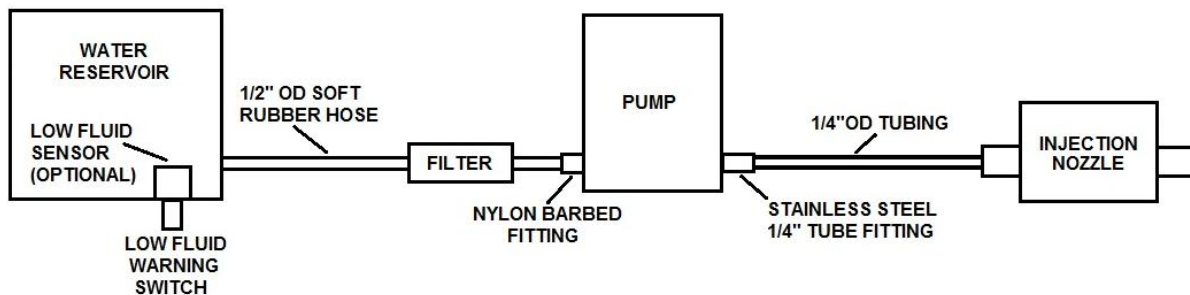

Figure 1 – Hardware Installation

WIRING:

Figure 2 shows how to wire the system.

NOTE: Make sure you configure the Water/Meth inputs and outputs as indicated below in the software!! If you don't the system will work improperly, and damage can result.

Pump Wiring – A high current relay is supplied. This relay **MUST** be connected as shown or it will be damage. Connect the orange wire to battery power. Do NOT connect it to the pump! Connect the red wire to the red wire on the pump. Connect the black wire on the pump to a solid chassis ground.

The relay has a black/yellow striped wire. This wire should be connected to the “W/M Pump Activate” output of the ECU.

Make sure you configure this as a GROUND output in the software. This relay requires a ground activation trigger.

Nozzle Wiring – Connect the red wire of the water meth nozzle to the injector driver output of the ECU (or the 554-115 output). The injector driver outputs are a ground trigger. Connect the blue wire to a fused, +12v switched power that can safely supply at least 2 amps.

The software needs to be configured properly. “W/M Solenoid #1” and “W/M Solenoid #2” should be set to output type “Injector Driver” if you connect directly to an ECU injector driver output. If you are using the 554-115 module, select “PWM+” or “PWM-” as directly by the 554-115 instructions.

Low Fluid Sensor Wiring – One side of the Low Fluid Sensor should be connected to a good chassis ground. The other side should be connected to the pin used for the “W/M Low Fluid In” Input.

Make sure this is configured as a GROUND input in the software.

Warning LED Wiring – A low fluid warning LED is included. It can be set up to activate if the low fluid sensor is triggered. Connect one side of the LED to power or ground. Connect the other side of the LED to the ECU output configured as “W/M Low Fluid”.

Configure the ECU “W/M Low Fluid” output to the opposite of what the LED is wired to. If you connect the LED to +12v power, configure the ECU output as GROUND. If you connect the LED to ground, configure the ECU output as +12V.

Water Meth Manual Enable Input – This is not show on Figure 2 below. If you want to have a switch what allows for the W/M to be disabled, select the “Enable Manual Activation” in the software. Configure this input as GROUND or +12V. Run a ground or 12V through a toggle switch accordingly, and run it into this pin configured for this input. When the switch is off, W/M injection will not occur. When the switch is turned on, injection will occur.

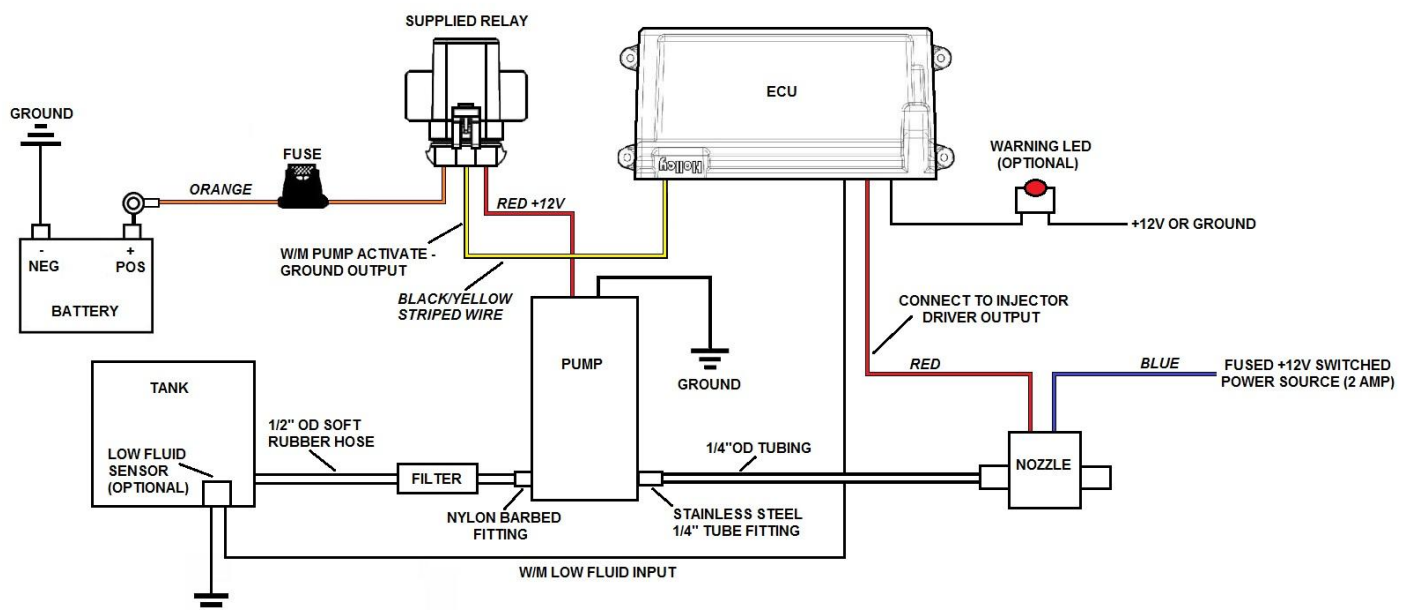

Figure 2 – Electrical Wiring