



HOLLEY® DUAL TANK INSTALLATION KITS 534-37 & 534-38

(534-37 – for all Holley® 2bbl TBI EFI systems up to 400 HP)
(534-38 – for all Holley® MPI / TBI / Terminator EFI systems up to 600 HP)

This kit is designed to allow the use **for all Holley® MPI / TBI / Terminator EFI systems** on vehicles equipped with dual fuel tanks. The fuel injection systems require a fuel return line. In dual tank applications, the fuel must be returned to the tank from which it was drawn.

In addition to the items included in this kit, you will also need fuel hose, EFI pressure rated hose clamps, 18 gauge wire, a 10 AMP in-line fuse, assorted terminals, and assembly lube (Earl's P/N 184004ERL or equivalent mineral oil that is compatible with your hose). The selection valve switches tanks by reversing the polarity of the "D" and "E" terminals. Many trucks equipped with dual tanks already have this type of selection valve along with the associated hardware.

INSTALLATION INSTRUCTIONS

1. Mount the selection valve in a protected location close to the existing fuel lines and near the fuel tanks. Position the valve so the side with the four ports points toward the fuel tanks. Mount the fuel pumps along the fuel supply lines and next to each fuel tank.

NOTE: The best location for mounting any electric fuel pump is near the fuel tank and in a position lower than fuel level that will allow the fuel to be gravity fed to the pump. As such, they need to be located at or below the bottom of the tank. Mounting the fuel pumps above fuel level will result in pump failure. The pump should be mounted on a solid member, such as the chassis. Avoid exposure of the pump and fuel lines to moving parts and to any hot areas, such as the exhaust manifold. The pump should not be mounted in an enclosed area.

2. Make sure the pump inlets point towards the fuel tanks. Connect the fuel lines as shown in **Figure 1**. The supplied 100 Micron (or equivalent) pre-filter needs to be installed between the fuel tank and the fuel pump.

WARNING! THE PUMP MUST BE PLACED WHERE INTERFERENCE BETWEEN THE VEHICLE'S BODY AND ITS CHASSIS MOVEMENT IS AVOIDED. THE PUMP AND ITS CONNECTING HOSES MUST NOT BE SUBJECTED TO LOW GROUND CLEARANCE, WHERE ANY FLYING ROCKS OR ROAD DEBRIS CAN CAUSE DAMAGE. FAILURE TO AVOID THESE HAZARDS WILL LEAD TO PUMP DAMAGE, WHICH COULD RESULT IN FIRE AND/OR PROPERTY DAMAGE, SERIOUS INJURY, AND/OR DEATH.

NOTE: When installing all fuel lines, use assembly lube to ease installation, as these fit tightly. The hose barbs are designed for EFI rated fuel hose with 3/8" and 5/16" inside diameter. Forcing improper sized fuel hose can damage valve and/or hose, resulting in PROPERTY DAMAGE, SERIOUS INJURY, AND/OR DEATH. Damage caused by improper installation is not covered under warranty.

CAUTION: The supply and return hoses from the same tank must be connected next to each other on the selection valve. All hoses should be secured with EFI Pressure rated hose clamps. It is highly recommended that you avoid sharp bends in the fuel lines.

WARNING! DO NOT USE PTFE TAPE ON PUMP FITTINGS. THIS TAPE CAN BREAK DOWN WHEN IT COMES IN CONTACT WITH FUEL. THE PTFE TAPE MAY PLUG THE FUEL PUMP OR VALVE, CAUSING DAMAGE TO THE PUMP OR VALVE AND THE FUEL SYSTEM.

NOTE: Avoid unnecessary restrictions, such as sharp bends and undersized fuel fittings and hoses. Avoid routing fuel lines in areas that would cause chafing. All fuel line connections must be leak proof.

WARNING! IF SPLICING INTO EXISTING FUEL LINES, USE EXTREME CARE TO AVOID CONTAMINATING THE LINE WITH RUBBER OR METAL SHAVINGS, AS THIS WILL DAMAGE THE PUMP OR VALVE. IF THE FUEL LINE HAS BEEN CUT, IT IS ESSENTIAL THAT IT BE CLEANED TO ENSURE THAT NO METAL OR RUBBER PARTICLES ENTER THE FUEL SYSTEM. THIS IS PERFORMED BY BLOWING THE LINE CLEAN WITH COMPRESSED AIR. HOLLEY DOES NOT RECOMMEND THE PROCEDURE WHERE THE COIL WIRE IS DISCONNECTED, THE ENGINE IS CRANKED, AND THE FUEL IS COLLECTED IN A CONTAINER. SPARKING CAN OCCUR DURING THIS PROCEDURE, WHICH MAY RESULT IN A FIRE AND/OR EXPLOSION.

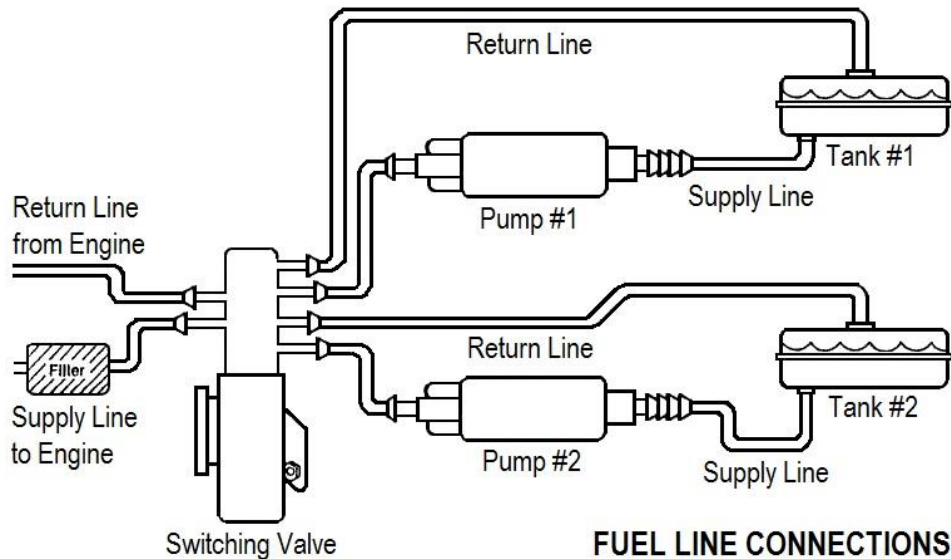

Figure 1

1. Mount the two position (both on) type of toggle switch along with the relay under the dash if the vehicle is not already equipped with these. Connect the electrical wiring as shown in **Figure 2**.

NOTE: All wiring should be 18 gauge or heavier.

2. Cross-wire the toggle switch as illustrated with one pair of terminals wired to ground and the other pair to a 12V source through the relay and a 20 AMP fuse. The terminals on the plug-in connector are labeled A – F (F E D C B A) and should be wired to the following items. See **Figure 2**.

- | | |
|--------------------------------|---------------------------------|
| A – Fuel Sending Unit, Tank #1 | D – Fuel Pump #2 (+) and Switch |
| B – Fuel Gauge at Dash | E – Fuel Pump #1 (+) and Switch |
| C – Fuel Sending Unit, Tank #2 | F – Not Used |

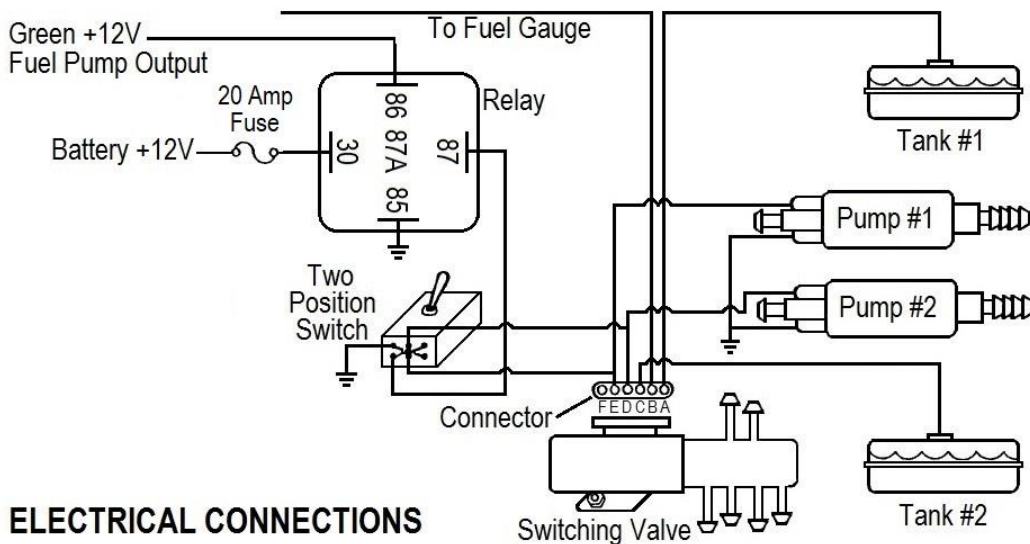

Figure 2

3. Plug the connector into the selection valve. Double check all fuel and electrical connections to be sure they are installed properly. Electrical connections should be insulated and sealed to prevent arcing and corrosion. Check the operation of the selection valve when the system installation is complete.