



CARBURETOR INSTRUCTION SHEET MODELS 4165 & 4175

READ THIS FIRST:

This is a typical view type instruction sheet for different carburetor models, which will show more parts than are required for any one specific model. This kit may also contain universal part assortments resulting in throw away, or an excess in the number of parts that are actually required for servicing any one carburetor. In the case of duplicate gaskets or parts, compare with old pieces. When reassembling the carburetor use the adjustment specifications list to make the necessary adjustments for the list number of your carburetor. Since this instruction sheet cannot contain all the pertinent information required to rebuild your carburetor, Holley recommends the **HOLLEY - REBUILDING AND MODIFYING** book by Jeff William's P/N 36-185. Through out this instruction sheet there will be **WARNINGS** and **NOTES**, Please read these, they contain valuable information that can save you time and money. It is our intent to provide the best possible products for our customers: products that perform properly and satisfy your expectations.

LOCATING THE LIST NUMBER:

The List number for a Model 2010, 2300, 4010, 4011, 4150, 4160, 4165 or 4175 carburetor can be found on the **right side of choke air horn**. The List number for the 4500 can be found on the top of the main body casting. Below the list number is a date code that will contain no more than four (4) digits. See Figure 1 below.



Figure 1

DISASSEMBLY:

Rest the carburetor on a repair stand to avoid damage to the throttle plates during the renew procedures. Use the exploded view, for the model of carburetor you have, as a guide and follow the numerical sequence in general to disassemble unit far enough to permit cleaning and inspection. **DO NOT** remove throttle plates or shaft. Idle limiter: turn the idle limiter cap to its leanest (clockwise) position and remove cap. Observe and Record the initial position of the needle slot. Turn the idle needles clockwise until lightly seated, recording the number of turns required to seat the needles. This procedure is necessary to reinstall the idle needles after renewing the carburetor.

WARNING! Use care not to damage idle adjusting needles when removing idle limiter caps.

CLEANING AND CARE:

Cleaning must be done with carburetor disassembled. Soak parts long enough to soften and remove all foreign material. Use a carburetor solvent, lacquer thinner, or denatured alcohol. Make certain the throttle body is free of all hard carbon deposits. Wash off in suitable solvent. Blow all passages in castings with compress air and check carefully to insure thorough cleaning of obscure areas.

WARNING! **DO NOT** soak parts containing rubber or plastic material. Serious damage could result.

WARNING! Fuel bowls, should only be exposed to carburetor cleaner long enough to permit removal of gum and varnish deposits with a brush. Some fuel bowls have internal "O" Ring seals, which are not removable, but can be damaged by prolonged exposure to some carburetor cleaning solvents.

REASSEMBLY:

Reassemble in reverse order of disassembly. Note the special instructions and follow the calibration numbers in the **SPECIFICATIONS** manual in making final adjustments.

Manually operate the throttle lever and choke mechanism, checking for binding or malfunction. Any binding or interference could cause throttle to stick during operation and result in loss of carburetor throttle control (or uncontrolled engine speed).

WARNING! Check carburetor to be sure there are no leaks, flooding, which might cause a fire.

SPECIAL INSTRUCTIONS FOR ALL CARBURETORS:

IDLE ADJUSTING NEEDLES - Tapered portion of needle must be straight and smooth. If grooved or ridged, a new needle would be install.

PUMP INLET CHECK VALVE - Lubricate tip of new valve and insert in center hole in pump cavity. Pull through from fuel bowl side until seated.

CHOKE PLATE SCREW - Choke plate screws are staked to prevent loosening. To avoid breaking or stripping the threads in the choke shaft, lightly file off the staking. Choke plate screws should be restaked after tightening to prevent loosening.

THROTTLE BODY - **DO NOT** remove throttle shafts or plates. If throttle plates are nicked or damaged, it will be necessary to replace the throttle body.

CHECK BALL - Your kit may contain more than one check ball. The check ball removed from your carburetor should be compared to the new check ball for correct sizing before installation.

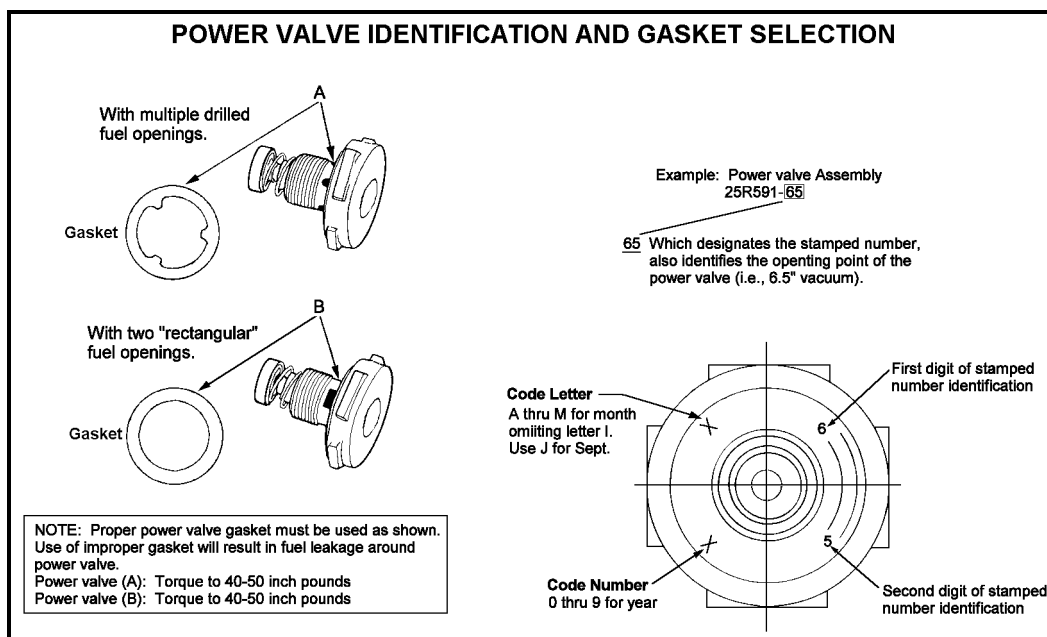

Figure 2

MODELS 4165 and 4175						
<i>List Number</i>	<i>Prim. Dry Float Adj.</i>	<i>Sec. Dry Float Adj.</i>	<i>Pump Cam Primary</i>	<i>Pump Cam Secondary</i>	<i>Choke Qualify</i>	<i>Choke Setting</i>
6210, 6211, 6212, 6263, 6262, 6263, 6468	Parallel	Parallel	#2	#1	.090"	
6210-1, -2, -3, 6211-1, 6468-1, -2, 6854, 8679, 8700	3/16 T	13/64 H	#2		.090"	
6499	Parallel	Parallel	#2	#1	.090"	1NR
6497, 7054	Parallel	Parallel	#2	#1	.070"	2NR
6498, 6772, 6773	Parallel	Parallel	#2	#1	.070"	
6528	Parallel	Parallel	#1	#1	.105"	
6774, 6853, 7002-1, 7004-1, 7005-1, 7006-1, -2, 8302, 8546	3/16 T	13/64 H	#2	#1	.070"	
6926, 6926-1, 7002, 7004, 7005, 7006	Parallel	Parallel	#2		.070"	
7001	parallel	Parallel	#2	#1	.110"	
7351	3/16 T	13/64 H	#2		.096"	Index
7397	3/16 T	13/64 H	#2		.070"	2NR
7855	3/16 T	13/64 H	#2		.086"	
8059, 8059-1	3/16 T	13/64 H	#2		.106"	1NR
8276	3/16 T	13/64 H	#2		.100"	
8879	3/16 T	13/64 H	#2		.080"	
9895, 80073, 80125, 80139, 80140, 80155			#2		.096"	Index
9923			#2		.116"	
9948, 9976, 80128			#2		.120"	1NR
80130-2			#2		.218" - .238"	Index
80328-2, 80390			#2		.200" - .240"	Index
80391			#2		.300± .02	5NL

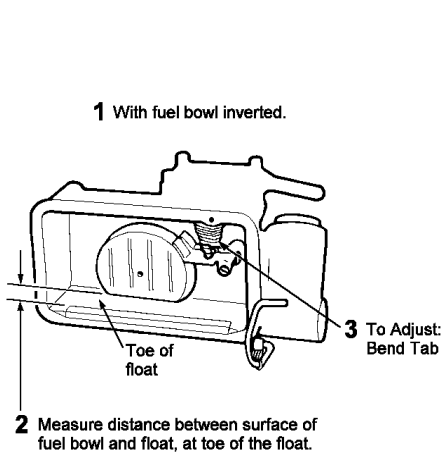

Figure 3
Non-Adjustable Type
Dry Float Setting

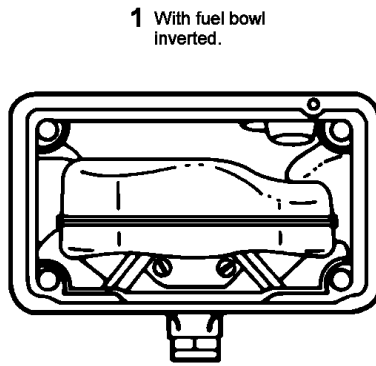
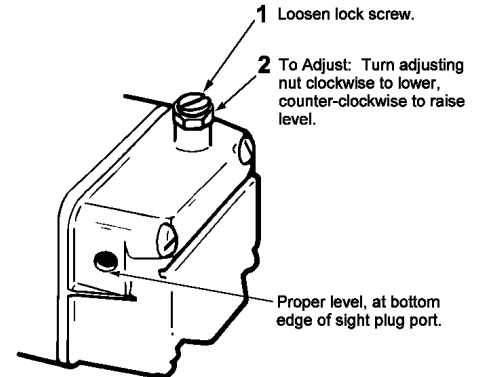

Figure 4
Center Inlet Type
Dry Float Setting



With car on level surface and engine running.

Figure 5
Wet Level Adjustment

NOTE: Spread bore carburetors have been built with two types of main metering body and main body castings.

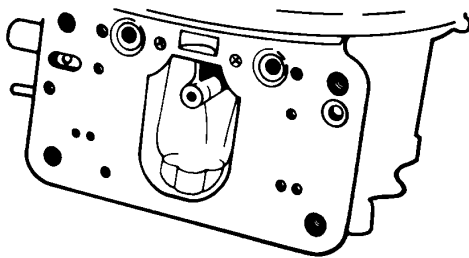

Main body has accelerator pump passage boss flush, or even, with gasket surface for metering body.

Figure 6—Type A

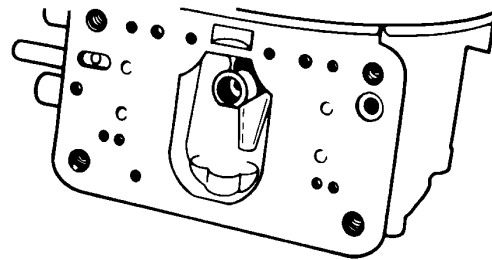

Main body has accelerator pump passage boss recessed .20 (almost 1/4") below gasket face and use connector tube and "O" rings.

Figure 7—Type B

NOTE: If your carburetor is Type A, install the roll pin and the o-ring enclosed.

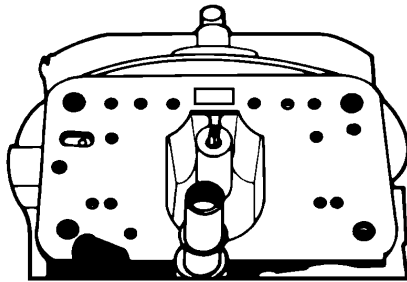

1 Insert split roll pin in accerator pump passage on metering body face of main body. Place washer provided over roll pin into main body until the amount protruding is flush with washer.

Figure 8

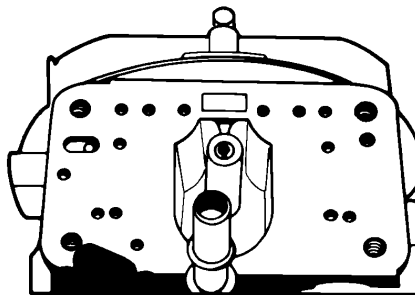

2 Discard washer and place small "O" ring provided over roll pin.

Figure 9

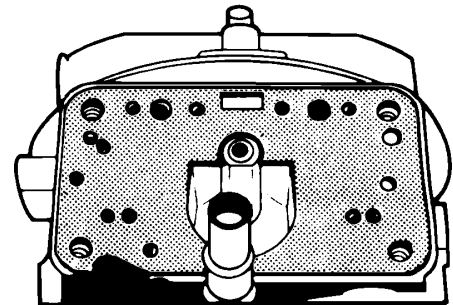

3 Assemble carburetor with new gaskets provided.

Figure 10

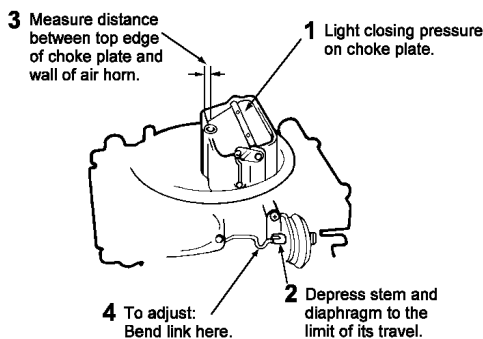

Figure 11

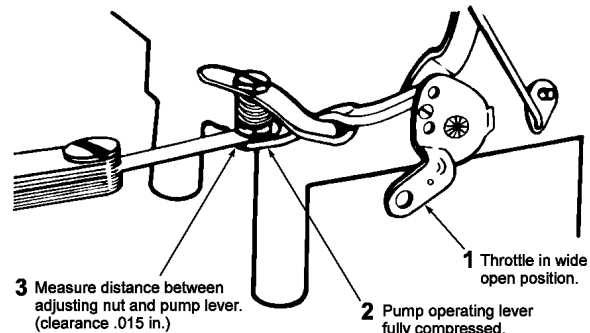

Figure 12

Back the secondary throttle stop screw out until the secondary throttle plates are closed in the throttle bore. Turn the screw in (clockwise) until it just touches the stop on the lever, then give it an additional 1/4 turn.

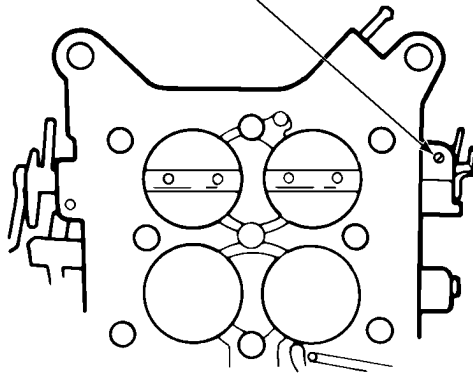
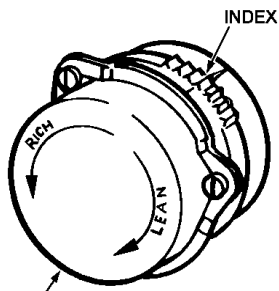

Figure 13



Rotate cover to align reference mark on cover with specified mark on choke housing.

Figure 14

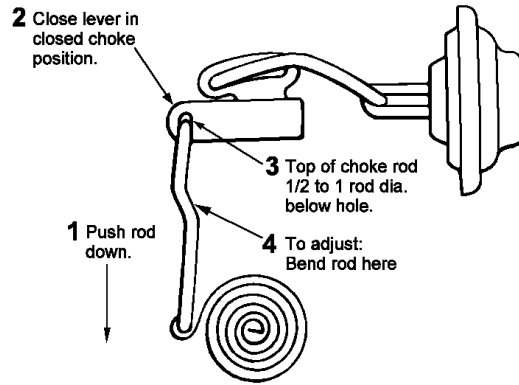
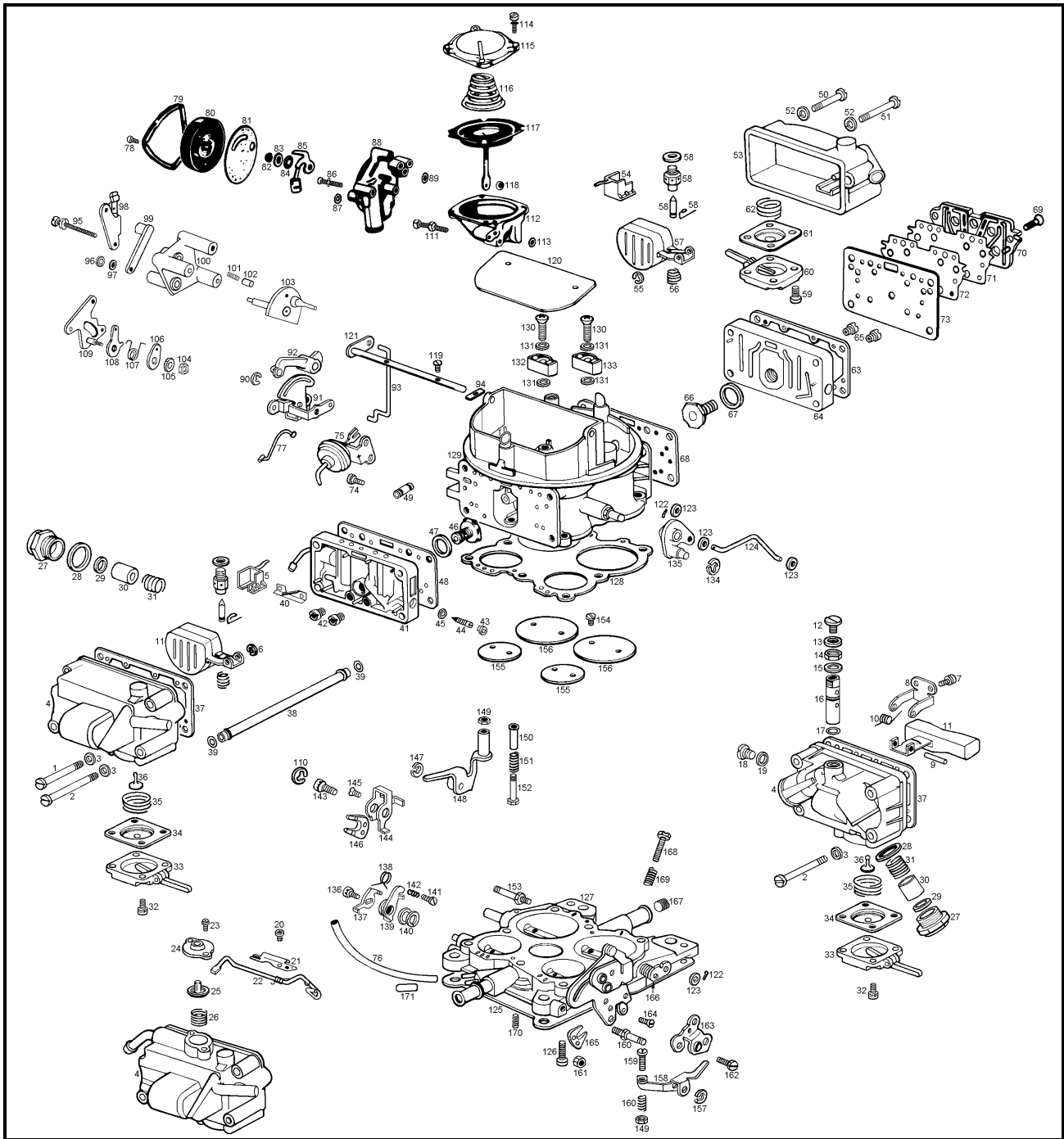

Figure 15



NOMENCLATURE - MODEL 4165 / 4175

Ref. No.	Description	Ref. No.	Description
1	Fuel Bowl Screw (short) Primary	2	Fuel Bowl Screw (long) Primary
3	Fuel Bowl Screw Gasket Primary	4	Fuel Bowl Assembly Primary
5	Baffle Plate Primary	6	Float Retainer Primary
7	Float Shaft Bracket Screw & Lockwasher	8	Float Shaft Retainer Bracket
9	Float Shaft	10	Float Spring
11	Float Assembly Primary	12	Fuel Valve Seat Lock Screw
13	Fuel Valve Seat Lock Screw Gasket	14	Fuel Valve Seat Adjusting Nut
15	Fuel Valve Seat Adjusting Nut Gasket	16	Fuel Inlet Valve & Seat Assembly - Primary
17	Fuel Valve Seat O-Ring Seal	18	Fuel Level Check Plug
19	Fuel Level Check Plug Gasket	20	Vent Rod Clamp Screw & Lockwasher
21	Vent Rod Clamp	22	Vent Rod
23	Vent Valve Screw	24	Vent Valve Clamp Assembly
25	Vent Valve	26	Vent Valve Spring
27	Fuel Inlet fitting	28	Fuel Inlet Fitting Gasket

29	Fuel Inlet Filter Gasket	30	Fuel Inlet Filter
31	Fuel Inlet Filter Spring	32	Accelerator Pump Cover Screw & Lockwasher primary
33	Accelerator Pump Cover Primary	34	Accelerator Pump Diaphragm Assembly Primary
35	Accelerator Pump Diaphragm Spring Primary	36	Accelerator Pump Check Valve Primary
37	Fuel Bowl Gasket Primary	38	Fuel Line Tube
39	Fuel Line Tube O-Ring Seal	40	Metering Body Vent Baffle
41	Metering Body Assembly Primary	42	Main Metering Jet Primary
43	Idle Limiter Cap	44	Idle Adjusting Needle
45	Idle Adjusting Needle Seal	46	Power Valve Assembly Primary
47	Power Valve Gasket Primary	48	Metering Body Gasket Primary
49	Tube & O-Ring Assembly	50	Fuel Bowl Screw (short) Secondary
51	Fuel bowl Screw (long) Secondary	52	Fuel Bowl Screw Gasket Secondary
53	Fuel bowl Assembly Secondary	54	Baffle Plate Secondary
55	Float Retainer Secondary	56	Float Spring
57	Float Assembly Secondary	58	Fuel Inlet Valve & Seat Assembly Secondary
59	Accelerator Pump Cover Screw & Lockwasher Sec.	60	Accelerator Pump Cover Secondary
61	Accelerator Pump Diaphragm Assembly Secondary	62	Accelerator Pump diaphragm Spring Secondary
63	Fuel Bowl Gasket Secondary	64	Metering Body Assembly Secondary
65	Main Metering Jet Secondary	66	Power Valve Assembly Secondary
67	Power Valve gasket Secondary	68	Metering Body Gasket Secondary
69	Secondary Metering Body Screw	70	Secondary Metering Body
71	Secondary metering Body Plate Gasket	72	Secondary Metering Body Plate
73	Secondary Metering Body Gasket	74	Choke Diaphragm Bracket Screw & Lockwasher
75	Choke Diaphragm Assembly	76	Choke Diaphragm Hose
77	Choke Diaphragm Link	78	Thermostat Housing Clamp Screw
79	Thermostat Housing Clamp	80	Thermostat Housing Assembly
81	Thermostat Housing Gasket	82	Thermostat Shaft Nut
83	Thermostat Shaft Nut Lockwasher	84	Thermostat Lever Spacer
85	Thermostat Lever, Link & Piston Assembly	86	Choke Housing Screw
87	Choke Housing Screw Lockwasher	88	Choke Housing Assembly
89	Choke Housing Gasket	90	Choke Control Lever Retainer
91	Choke Control lever and/or Shaft Assembly	92	Fast idle Cam
93	Choke Rod	94	Choke Rod Seal
95	Fast idle Cam Plate Screw & Lockwasher	96	Choke Control Lever Nut
97	Choke Control Lever Lockwasher	98	Choke Wire Bracket
99	Choke Lever & Swivel Assembly	100	Fast Idle Cam Plate
101	Fast Idle Cam Plunger Spring	102	Fast Idle Cam Plunger
103	Fast Idle Cam & Shaft Assembly	104	Back-up Plate Stud Nut
105	Back-up Plate Stud Nut Lockwasher	106	Choke Spring Washer
107	Choke Spring	108	Choke Rod Lever & Bushing Assembly
109	Back-up Plate & Stud Assembly	110	Secondary Diaphragm Link Retainer
111	Diaphragm Housing Screw & Lockwasher	112	Secondary Diaphragm Housing
113	Secondary Diaphragm Housing Gasket	114	Secondary Housing Cover Screw & Lockwasher
115	Secondary Housing Cover	116	Secondary Diaphragm Spring
117	Secondary Diaphragm & Rod Assembly	118	Diaphragm Housing Check Ball
119	Choke Plate Screw	120	Choke Plate
121	Choke Shaft Assembly	122	Secondary Connect Rod Retainer
123	Secondary Connect Rod Washer	124	Secondary Connect Rod
125	Flange Gasket	126	Throttle Body Screw & Lockwasher
127	Throttle Body & Shaft Assembly	128	Throttle Body Gasket
129	Main Body Assembly	130	Pump Discharge Nozzle Screw
131	Pump Discharge Nozzle Gasket	132	Pump Discharge Nozzle Primary
133	Pump Discharge Nozzle Secondary	134	Cam Follower Lever Assembly Retainer
135	Cam Follower Lever Assembly	136	Fast Idle Cam Lever Screw & Lockwasher
137	Fast Idle Pick-up lever	138	Fast Idle Cam lever Spring
139	Fast Idle Cam Lever	140	Throttle Seal Washer
141	Fast Idle Cam Lever Adjusting Screw	142	Fast Idle cam lever Screw Spring
143	Pump Cam Lever Screw & Lockwasher	144	Pump Cam Lever Secondary
145	Pump Cam Screw	146	Pump Cam Secondary
147	Pump Operating Lever Retainer Secondary	148	Pump Operating Lever & Guide Assembly Secondary
149	Pump Operating Lever Adjusting Nut	150	Pump Operating lever Screw Sleeve
151	Pump Lever Adjusting Screw Spring Secondary	152	Pump Operating Lever Adjusting Screw
153	Pump lever Stud Secondary	154	Throttle Plate Screw
155	Throttle Plate Primary	156	Throttle Plate Secondary
157	Pump Operating Lever Retainer Primary	158	Pump Operating Lever Primary
159	Pump Lever Adjusting Screw Primary	160	Pump Lever Stud Primary
161	Throttle Lever Extension Screw Nut	162	Throttle Lever Extension Screw
163	Throttle Lever Extension	164	Pump Cam Screw Primary
165	Throttle Return Spring	166	Throttle Return Spring Secondary
167	Throttle Body Channel Plug	168	Throttle Stop Screw
169	Throttle Stop Screw Spring	170	Pump Lever Adjusting Screw
171	Vacuum Tube Plug		