

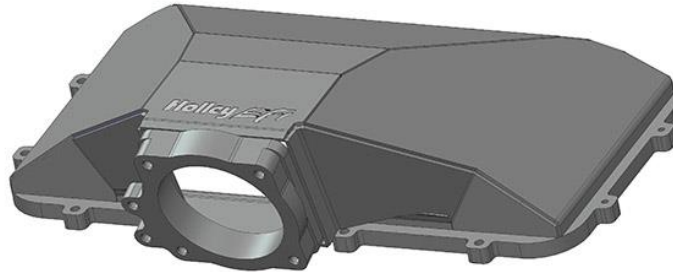

Fabricated 95mm & 105mm Side Entry Plenum Tops for Hi-Ram Manifolds

Holley P/N	Engine Application & Induction Configuration
300-280	Ford 86-95 5.0 95mm, silver
300-281	Ford 86-95 5.0 95mm, black
300-282	Ford 86-95 5.0 105mm, silver
300-283	Ford 86-95 5.0 105mm, black
300-284	GM LS throttle 95mm, silver
300-285	GM LS throttle 105mm, black
300-286	GM LS throttle 95mm, silver
300-287	GM LS throttle 105mm, black



APPLICATIONS:

This Holley Hi-Ram Lid will fit all newer generation Hi-Ram Bases including LS1/LS2/LS6, LS3/L92, LS7, LT1, & FORD 351W & 302W applications. If your existing base is an earlier model, which has clearance holes instead of threaded holes to mount the plenum top, the supplied hardware will not work. 1/4-20 x 1.25" screws with nuts can be used and can be supplied by Holley.

DIMENSIONS:

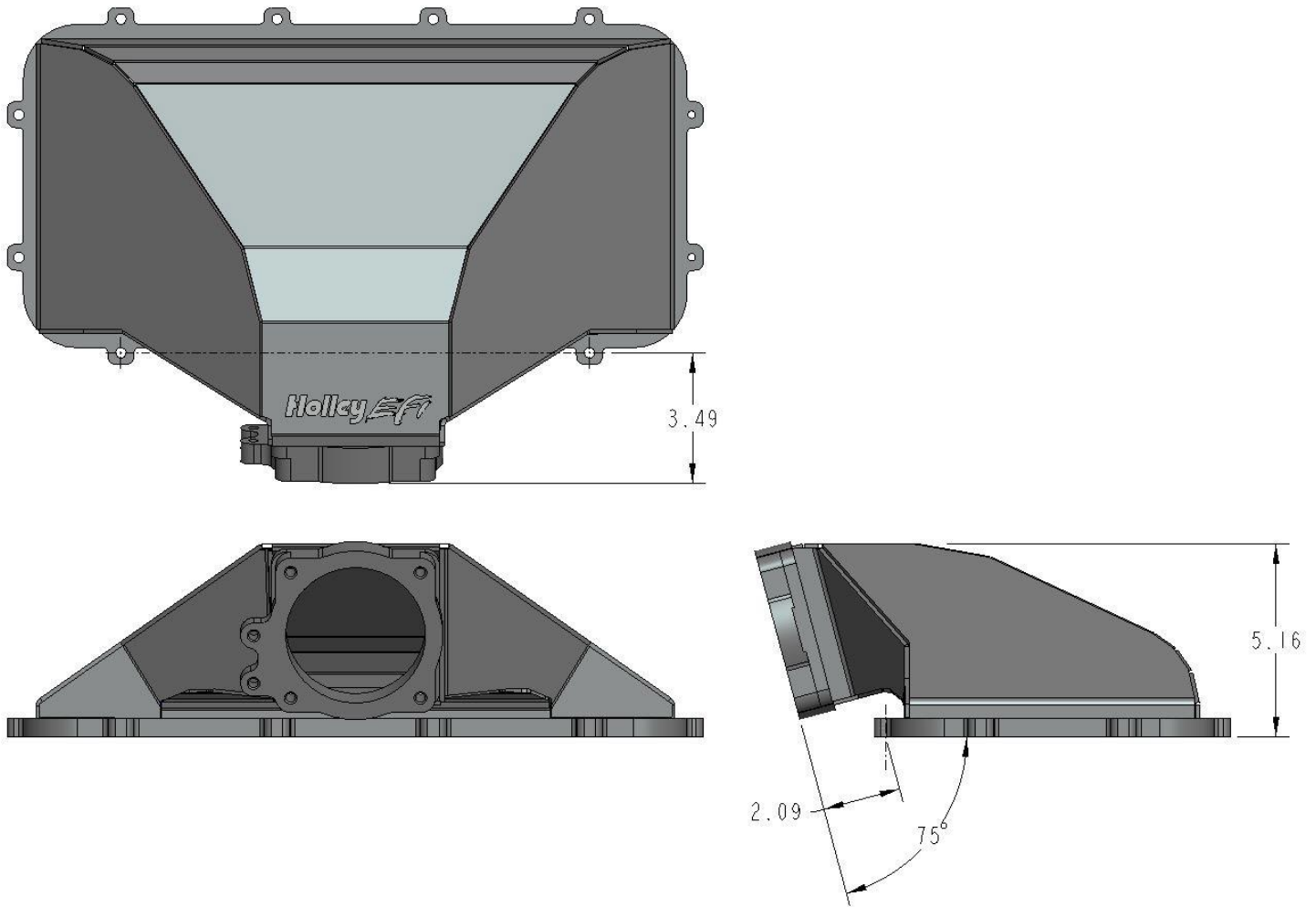

INSTALLATION KIT CONTENTS:

- ❑ 10 – 1/4-20 UNC x 1" Long 12 Point Cap Screws for Plenum Top Attachment
- ❑ 2 – 1/4-20 UNC x 1 3/8" Long Double Ended studs for Plenum Top Attachment
- ❑ 4 – 1/4-20 UNC Hex Nuts, Zinc Plated for Plenum Top Attachment
- ❑ 12 – 1/4" Flat Washers for Throttle Valve Attachment
- ❑ 4 – 5/16" Flat Washers for Throttle Valve Attachment
- ❑ 4 – 5/16" Double Ended Studs for Throttle Valve Attachment
- ❑ 4 – 5/16-24 UNC Hex Nuts for Throttle Valve Attachment
- ❑ 1 – Throttle Valve Gasket

INSTALLATION OF PLENUM TOP:

1. Before installing the plenum top, the O-ring cord supplied with your Holley Hi-Ram base manifold will need to be cut to length and glued together.
2. Lay the O-ring cord into the groove on the plenum flange of the base manifold with the free end overlapped.
3. Mark the position of the cut to be made across both O-ring ends.
4. Lay the O-ring on a flat surface with the ends overlapped and the marks aligned as they were when the marks were made.
5. With a sharp razor blade cut thru both ends of the O-ring at the mark simultaneously.
6. With a drop of super glue (Cyanoacrylate), bond the ends of the O-ring together. The glued joint should be smooth, not offset or kinked.

7. To ensure sealing at the glued joint, apply a thin film of silicone sealer around the O-ring at the glued joint, allowing the silicone to partially cure before installation of the O-ring in the groove.
8. Install the O-ring in the groove on the base manifold plenum flange. Place the plenum top in place.
9. Apply blue thread locking compound onto one end of each 1/4-20 double ended studs. Install this end into the base manifold holes that will be located under the throttle valve. Leave about 7/16" of each stud exposed.
10. Place the plenum top over the two studs onto the flange of the base manifold.
11. Place one washer and one hex nut onto each stud. The nuts should be finger tight only at this time.
12. Apply a drop of engine oil to the threads of the ten 1/4-20 mounting screws and install finger tight with the supplied washers into the remaining mounting holes.
13. Gently tighten the fasteners evenly, using the sequence shown below, in two steps. Tighten all of the fasteners to 45 in-lbs for the first step, then torque to 90 in-lbs.

TORQUE SEQUENCE:

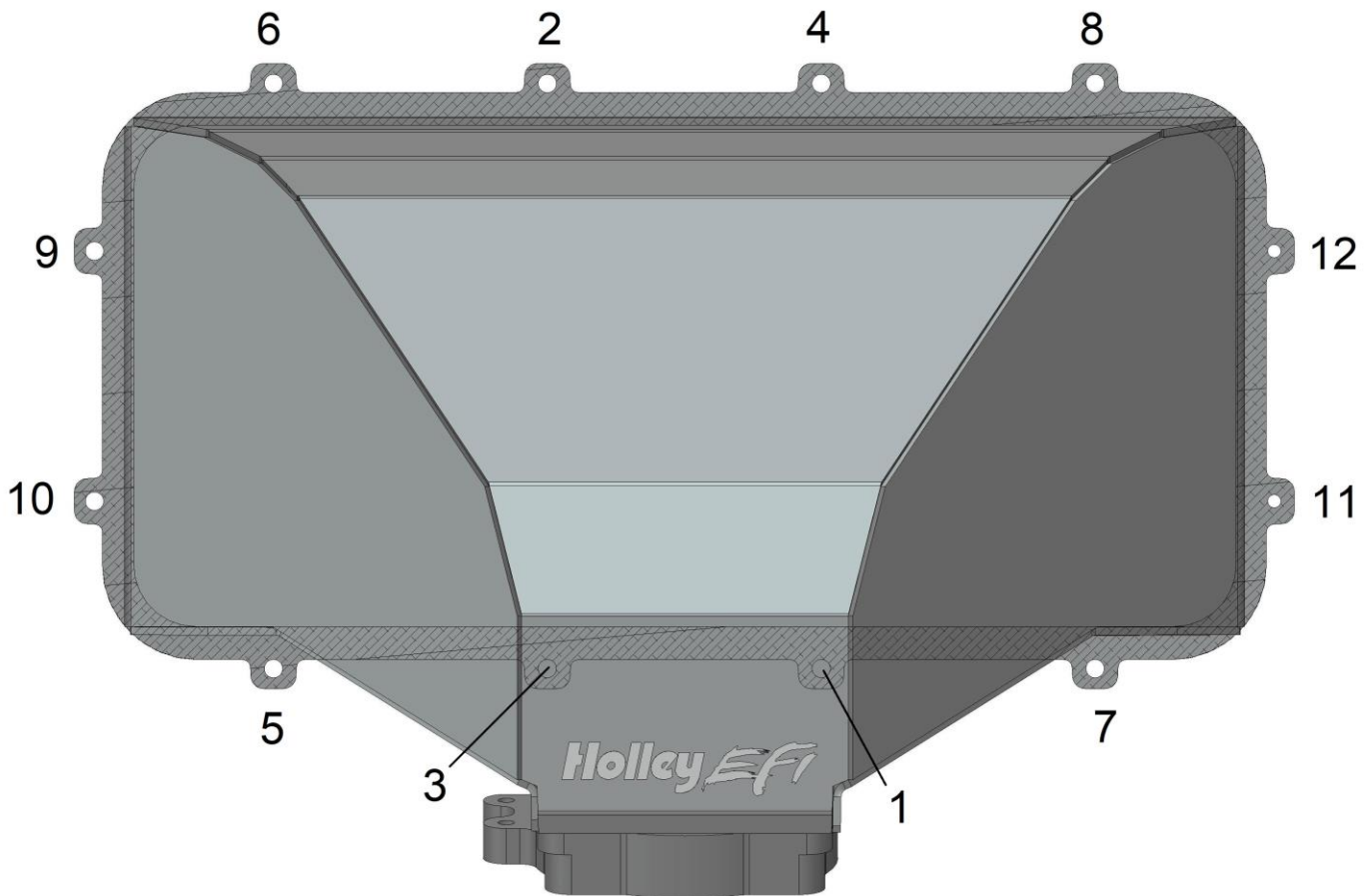

SERVICE PARTS & ACCESSORIES AVAILABLE SEPARATELY:

Service Parts

- 508-40** – Replacement Hardware Kit, Cast Side Entry Hi-Ram Lid
- 508-20** – Throttle Body Gasket, 92mm or 102mm LS Throttle Body
- 508-24** – Throttle Body Gasket, 105mm LS Throttle Body
- 508-21** – Hi-Ram Plenum O-Ring Cord, 3/32" Round, Viton, 4.5' Long
- 508-26** – Throttle Body Gasket, 105mm Ford 5.0L

Accessories

- 20-148** – Throttle Cable Bracket For 105mm GM Style Throttle Bodies
- 20-147** – Throttle Cable Bracket For 90-95mm GM Style Throttle Bodies

HI-RAM BASE MANIFOLDS AVAILABLE SEPARATELY:

Hi-Ram Base Manifolds

- 300-227** – GM LS1/LS2/LS6 Cathedral Port EFI Base Only
- 300-214** – GM LS3/L92 EFI Base Only
- 300-229** – GM LS7 EFI Base Only
- 300-236** – GM LT1 Base Only with Port Injection
- 300-237** – GM LT1 Base Only without Port Injection
- 300-244** – Ford 351W EFI Base Only
- 300-274** – Ford 302 EFI Base Only