



## Holley Ford 302 (8.2" Deck – Windsor) Hi-Ram Modular Intake Manifold Kits

Holley P/N	Engine Application & Induction Configuration
300-272	Hi-Ram, 1 x 95mm LS Throttle Body (longitudinal mount) w/ port EFI provisions & fuel rails
300-273	Hi-Ram, 1 x 105mm LS Throttle Body (longitudinal mount) w/ port EFI provisions & fuel rails
300-274	Hi-Ram, Base Manifold Only, carbureted
300-275	Hi-Ram, Base Manifold Only, w/ port EFI provisions & fuel rails

### INSTALLATION INSTRUCTIONS 199R11758

(Before installation, please read these instructions completely.)

### APPLICATIONS:

This Holley Hi-Ram intake manifold series is designed for Ford Windsor engines with an 8.2" deck height. This intake manifold is designed for use with aftermarket cylinder heads.

This Hi-Ram style intake manifold is designed for high performance engine applications using large displacements and maximum engine speeds of 7500-8500 rpm, depending on the engine combination. The Hi-Ram intake manifold is intended for maximum performance applications and will not accept stock components and hardware. A modified hood will be required for most vehicle applications.

### EMISSIONS EQUIPMENT:

Holley Hi-Ram intake manifolds do not accept any emission-control devices. This part is not legal for sale or use for motor vehicles with pollution-controlled equipment.

### DIMENSIONS:

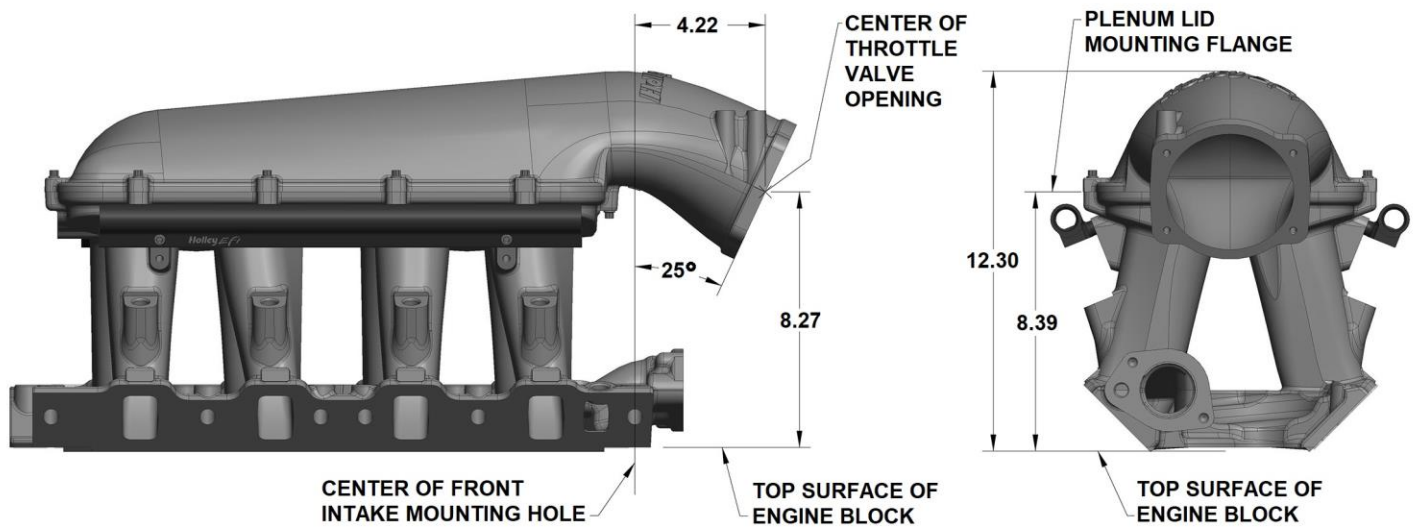

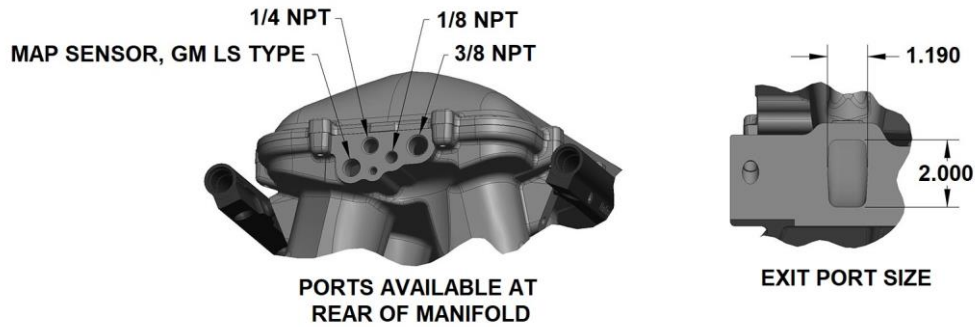
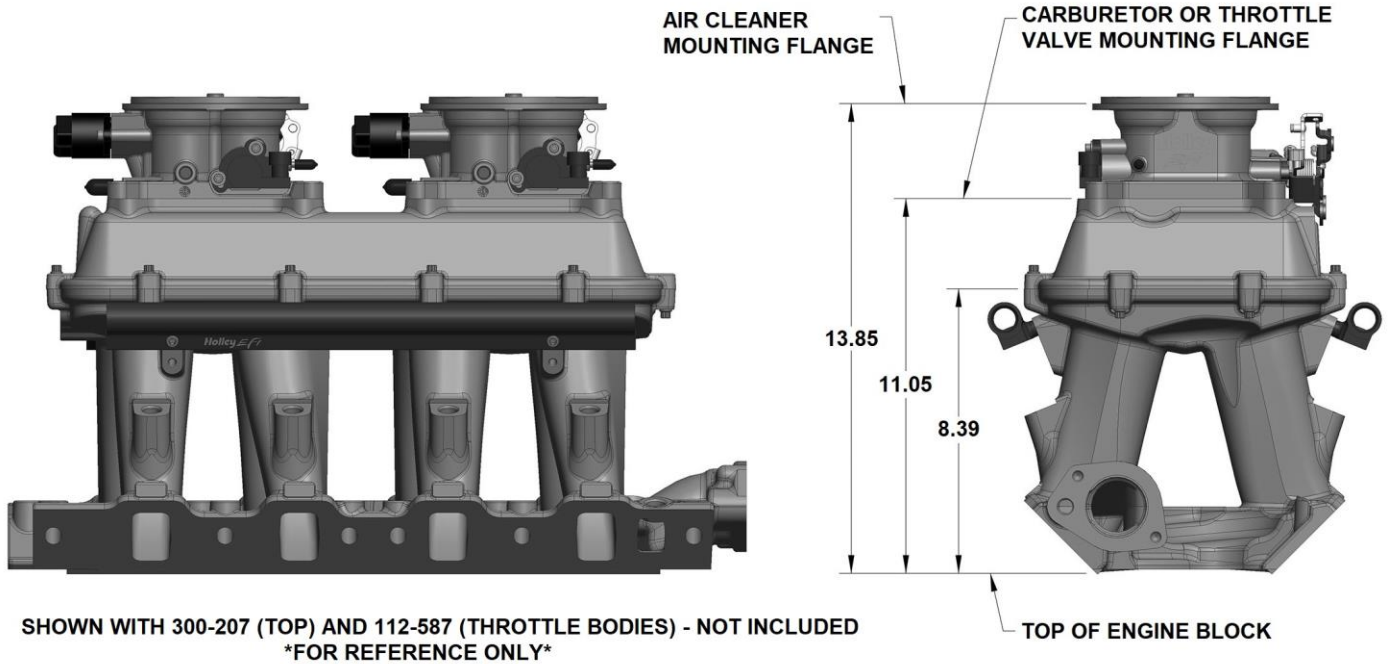

## INSTALLATION KIT CONTENTS:

- ❑ 12 – 1/4-20 UNC x 1” Long 12 Point Cap Screws, Zinc Plated, Plenum Attachment Bolts
- ❑ 4.5 ft – O-ring Cord, 3/32” Dia. Round Section Viton, Plenum Flange Seal, Holley Service P/N 508-21
- ❑ 12 – Studs, 5/16-18 Threads, Intake Manifold to Cylinder Head Mounting
- ❑ 12 – Washers, 5/16, Intake Manifold to Cylinder Head Mounting
- ❑ 1 – 1/8 NPT Hex Steel Pipe Plug
- ❑ 3 – 3/8 NPT Hex Steel Pipe Plugs
- ❑ 12 – Nuts, 5/16-18
- ❑ 12 – 1/4” Washers, Plenum Lid Mounting
- ❑ 1 – 1/4 NPT Steel Pipe Plug
- ❑ 1 – Warranty Card
- ❑ MAP Sensor Port Cover

## FUEL RAIL KIT CONTENTS:

(Fuel Rail Kit P/N 534-257 – included in 300-272, 300-273, & 300-275)

- ❑ 2 – Fuel Rail, High Volume, Configured with 3/4-16 O-ring Ports (AN-8)
- ❑ 4 – 1/4-28 UNC x 1.25” Long Socket Head Cap Screws, Zinc Plated, Fuel Rail Mounting
- ❑ 8 – O-Ring, Fuel Injector to Intake Manifold Seal

## EFI PLENUM TOP, 1 x 95mm/105mm LS THROTTLE BODY, KIT CONTENTS:

(included in 300-272 & 300-273)

- ❑ 1 – Gasket, 95mm or 105mm LS Throttle Body, Holley Service (P/N 508-20 for 95mm or 508-24 for 105mm)

## INSTALLATION INSTRUCTIONS:

### Installation on Modified Engine Components –

The Hi-Ram modular intake manifolds are designed to provide maximum performance for racing engines. The intake manifold will have the best fitment when the engine block and cylinder heads are machined to standard OE dimensions. If the engine block or cylinder head deck surfaces have been milled significantly, the mounting bolt holes and the port flange openings to the cylinder head might not align. If your engine has had the cylinder head or engine block deck surfaces milled, the following may be necessary for proper intake manifold installation.

- The bolt holes in the intake manifold would have to be slotted to allow the fastener to properly pass through the manifold mounting holes.
- The mounting fasteners must freely thread into the cylinder head while passing through the mounting holes or the manifold may not seat properly onto the cylinder head surfaces when the fasteners are tightened.

### Installation of the Intake Manifold Base –

1. Before installing the intake manifold base, buy a set of intake manifold gaskets (Mr. Gasket 22300G is recommended). Perform a test fit of the intake manifold with the gaskets in position. Make sure that the mounting studs supplied can thread freely into the cylinder heads through the intake manifold mounting holes. The mounting flange should seat properly.
2. Check the port opening alignment. Test fit the plenum top, fuel and vacuum plumbing, throttle linkage, wiring, etc. to ensure there are not any fit issues before performing the final intake manifold installation.
3. Install the mounting studs into the cylinder heads. Apply engine oil to the threads and thread in the stud until all of the threads are engaged by hand.
4. Put the manifold gaskets into place on the mounting flanges. Set the manifold base over the studs.
5. Install the washers and nuts provided (engine oil should be applied to the threads). Using the sequence shown, tighten each nut in several stages. Set final torque to 15-18 ft./lbs.

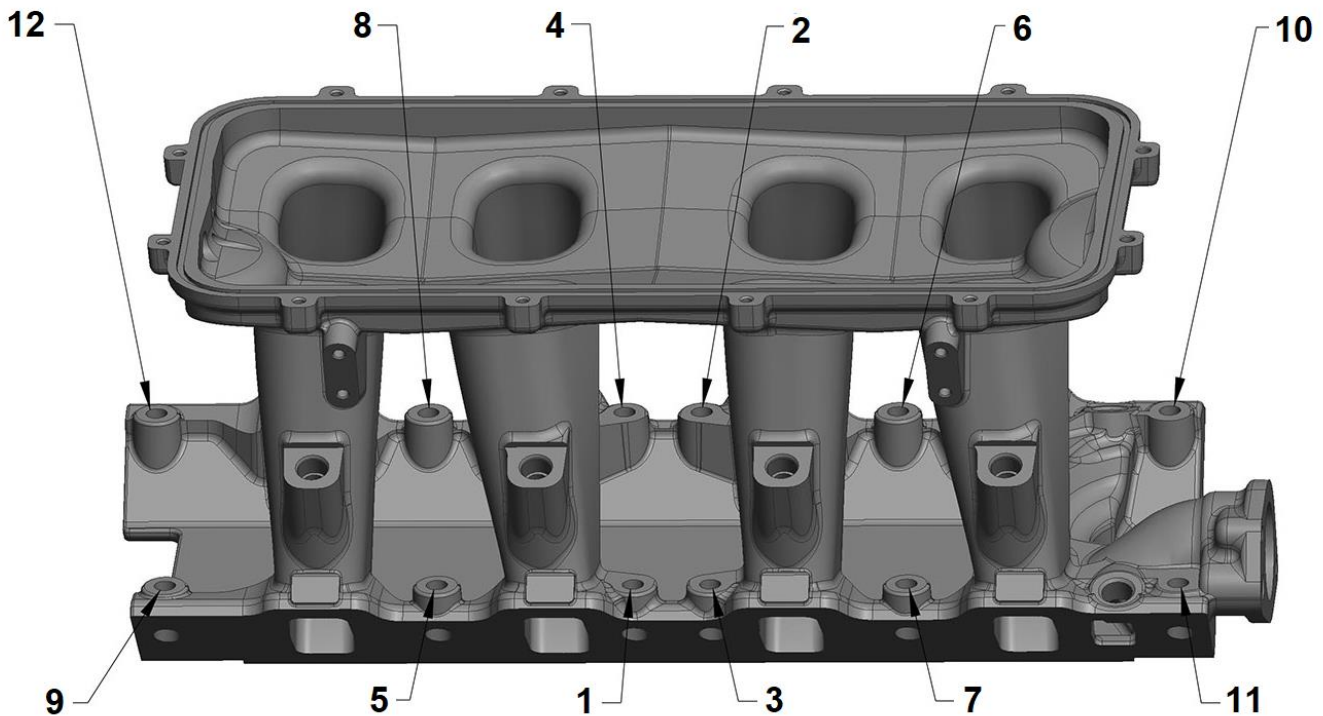

**Manifold Tightening Sequence**

6. There is a flange on the rear of the base manifold for vacuum source. There is one 1/8 NPT port, one 1/4 NPT port, one 3/8 NPT port, and a port for a GM LS3 style MAP sensor. If the GM MAP sensor won't be used, a port cover is provided.

## Installation of the Plenum Top –

1. Before installing the plenum top, the supplied O-ring cord will need to be cut to length and glued together.
2. Lay the O-ring cord into the groove on the plenum flange of the base manifold with the free end overlapped.
3. Mark the position of the cut to be made across both O-ring ends.
4. Lay the O-ring on a flat surface with the ends overlapped and the marks aligned as they were when the marks were made.
5. With a sharp razor blade cut thru both ends of the O-ring at the mark simultaneously.
6. With a drop of super glue (Cyanoacrylate), bond the ends of the O-ring together. The glued joint should be smooth, not offset or kinked.
7. To ensure sealing at the glued joint, apply a thin film of silicone sealer around the O-ring at the glued joint, allowing the silicone to partially cure before installation of the O-ring in the groove.
8. Install the O-ring in the groove on the base manifold plenum flange. Place the plenum top in place.
9. Apply a drop of engine oil to the supplied ¼-20 UNC x 1" 12 point cap screws and install finger-tight with supplied washers.
10. Gently tighten the fasteners evenly - starting from the middle of the sides, crossing side to side, and moving towards the ends until the plenum top is seated and the O-ring is compressed. Tighten the fasteners in two steps using the tightening pattern shown in the figure below. Tighten to 45 in-lbs for the first step and 90 in-lbs for the second step.

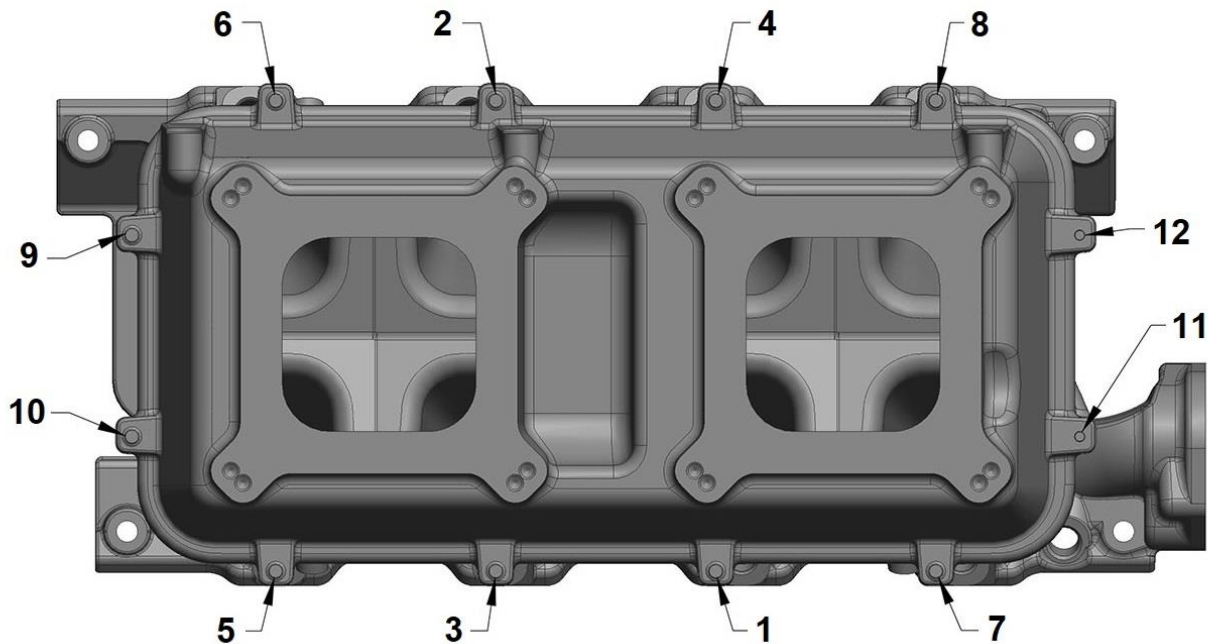

**Plenum Top Tightening Sequence  
(P/N 300-207 shown – not included)**

## Installation of the Fuel Rails –

P/N's 300-272, 300-273, & 300-275 include a fuel rail kit (P/N 534-257). The fuel rail mounting pads have two sets of holes. The top holes position the fuel rail to install a standard Bosch style EV-1 fuel injector. The bottom set of holes position the fuel rail to install the GM LS7 type fuel injector.

1. The provided O-rings are for use with GM LS7 style fuel injectors. If using GM LS7 injectors, remove the O-ring from the outlet end of each injector and replace with the O-ring provided in this kit. If using Bosch EV-1 style injectors, the provided O-rings are not needed.
2. Apply a silicone lubricant to the O-ring on the inlet end of fuel injectors and insert the fuel injectors into the ports in the fuel rail. To insert the injector without tearing the O-ring, gently rock the injector in the inlet of the port while applying pressure to insert the injector.
3. Position the injectors to properly orient the wiring plugs, apply silicone lubricant to the injector outlet O-rings, and insert all four injectors into injector bosses in the base intake manifold applying gentle downward pressure on the fuel rail.
4. Once the injectors are inserted into the intake manifold, apply a drop of oil to the ¼-28 x 1.25" long socket head cap screws.
5. Then, use these screws to assemble the fuel rail to the manifold base.
6. Tighten the fuel rail mounting fasteners in two steps - 75 in-lbs for the first step and 130 in-lbs for the second step.
7. Check and make sure the injector is floating on the O-ring. Rotate the injector back and forth to confirm that there is no load on the injector body.
8. The fuel rail is designed to provide enough flow and volume to dampen fuel pressure oscillations and variations at the inlet of the fuel injectors. The fuel rails are machined to receive an adapter fitting for ¾-16 (AN-8) O-ring port.
  - For power levels below 700-750HP, AN-6 (3/8") plumbing to and from the fuel rails should be sufficient.
  - For power levels above 750HP, AN-8 (1/2") plumbing is recommended.
  - It is always recommended to only use tubular hose ends when a non-straight hose end is required.
  - The best configuration for plumbing the fuel rails is to split from the supply line with a "Y" type distribution block or fitting, then feed into the inlet end of each fuel rail. The hoses from the exit end of each fuel rail would then feed into each inlet port of a fuel pressure regulator with two inlet ports or into another "Y" type distribution block or fitting connecting to a hose leading to the fuel pressure regulator.

## Installation of Carburetors or Throttle Bodies –

1. When installing the carburetors or throttle bodies and the connecting throttle linkage, check to be sure that all throttle levers and linkage components have adequate clearance from the intake manifold and plenum top components.
2. The plenum tops for the 2 x 4500 and 2 x 4150 carburetor configurations have bosses for the mounting of throttle linkage. The three bosses are positioned for the mounting of heim joints that would carry a throttle linkage motion transfer shaft.
3. The EFI 1 x 95mm and 1 x 105mm LS throttle body plenum tops provide bosses near the throttle body flange for the mounting of a throttle cable bracket. The bracket will need to be fabricated by the user for each individual throttle cable and throttle body application. It should be noted that the throttle body flange on this plenum top may fit with a GM LS3 drive by wire throttle body.

## **HI-RAM PLENUM TOPS AND SERVICE PARTS AVAILABLE SEPARATELY:**

### ***Plenum Tops***

300-207 – 2 x 4150, up to 1.75" bores, (sideways mount 4150, inline mount 4160)

300-208 – Blank Flange Configurable Top

300-245 – 1 x 95mm LS Throttle Body, Longitudinal Mount

300-246 – 1 x 105mm LS Throttle Body, Longitudinal Mount

### ***Fuel Rail Kits***

534-257 – 302W Hi-Ram Fuel Rail Kit, High Volume, 3/4-16 O-ring Port (AN-8) Connection

534-206 – Fuel Rail Extrusion, Raw, 12" Long, High Volume

534-207 – Fuel Rail Extrusion, Raw, 18" Long, High Volume

534-208 – Fuel Rail Extrusion, Raw, 36" Long, High Volume

### ***Fabrication Flanges***

300-211 – Hi-Ram Plenum Fabrication Flange, 0.50" Billet Machined Aluminum Plate

300-221 – Hi-Ram 92mm LS Throttle Body Fabrication Flange, 0.50" Billet Machined Aluminum Plate

300-222 – Hi-Ram 102mm LS Throttle Body Fabrication Flange, 0.50" Billet Machined Aluminum Plate

### ***Service Parts***

508-20 – Throttle Body Gasket, 92mm or 102mm LS Throttle Body

508-24 – Throttle Body Gasket, 105mm LS Throttle Body

508-21 – Hi-Ram Plenum O-Ring Cord, 3/32" Round, Viton, 4.5' Long

300-252 – Stud Kit, 302W Hi-Ram Base Intake Manifold Mounting

534-104 – Fuel Injector O-rings, set of 16 (for use with GM LS7 injector)

### ***Gaskets***

22300G – Intake Manifold Gasket Set (1.40" x 2.25" ports .093" thick)