



## P/N 300-224 – Holley Hi-Ram Intake Manifold Mounting Stud Kit for GM Gen V LT1 Engines

### Contents:

- Studs, M6 x 1.0 Threads, Intake Manifold to Cylinder Head Mounting, qty-10
- Washers, M6 x 12mm O.D x 1.6mm Thick, Intake Manifold to Cylinder Head Mounting, qty-10
- Nuts, M6 x 1.0 Threads, Intake Manifold to Cylinder Head Mounting, qty-10

### INSTALLATION INSTRUCTIONS

(Before installation, please read these instructions completely.)

1. Before installing the intake manifold base, perform a test fit of the intake manifold without the O-rings installed. Make sure that the mounting studs (supplied) can thread freely into the cylinder heads through the intake manifold mounting holes. The mounting flanges should seat properly. Check the port opening alignment. Test fit the plenum top, fuel and vacuum plumbing, throttle linkage, wiring, etc. to ensure there are not any fit issues before performing the final intake manifold installation.
2. For final installation, install eight O-rings in the mounting flange O-ring grooves. To help install the O-rings into the grooves, apply a light coat of grease to the O-rings.
3. Place the manifold base in place on the mounting flange. Be sure that all of the O-rings are still in the grooves and are not being crushed between the flanges.

**WARNING! The M6x1 threads in the aluminum cylinder head will not withstand abuse. Care must be taken to have proper thread engagement and to tighten the fasteners to the proper specifications.**

4. Install the washers and nuts provided; engine oil should be applied to the threads. Gently tighten the nuts working side to side and out from center (see the tightening sequence diagram below), until manifold is seated on the mounting flanges and the O-rings have been compressed. In two steps, tighten the mounting nuts first to 44 in-lbs and then to 89 in-lbs following the tightening sequence diagram below.

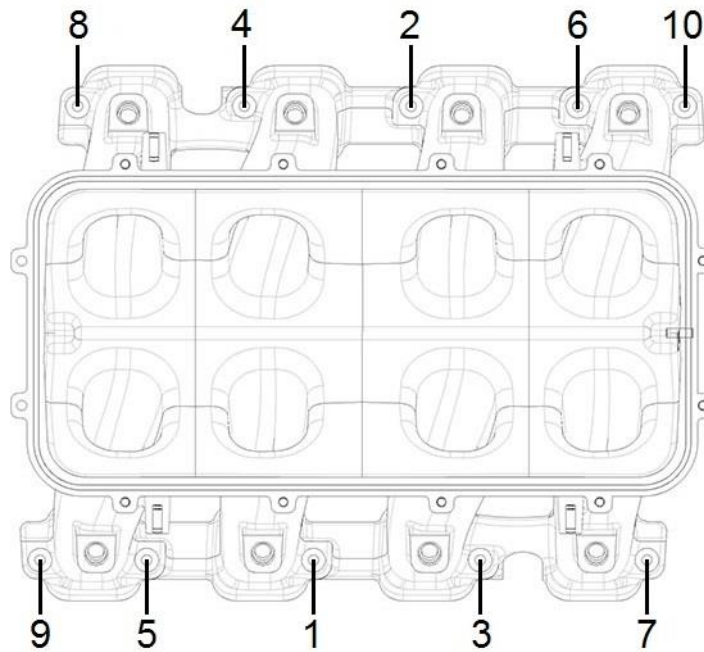

Manifold Tightening Sequence