



OFF VEHICLE CARBURETOR SERVICE HOLLEY MODEL – 4180C REBUILD KIT 3-1346

INSTRUCTION SHEET 199R10060

DISASSEMBLY:

Use the exploded view as a guide. The numerical sequence may generally be followed to disassemble the unit far enough to permit cleaning and inspection. **NOTE:** The choke plate retaining screws are staked at the threaded end and this staking must be filed off before removing screws. Be careful not to damage the choke shaft or venture while filing the screws.

To remove the choke cover retainer tamper proof screws, carefully hacksaw a slot in the head of the screw deep enough to accommodate a screwdriver bit. Carefully remove the screws with a screwdriver.

Identify the primary and secondary floats as they are removed from the fuel bowls, for proper reassembly.

To remove the primary and secondary idle mixture concealment plugs, center punch and drill 3/32" diameter hole through the hardened steel plug. Install an easy out and remove the plug. Before removing the idle adjusting needles, carefully turn the needles in clockwise, counting the number of turns it takes to lightly seat the needles. Record for proper reassembly.

CLEANING:

Cleaning must be done with carburetor disassembled. Soak parts long enough to soften and remove all foreign material using cold immersion type carburetor cleaner. Make certain the throttle bores are free of all carbon and varnish deposits. Rinse off in a suitable solvent. Blow out all passages in the castings with compressed air and check carefully to ensure thorough cleaning of obscure areas. **CAUTION:** Do not soak assemblies with attached plastic parts for a long period of time. Do not soak any parts containing rubber, floats, or diaphragm assemblies.

REASSEMBLY:

Reassemble the carburetor using the reverse order of disassembly. **NOTE:** Special instructions and follow numerical outline in making adjustments necessary for the carburetor being serviced.

SPECIAL INSTRUCTIONS:

Pump discharge check needle (79) – replace with steel ball. Install ball, then using a brass punch and hammer, stake the ball for a good seat.

Pump Nozzle (78) and screw (76) installation – tighten screw securely. Using a flat punch and hammer, restake the nozzle screw in position. Care should be used when staking the nozzle so as not to use excessive force. Remove any chips from the carburetor assembly. See **Figure 1**.

Choke plate screws (71) – stake screws after installation.

Primary idle adjusting needles (67) – turn in until lightly seated, then back out the number of turns recorded on disassembly. Do not install the idle needle concealment plugs at this time.

Screws listed below must be tightened in three stages crosswise to arrive at the correct torque.

Throttle body gasket (65) – be sure the holes are properly matched to the throttle body. Torque throttle body screws to 50 in./lbs.

Enrichment valve (58) – install with gasket and torque to 100 in./lbs.

Primary & secondary fuel bowl (43) & (23) – before installing, make dry float level adjustment.

Bowl screw installation (41 & 21) – install gaskets (42 & 22) on screws before installing, then torque evenly in stages to 50 in./lbs.

Fuel line tube (35) – install o-rings (36) on the extreme ends of the tube. They will roll on the tube when installing the fuel bowls.

O-rings – lubricate lightly before installing.

#	Description	#	Description	#	Description
1	Screw (2) - Solo Pot	28	Plug - Fuel Level	55	Gasket - Primary Fuel Bowl
2	Solo Pot Assy.	29	Gasket - Plug	56	Metering Body - Primary
3	Screw (2) - Retainer	30	Screw (6) - Sec. Metering Body	57	Jet (2) - Main
4	Screw (1) - Retainer	31	Metering Body - Secondary	58	Valve - Primary Enrichment
5	Retainer - Choke Cover	32	Gasket - Metering Body	59	Gasket - Primary Enrichment Valve
6	Choke Cover Assy.	33	Plate - Metering Body	60	Gasket - Primary Metering Body
7	Gasket - Choke Cover	34	Gasket - Fuel Bowl & Metering Body	61	Tube - Pump Passage
8	Retainer - Choke Rod	35	Tube - Fuel Line	62	O-ring (2) - Passage Tube
9	Screw & Lckwshr (3) Choke Housing	36	O-ring (2) - Fuel Line Tube	63	Screw & Lckwshr (6) - Throttle Body
10	Choke Housing Assy.	37	Screw & Lckwshr (4) - Pump Cover	64	Assy - Throttle Body
11	Gasket - Choke Housing (o-ring) 84-85	38	Cover Assy - Pump Diaphragm	65	Gasket - Throttle Body
12	Retainer - Sec. Diaphragm Link	39	Diaphragm - Pump	66	Plug (2) - Primary Idle Needle
13	Screw & Lckwshr (3) Sec. Dia. Housing	40	Spring - Pump Diaphragm	67	Needle (2) - Primary Idle Adjusting
14	Sec. Diaphragm Housing Assy.	41	Screw (4) - Primary Fuel Bowl	68	O-ring (2) - Primary Idle Needle
15	Gasket - Sec. Dia. Hsg (o-ring) 84-85	42	Gasket (4) - Primary Bowl Screw	69	Spring (2) - Primary Idle Adj. Needle
16	Screw & Lckwshr (4) Cover	43	Bowl Assy - Primary	70	Assy - Main Body
17	Cover - Sec. Diaphragm	44	Needle & Seat Assy - Primary	71	Screw (2) - Choke Plate
18	Spring - Sec. Diaphragm	45	Baffle - Primary Fuel	72	Plate - Choke
19	Diaphragm - Secondary	46	Retainer - Primary Float	73	Shaft - Choke Plate
20	Ball - Sec. Diaphragm Check	47	Float & Spring Assy - Pri.	74	Rod - Choke
21	Screw (4) - Sec. Fuel Bowl	48	Plug - Fuel Level	75	Seal - Choke Rod
22	Gasket (4) - Sec. Bowl Screw	49	Gasket - Plug	76	Screw - Pump Nozzle
23	Bowl Assy. - Sec. Fuel	50	Fitting - Fuel Inlet	77	Gasket (2) - Pump Nozzle
24	Needle & Seat Assy. - Sec.	51	Gasket - Fitting	78	Nozzle - Pump Disc
25	Baffle - Sec. Fuel	52	Gasket - Filter	79	Needle - Pump Disc Check
26	Retainer - Sec. Float	53	Filter - Fuel		
27	Float & Spring Assy. - Sec.	54	Spring - Filter		

GENERAL EXPLODED VIEW

The general design & parts shown will vary from parts covered in this instruction sheet.

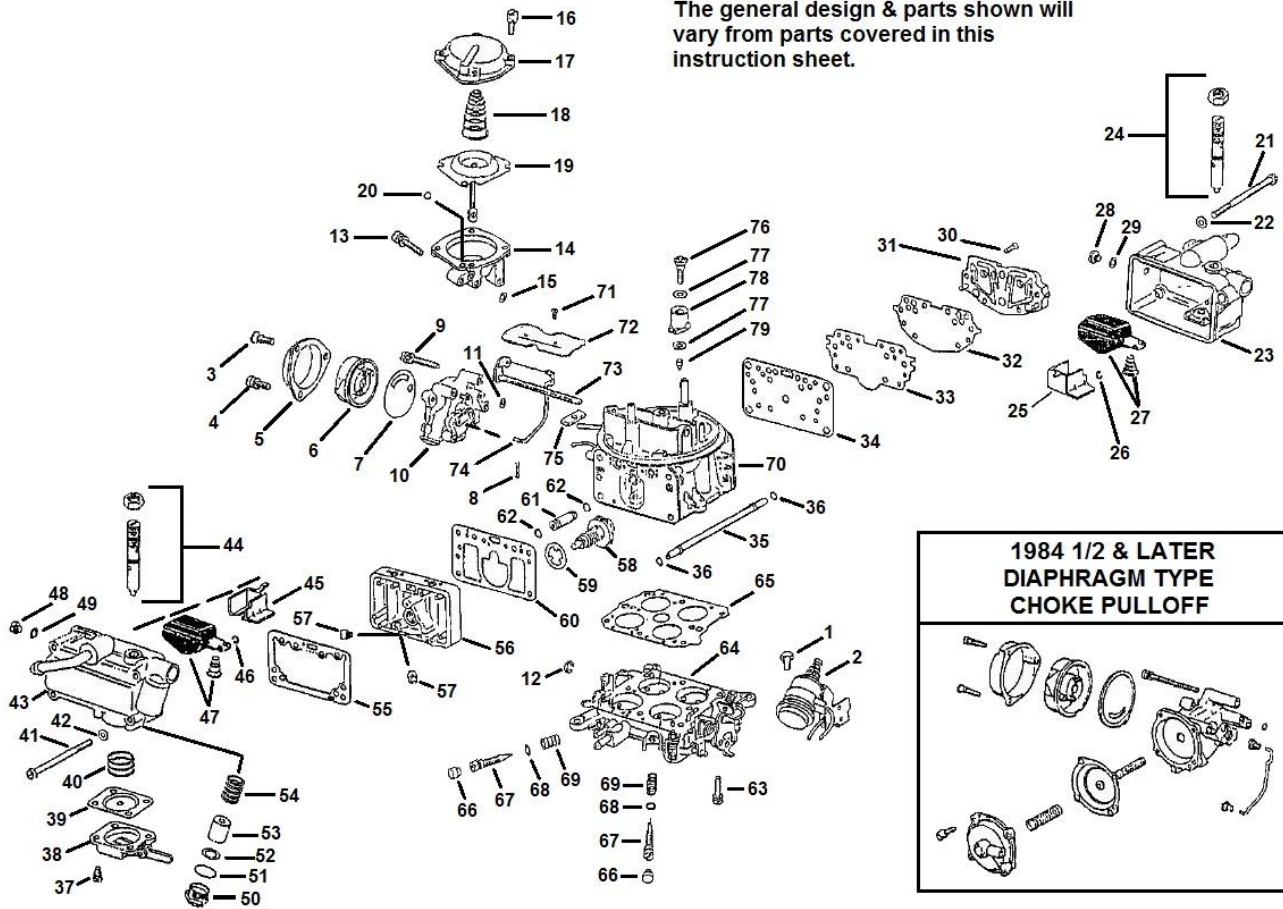

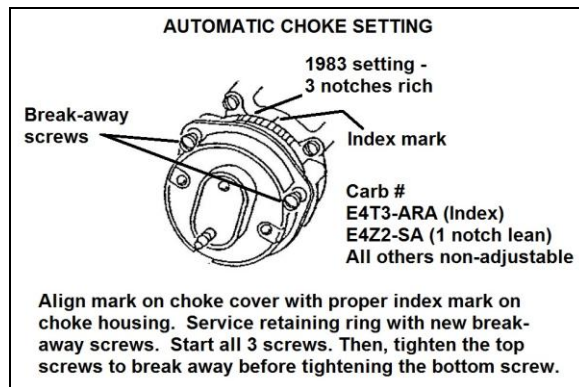
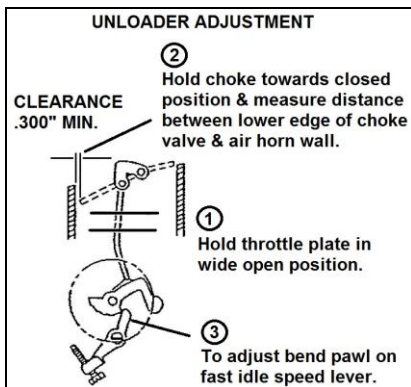
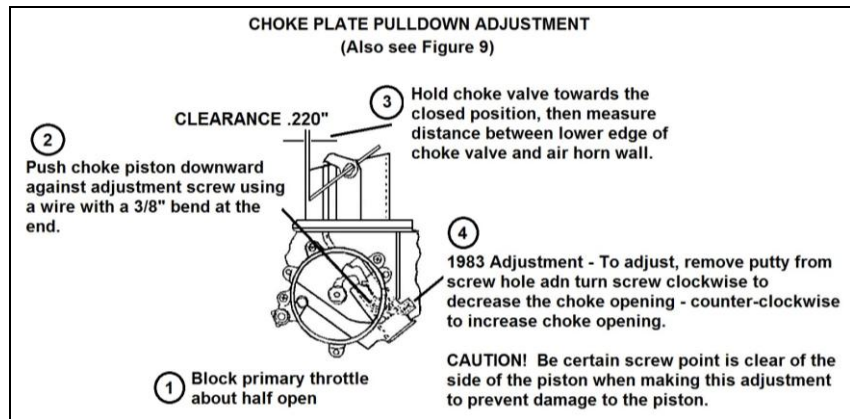
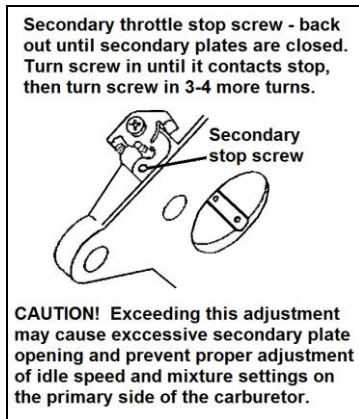
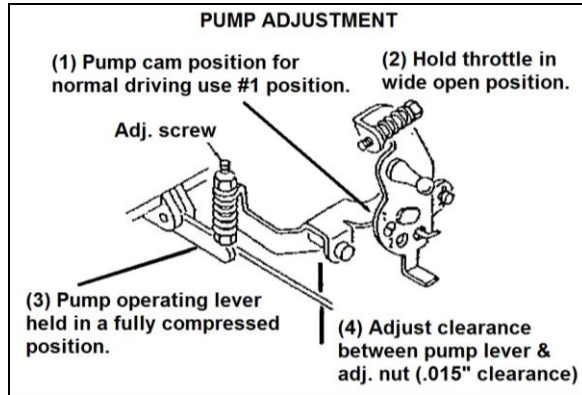
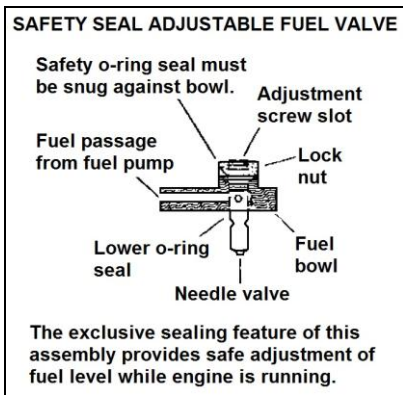
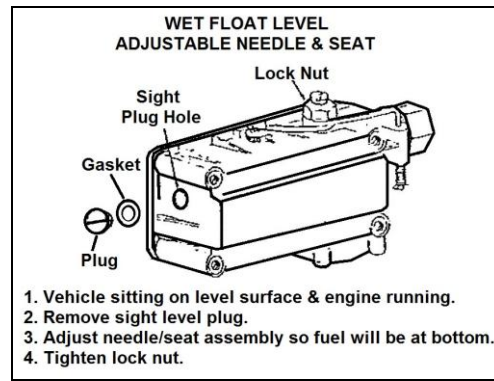
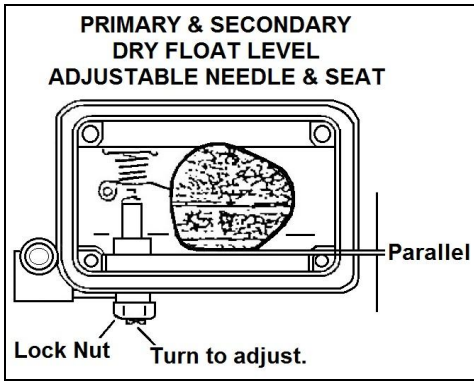

TAMPERPROOF IDLE MIXTURE SCREWS

To remove tamperproof idle mixture concealment plugs, center punch and drill 3/32" dia. hole through the hardened steel plug. Install an easy-out and remove the plug.

Before removing the idle adjusting screws, carefully turn the screws clockwise counting the number of turns it takes to lightly seat the screws. Record for proper re-assembly.

Reassembly - turn the idle mixture screws until lightly seated. Then, back out the number of turns recorded on disassembly.

Engine at operating temperature, refer to engine decal and car service manual for proper idle adjusting procedure and specifications. Replace plugs after completing adjustments.

CHOKE PLATE PULLDOWN ADJUSTMENT

CLEARANCE
 Carb # 1984
 E4TE-ARA - .185"
 E4ZE-SA - .206"

- Block primary throttle about half open.
- Push choke piston downward against adj. screw using a wire with a 1/8" bend at the end.
- Hold choke valve towards the closed position, then measure distance between lower edge of choke valve & air horn wall.
- 1984 adjustment: remove cup plug from screw hole. Turn screw clockwise to decrease the choke opening - counter-clockwise to increase the choke opening.

Plug

DIAPHRAGM TYPE CHOKE PLATE PULLDOWN ADJUSTMENT

- Open throttle and close choke valve, setting fast idle screw on high step of cam.
- Apply vacuum, source to passage in throttle body to completely seat diaphragm.
- Hold choke valve towards the closed position. Then, measure distance between lower edge of choke valve & air horn wall.
- To adjust - remove plug from screw hole & turn adj. screw on cover.

CARBURETOR TAB NUMBER	CLEARANCE
E4ZE-YA	.200"
E5HE-DA-DB-DC-DD-EA-EB-EC-ED	.170"
E5HE-FA	.150"
E5HE-LA-LB-LC-MA-MB-MC	.170"
E5TE-ZA-ZB	.157"
E5TE-ABA	.185"
E5ZE-GA	.175"
E5HE-AC	.140"
E5HE-GA-GB	.160"
E6JL-AA-AB-BA	.170"

©1987. Registered trademarks of Holley Performance Products

Holley
Performance Products Inc