



2-PIECE LS VALVE COVERS – PONTIAC STYLE, NO LOGO

241-190 – Natural Cast Finish

241-191 – Polished Finish

241-192 – Satin Black Finish

INSTRUCTION SHEET P/N 199R11960

PARTS LIST:

QUANTITY	DESCRIPTION
2	2-Piece LS Valve Cover Base, SBC Adaptable
2	2-Piece LS Pontiac Style OverCover
2	OverCover Gasket
8	OverCover Dress-Up Bolts – M5 x 0.8 Threads
2	Simulated Fill Cap for OverCover
4	Hardware for Simulated Fill Cap – 10-24 Threads
2	Low Profile Billet Oil Fill Cap w /O-ring
16	Gen I LS Coil Spacers
16	Gen V LS Coil Spacers
16	Coil Mounting Bolts - 1/4"-20 Thread, 1-1/4" Long
1	Warranty Sheet
1	Instruction Sheet

RECOMMENDED TOOLS FOR INSTALLATION:

3/8" Drive Ratchet	Torque Wrench	Flat Head Screwdrivers
10mm - 3/8" Drive Socket (for Coil Mounting Bolts)	5/16" - 3/8" Drive Socket (for Overcover Bolts)	8mm - 3/8" Drive Socket (for OE LS Valve Cover Bolts - Not Included)

APPLICATIONS:

Fits LS1, LS2, LS3, LS6, and LS7 engines. These valve covers feature integrated coil mounts that were designed specifically to fit Gen I and Gen V style LS coil bodies (OEM and some aftermarket).

GEN I STYLE LS COIL BODY INFO
Coils Not Included - Shown for Illustrative Purposes Only



Gen I Style LS Coil Body
Part Numbers:

GM: 12558948
MSD: 8262 / 82628, 82623 / 826283
AC Delco: D580

GEN V STYLE LS COIL BODY INFO
Coils Not Included - Shown for Illustrative Purposes Only



Gen V Style LS Coil Body
Part Numbers:

GM: 12570616
Holley: 410004
Accel: 140043 / 140043-8, 140043K / 140043K-8
MSD: 8265 / 82658, 82653 / 826583
AC Delco: D510C

OPTIONAL PARTS:

These valve covers do not include valve cover mounting bolts or corresponding rubber grommets. You may re-use your factory bolt assemblies, or other factory height hardware of your choice, though replacements may be necessary over time.

Purchasing new valve cover gaskets is recommended, but not required.

Carefully inspect all components that will be reused before installation to determine if a replacement part may be necessary.

LS Valve Cover Gaskets (Set of 2):
Mr. Gasket Part # 61040G

LS Valve Cover Bolt Grommets (Set of 8):
Fel-Pro® Part # ES72233

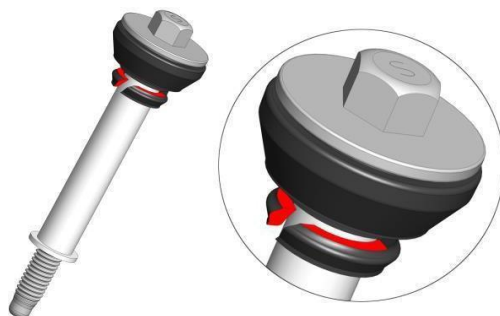

Figure 1 – Factory LS Valve Cover Hardware Assembly

NOTE: Aged grommets will likely tear during the removal and reinstallation processes. The area that is affected is only for temporary retention during installation and will not hurt the sealing function of the grommet.

INSTALLATION:

1. Before beginning, blow any loose debris off the engine using an air hose.
2. Disconnect the battery.
3. Remove any cosmetic engine/coil covers. Refer to the vehicle's service manual for proper removal procedure. If these covers mount to the original valve covers, they will not be reinstalled.
4. Disconnect the spark plug wire from each coil by twisting and pulling on each wire boot.
5. Disconnect the main coil harness plug as shown in **Figure 2** below.

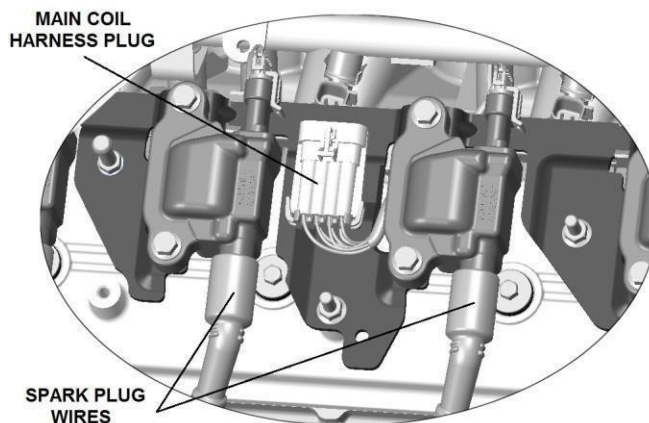

Figure 2

6. Remove the coils, coil brackets, coil harnesses, PCV hose, and existing valve covers from the vehicle.
7. Remove the original LS valve cover gaskets by gently pulling them out of the valve cover grooves.
8. Remove the valve cover retention bolt assemblies by carefully working the grommets out of the original valve covers. The original grommets are likely to have softened and swelled with age.

NOTE: If reusing the original grommets and gaskets, clean with only mild soap and hot water. Chemicals may damage the material and greatly affect their sealing ability.

9. Reinstall the gaskets by working them into the grooves in each Holley 2-piece LS valve cover base. The gaskets will be slightly long as compared to the grooves and will need to be evenly worked around the cover distributing the extra length. Press firmly to properly seat the gasket.
10. Reinstall the factory LS valve cover retention bolts by carefully working each hardware assembly (bolt, spacer, and grommet) into each valve cover base until the grommet is fully seated against the surface of each hole.
11. Install each Holley 2-piece LS valve cover base onto the engine, making sure the gasket remains seated in the valve cover groove and the bolts are making contact with the threads in the cylinder head. Evenly torque each valve cover retention bolt to **106 in/lb (9 ft/lb)**.

NOTE: The Holley 2-piece LS valve covers are designed to be used with rocker arms and lift ratios compatible with stock LS valve covers. If using aftermarket valve train components, refer to the manufacturer's instructions for compatibility.

12. Remove the corresponding rubber caps on the internally baffled ventilation tubes of your 2-piece LS valve cover bases and reconnect the PCV/ventilation hose(s).

NOTE: Some applications, as pictured below, have internal PCV restrictions inside the cover assembly. If your application utilizes this type of connection, an external PCV valve must be added in-line on the hose.

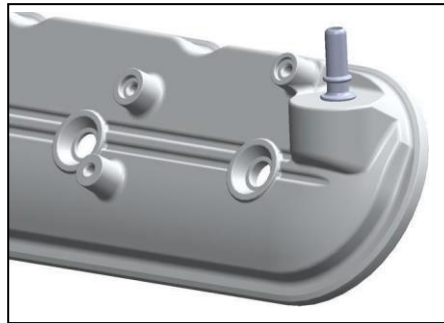

If required, a suggested PCV valve is: Beck/Arnley® P/N **143-0450299** or similar

13. If applicable, remove the exiting Gen I or Gen V coil bodies from the original brackets and install them onto the corresponding mounting posts on each Holley 2-piece LS valve cover base. Be sure to use the correct coil-specific spacers for your application and the included coil retention bolts. As shown in the diagram below, different mounting holes are used for Gen I and Gen V style LS coil bodies. Torque each coil retention bolt to **106 in/lb (9 ft/lb)**.

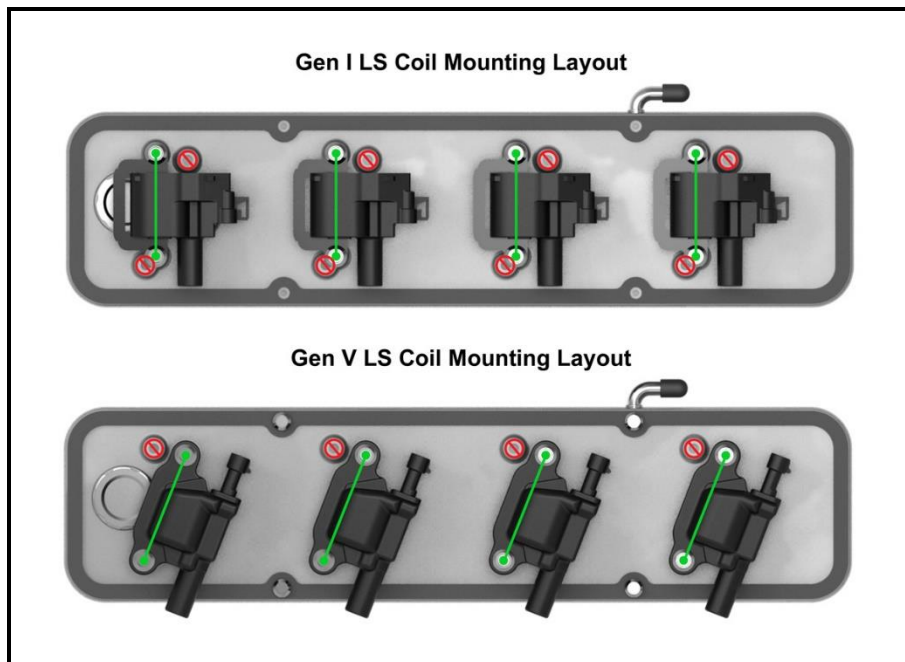

Figure 3

14. Remove the coil harnesses from the original brackets and plastic conduits. Reconnect the coil harnesses to the individual coils that were mounted onto each 2-piece LS valve cover base. Make sure the coil harnesses are not switched to the opposing sides and that each corresponds to the same coil that it was removed from - if harnesses are accidentally switched, the firing order will be wrong. Neatly tuck the wires around the mounted coils and route the main harness so that it will fit through the slot in the valley side of the overcover once installed.
15. Install the simulated fill caps onto each Pontiac-style overcover using the pre-threaded holes in each simulated fill cap and the included hardware. Each simulated fill cap should align over the two holes on top of each overcover and should be tightened for a secure fit using a screwdriver and the supplied 10-24 bolts.
16. Install the completed 2-piece LS Pontiac-style overcover using the supplied dress-up bolts and rubber grommets. When installing the overcover with Gen V LS coil bodies, first carefully slide the ends of the coils through the plug wire holes in the cover, and then rotate the cover lengthwise to route it around the coils and wiring harness. Be sure to check that the main coil harness clears the valley side exit hole and is not being pinched.
17. Reinstall the spark plug wires and rotate the boots for maximum exhaust clearance and visual appeal.
18. Make sure all electrical connections are secure and reconnect the battery.
19. Start the vehicle and verify that there are no oil leaks.

OIL FILL CAP INFO:

The low profile billet aluminum oil fill cap threads into each valve cover base and should be turned clockwise to install and counter-clockwise to remove.

NOTE: If using Gen I coil bodies, it will be necessary to unbolt and remove the coil located directly over the low profile fill cap in order to unscrew, remove, and fill the oil. It may be possible to leave that coil in place if using the angled Gen V coil bodies, but it is recommended to remove as well.

NOTE: Oiling the low profile billet fill cap's O-ring (**Figure 4**) will ease the cap removal/reinstallation process and is recommended.

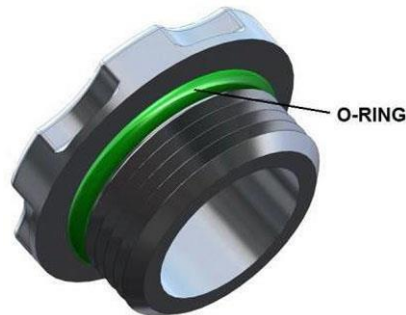

Figure 4