



## TALL LS “DOMINATOR” LOGO VALVE COVERS

241-118 – Natural Cast Finish  
241-119 – Polished Finish  
241-120 – Satin Black Machined Finish  
241-121 – Gloss Red Machined Finish

INSTRUCTION SHEET P/N 199R10941

### PARTS LIST:

QUANTITY	DESCRIPTION
1	Tall LS <i>Dominator</i> Valve Cover w/ Oil Fill (passenger’s side)
1	Tall LS <i>Dominator</i> Valve Cover (driver’s side)
1	Billet Oil Fill Cap w /O-ring (P/N 241-225)
8	Extended Hardware Assembly (bolt, spacer, & grommet)
1	Warranty Statement 90-day
1	Instruction Sheet

### APPLICATIONS:

Fits LS1, LS2, LS3, LS6, and LS7 engines. These valve covers do not have integrated coil mounts, therefore a coil relocation system will be required for proper usage.

### OPTIONAL PARTS:

Purchasing new valve cover gaskets is recommended, but not required. Valve cover bolt grommets are included in the factory-style extended hardware assemblies, but replacements may be necessary over time. These components can be purchased at your local parts supplier:

Gaskets (set of 2):  
*Fel-Pro®* part # **VS50504R**

Grommets (set of 8):  
*Fel-Pro®* part # **ES72233**

**BEFORE**

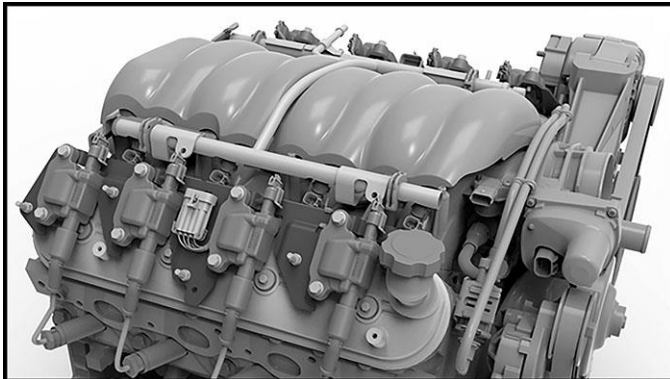

**AFTER**



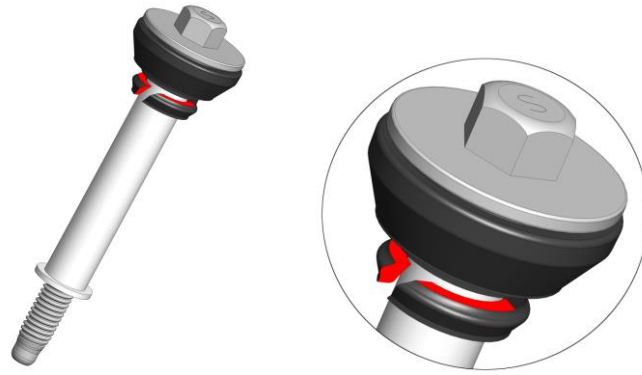
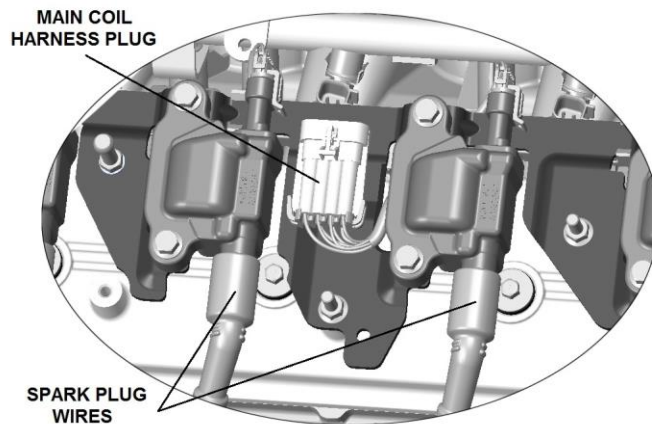

**Figure 1 – Factory LS Valve Cover Hardware Assembly**

**NOTE:** Aged grommets will likely tear during the removal and reinstallation processes. The area that is affected is only for temporary retention during installation and will not hurt the sealing function of the grommet.

**INSTALLATION:**

1. Before beginning, blow any loose debris off the engine using an air hose.
2. Disconnect the battery.
3. Remove any cosmetic engine/coil covers. Refer to the vehicle's service manual for proper removal procedure. If these covers mount to the original valve covers, they will not be reinstalled.
4. Disconnect the plug wire from each coil by twisting and pulling on each wire boot.
5. Disconnect the main coil harness plug.



**Figure 2**

6. Remove the coils, coil brackets, coil harnesses, PCV hose, and existing valve covers from the vehicle.
7. Remove the original gaskets by gently pulling them out of the valve cover grooves.
8. Remove the valve cover bolts and grommets by carefully working the grommets out of the original valve covers. The original grommets will have softened and swelled with age.

**NOTE:** If reusing the original grommets and gaskets, clean with only mild soap and hot water. Chemicals may damage the material and greatly affect their sealing ability.

9. Reinstall the gaskets by working them into the grooves on the Holley *Dominator* valve covers. The gaskets will be slightly long as compared to the grooves and will need to be evenly worked around the cover distributing the extra length. Press firmly to properly seat the gasket.

10. Reinstall the bolts and grommets by carefully working them into the Holley *Dominator* valve covers.
  11. Install the Holley *Dominator* valve covers on the engine making sure the gasket remains seated in the valve cover groove. Evenly torque the cover bolts to **12 Nm (106 lb/in)**.
- NOTE:** The Holley *Dominator* valve covers are designed to be used with rocker arms and lift ratios compatible with stock valve covers. If using aftermarket valve train components, refer to the manufacturer's instructions for compatibility.
12. Remove the corresponding rubber cap on the Holley *Dominator* valve cover and reconnect the PCV hose.
- NOTE:** Some applications, as pictured below, have internal PCV restrictions inside the cover assembly. If your application utilizes this type of connection, an external PCV valve must be added in-line on the hose. If needed, suggested PCV valves are: (1) Beck/Arnley® P/N **0450299** or (2) Fram® P/N **FV340**.

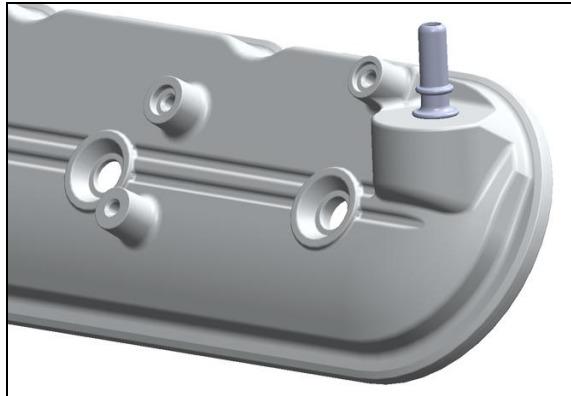

13. Remove the individual coils from the original bracket and install them into your chosen relocation brackets. Torque the coil bolts to **12 Nm (106 lb/in)**.
14. Remove the coil harnesses from the original brackets and plastic conduits. Reconnect the coil harnesses to the coils. Make sure the coil harnesses are not switched to the opposing sides. If harnesses are accidentally switched, the firing order will be wrong. Neatly tuck the harnesses into the engine valley and retain with wire ties.
15. Reinstall the spark plug wires and rotate the boots for maximum exhaust clearance and visual appeal.
16. Make sure all electrical connections are secure and reconnect the battery.
17. Start the vehicle and verify that there are no oil leaks.

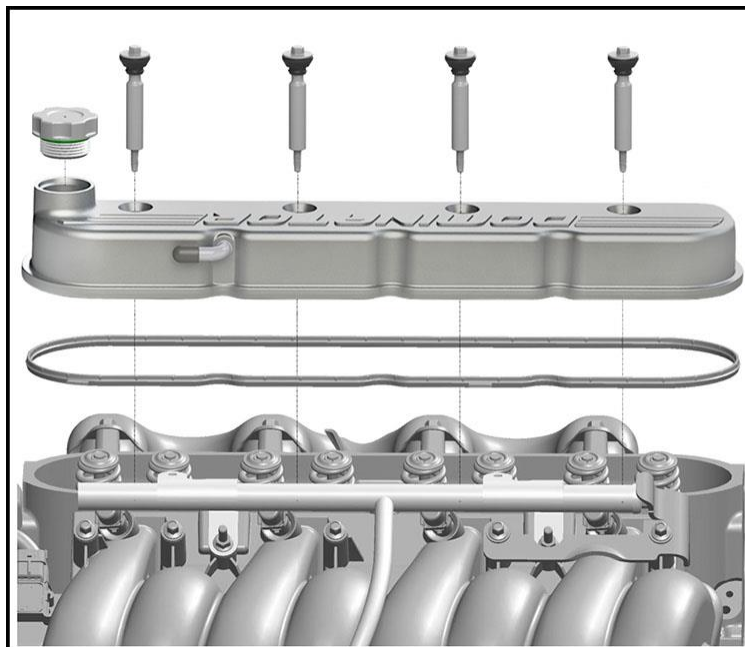
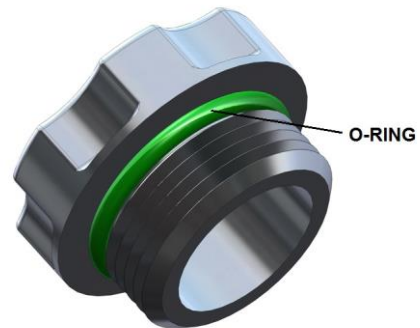

**Figure 3**

## OIL FILL CAP:

The billet cap threads into the valve cover and should be turned clockwise to install and counter-clockwise to remove.

**NOTE:** Oiling the billet fill cap's O-ring (**Figure 4**) will ease the cap removal/reinstallation process and is recommended.



**Figure 4**

**NOTE:** If the oil fill cap is ever damaged or lost, a replacement cap is available under **P/N 241-225**.