

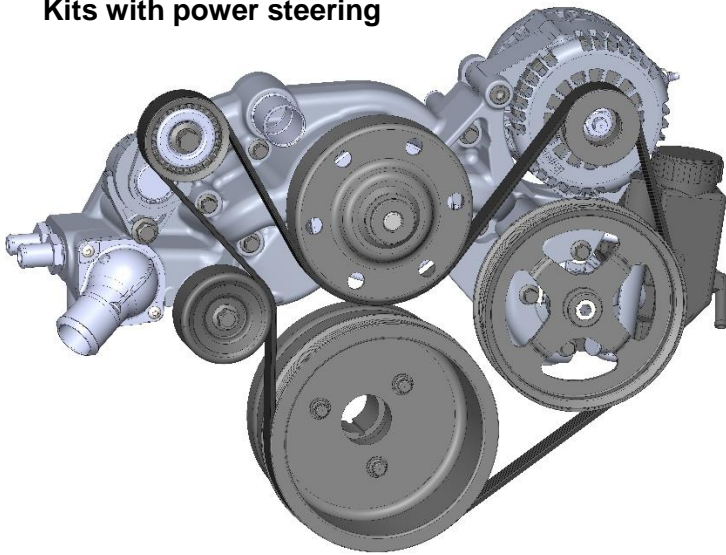

Complete Holley Mid-Mount Accessory Drive Kit

Part Numbers: 20-181, 20-181BK, 20-181P, 20-182, 20-182BK, 20-182P, 20-191, 20-191BK, 20-191P, 20-192, 20-192BK, 20-192P, 20-201, 20-201BK, 20-201P, 20-202, 20-202BK, 20-202P, 20-186, 20-186BK, 20-186P, 20-187, 20-187BK, and 20-187P

Kits with power steering



Kits without power steering

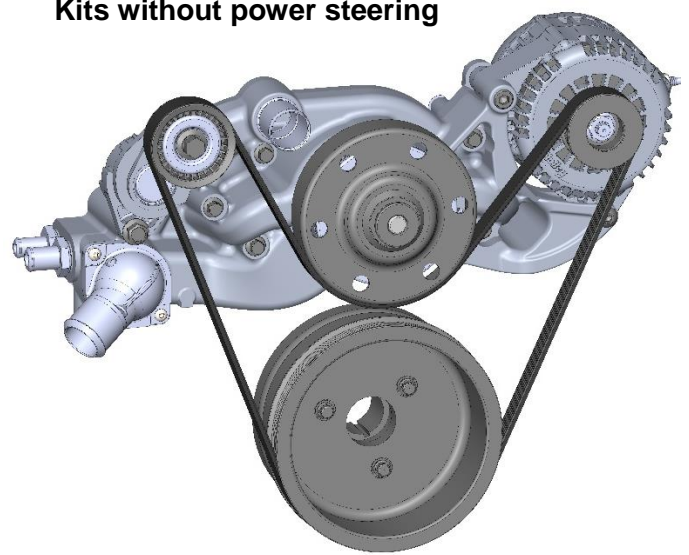









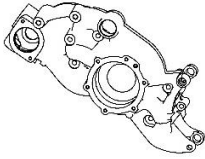

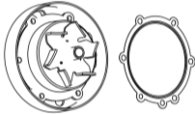

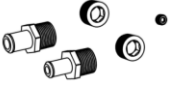
Holley's Mid-Mount complete accessory system has all accessories pulled in tighter than other accessory drives. Among the many swap friendly features is the bracket-less assembly that actually mounts all accessories to the water pump directly.

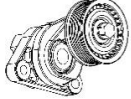

Features:

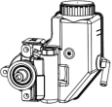
- Bracket-less accessory mounting with ultra-easy assembly
- Bottom outlet heater hose options for swap application clearance
- LT1 style hairpin premium alternator
- LT1 style water pump design
- Type II power steering pump with baffled reservoir (does not apply to 20-182, 20-182BK, 20-182P, 20-192, 20-192BK, 20-192P, 20-202, 20-202BK, 20-202P, 20-187, 20-187BK, and 20-187P)
- OE pulley ratios for optimal accessory performance
- Available for LS and LT applications
- Billet alternator pulley covers (does not apply to 20-186, 20-186BK, 20-186P, 20-187, 20-187BK, and 20-187P)
- SFI certified damper w/hard anodized billet crank pulley (does not apply to 20-186, 20-186BK, 20-186P, 20-187, 20-187BK, and 20-187P)

Parts List:

PICTURE	QTY	DESCRIPTION	REPLACEMENT MANUFACTURER & P/N
	1	Manifold Assembly, Water Pump	With P/S: Holley 97-222 (LS natural) / 97-224 (LS black) / 97-226 (LS polished) 97-223 (LT natural) / 97-225 (LT black) / 97-229 (LT polished) Without P/S: Holley 97-231 (LS natural) / 97-233 (LS black) / 97-235 (LS polished) 97-232 (LT natural) / 97-234 (LT black) / 97-236 (LT polished)
	1	Gaskets, Water Pump	GM 12630223 (LS) / 12657430 (LT)
	1	Water Pump Drive Assembly / Gasket	Pump Holley 97-200 / Gasket GM 12619770
	1	Belt, 6 Rib Serpentine	With P/S: BANDO 6PK1380 Without P/S: BANDO 6PK1320
	1	Thermostat 180° / housing	Holley 97-169 (set) GM 89018168 (thermostat only)
	1	NPT Adapters (2) & Plugs (3)	Holley 97-177
	1	Alternator / harness pigtail	Holley 197-302 (natural) / 197-303 (black) / 197-304 (polished), Pigtail Holley 197-400
	1	Tensioner Assembly with Grooved Pulley	Holley 97-151 OR Gates 38194
	1	Damper Crank Bolt (OE)	GM 12557840 (LS1, 2, 3, 6, & LT) / 11570163 (LS7)

Included Only With: 20-181, 20-181BK, 20-181P, 20-191, 20-191BK, 20-191P, 20-201, 20-201BK, 20-201P, 20-186, 20-186BK, and 20-186P			
	1	P/S Pump with Reservoir	Holley P/N 198-101
	1	P/S Pressure Hardline to -6 AN, Banjo Bolt, crush washers (2), & Hardware	Holley 198-203
	1	P/S Pulley	Holley P/N 97-152
	1	Idler Pulley	Holley P/N 97-150 / Dayco P/N 89059

HARDWARE (REPLACEMENT with P/S 97-220, without PS 97-221)		HARDWARE APPLICATION	
	1	Button Head Bolt, M10 X 1.5 X 80	Alternator (outside)
	2	Button Head Cap Bolt, M6 X 1.0 X 18	Thermostat Housing
	6	Button Head Bolt, M6 X 1.0 X 20	Water Pump to Manifold
	1	Socket Head Cap Bolt, M10 X 1.5 X 75	Alternator (inside)
	5	Flange Head Bolt, M8 X 1.25 X 115	Manifold to Engine Block
	1	Flange Head Bolt, M8 X 1.25 X 50	Manifold to Engine Block
	2	Flange Head Bolt, M10 X 1.5 X 35	Tensioner
	1	Flange Head Bolt, M10 X 1.5 X 35	Idler (only on kits with P/S)
	3	Flange Head Bolt, M8 X 1.25 X 30	P/S Pump (only on kits with P/S)

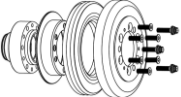
Included Only With: 20-181, 20-181BK, 20-181P, 20-182, 20-182BK, 20-182P, 20-191, 20-191BK, 20-191P, 20-192, 20-192BK, 20-192P, 20-201, 20-201BK, 20-201P, 20-202, 20-202BK, and 20-202P			
	1	Crank Pulley	Holley 97-159 (LS1, 2, 3, & 6) / 97-160 (LS7) / 97-161 (LT)
	1	Hub, Inner Shell, Damper assembly, Outer Shell, & Hardware (crank pulley bolts included with this hardware).	Holley 97-190 (LS1, 2, 3, & 6) / 97-191 (LS7) / 97-192 (LT)

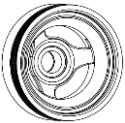
Included Only With: 20-186, 20-186BK, 20-186P, 20-187, 20-187BK, and 20-187P			
	1	One-piece damper / pulley	Holley 97-205

Included Only With: 20-181, 20-181BK, 20-181P, 20-182, 20-182BK, 20-182P, 20-191, 20-191BK, 20-191P, 20-192, 20-192BK, 20-192P, 20-201, 20-201BK, 20-201P, 20-202, 20-202BK, and 20-202P			
	1	Alternator Pulley Cover & O-ring	Holley 97-187 (black) / 97-188 (polished)

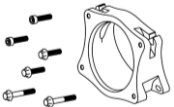
Included Only With: 20-201, 20-201BK, 20-201P, 20-202, 20-202BK, and 20-202P,			
	1	Throttle Body Angle Adapter & Hardware	Holley 717-15

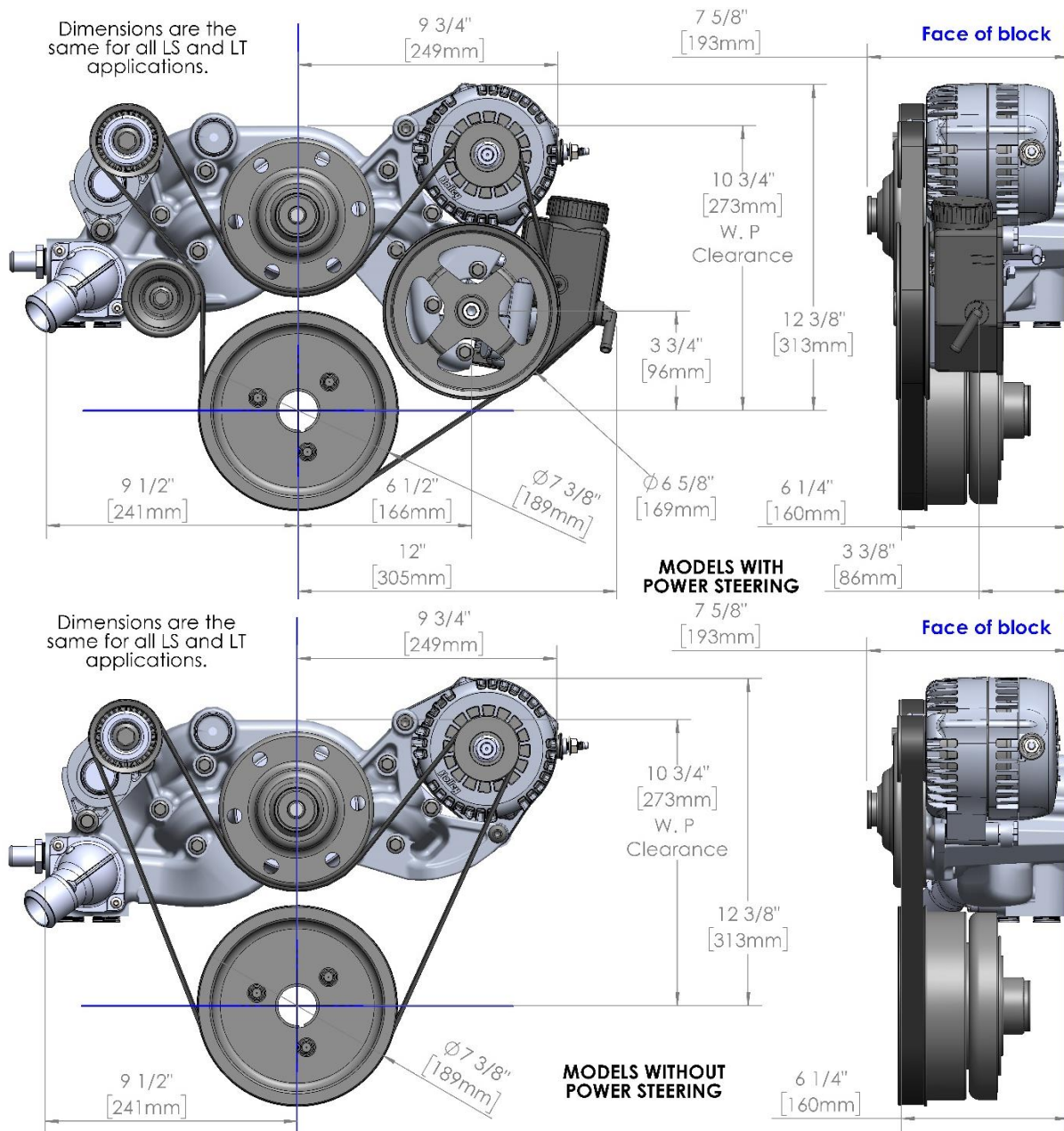

IMPORTANT NOTE IF PAINTING COMPONENTS: The alternator and A/C compressor ground through the water pump manifold. If painting or coating the manifold, the mating surfaces must all be bare metal allowing a ground path from the accessories' mounting feet to the engine block and ultimately the negative terminal on the battery.

Assembly Instructions

HELPFUL HINT: The below assembly order is optimized for explanation and the average application. It may be easier to preassemble some components to the manifold before mounting to the engine. Torqueing of the components may however be easier after mounting. The only component that cannot be preassembled is the tensioner, as it would prevent access to a mounting bolt. Keep in mind adding components increases overall size and weight and may require an additional person when mounting.

Steam Vent Inlet Port (optional):

A port is provided for convenient and simple routing of LS steam venting. If not utilizing the steam inlet port, install the 1/8" NPT plug provided. Use thread sealant (Loctite® brand 567 pipe thread sealant or equivalent). Install to finger tight, and then tighten 2 to 3 rounds.

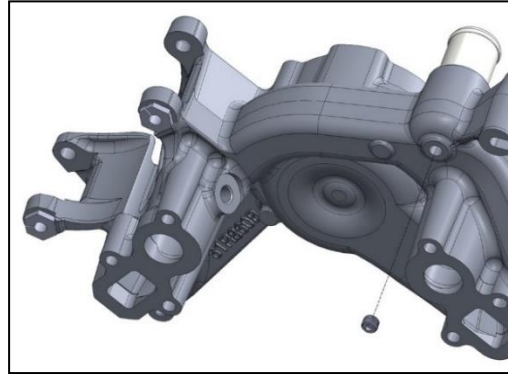

Suggested accessories (not included): Holley 26-552 complete LS steam tube plumbing kit

ECU Water Temperature Sensor Installation (LT applications only):

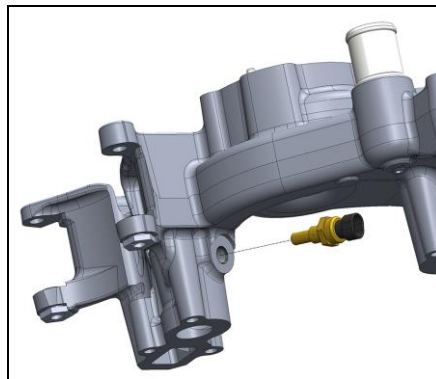

Install original temperature sensor removed from the LT water pump manifold. Torque to 15 ft/lb.

Water Pump and Gasket Installation:

Helpful Hint: Do not confuse these M6 X 20 long bolts with the two M6 X 18 bolts to be used later.

NOTE: Torque M6 button head bolts to 85 in/lbs. Use a standard 4mm hex tool. Do not use a ball hex tool. **Do not overtighten.**

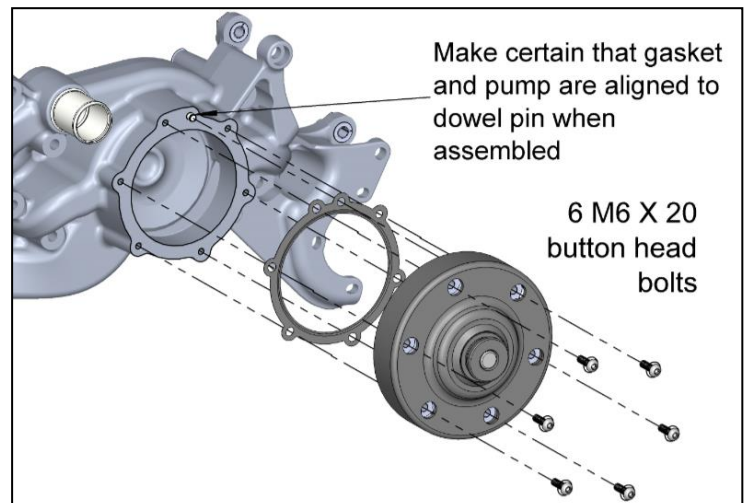

Damper / Crank Pulley Assembly Installation (whichever applies to your Kit):

SFI certified damper and billet pulley

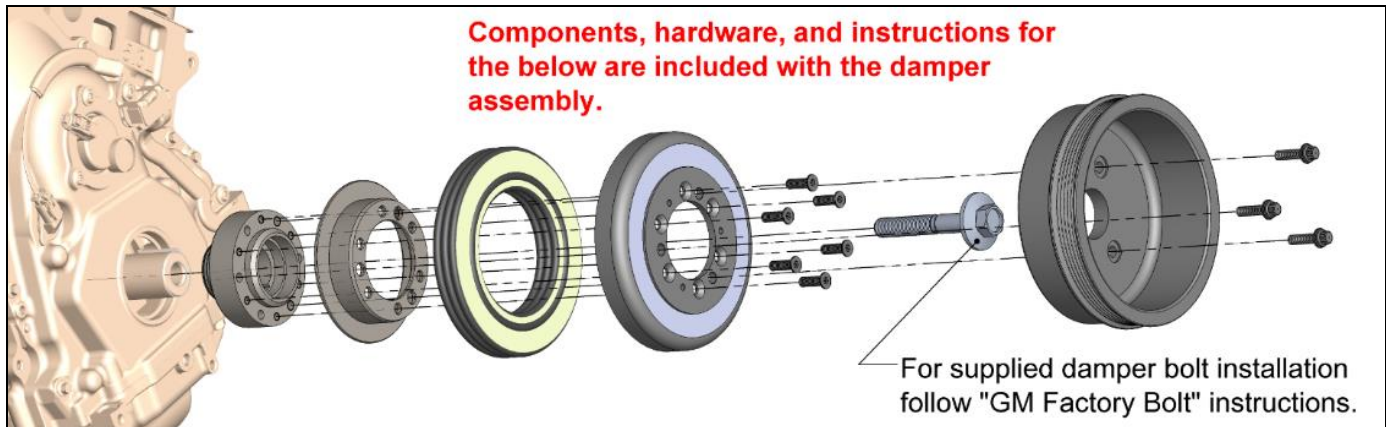

HELPFUL HINT: The above parts have a tight slip fit if aligned perfectly before assembly. If the aluminum pulley does not slip in the hub bore, the pulley can be placed in a freezer for 3 hours minimum. Remove and immediately install. Make certain the three pulley holes align to the hub while frozen because after the pulley warms you will likely not be able to rotate it in the hub.

One-piece OE style damper/pulley

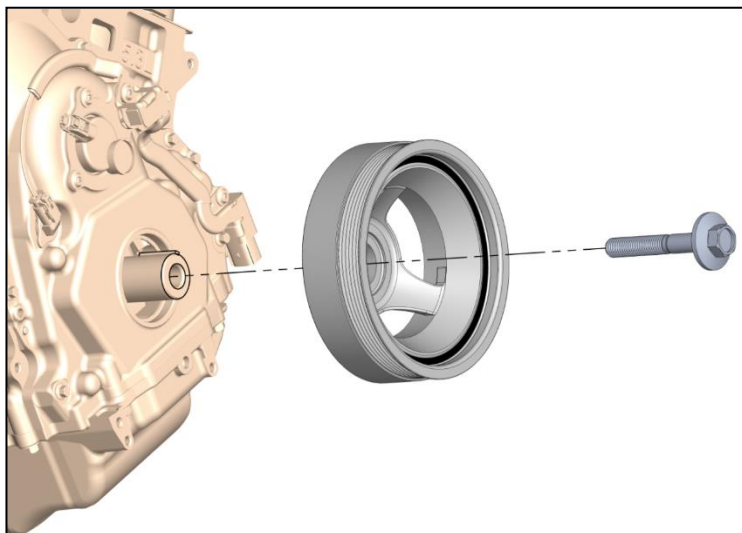

1. Remove original bolt (retain this bolt for later use)
2. Remove existing damper/pulley with an LS style puller like ICT P/N 551329.
3. Apply lubricate to the bore of the new damper hub and to the hub side of the original bolt head
4. Use an installation tool like ICT 551141 to install the new damper/pulley. Remove tool.

5. Install the original bolt and torque to 240 ft./lbs. to seat and then remove the bolt. During torqueing, use a flywheel holder like Trick Flow TFS-90326 to prevent the engine from turning.
6. Install and tighten the new (unused) bolt to 59 ft./lbs.
7. At this time, reference the front of the engine with the handle of the wrench. Mark with tape where 125° of clockwise rotation would be from where 59 ft./lbs. was obtained.
8. Rotate the wrench / bolt 125°. Remove the flywheel holder tool. The installation process is now complete

Note: Only use a new (unused) bolt for the last steps.

Manifold Installation:

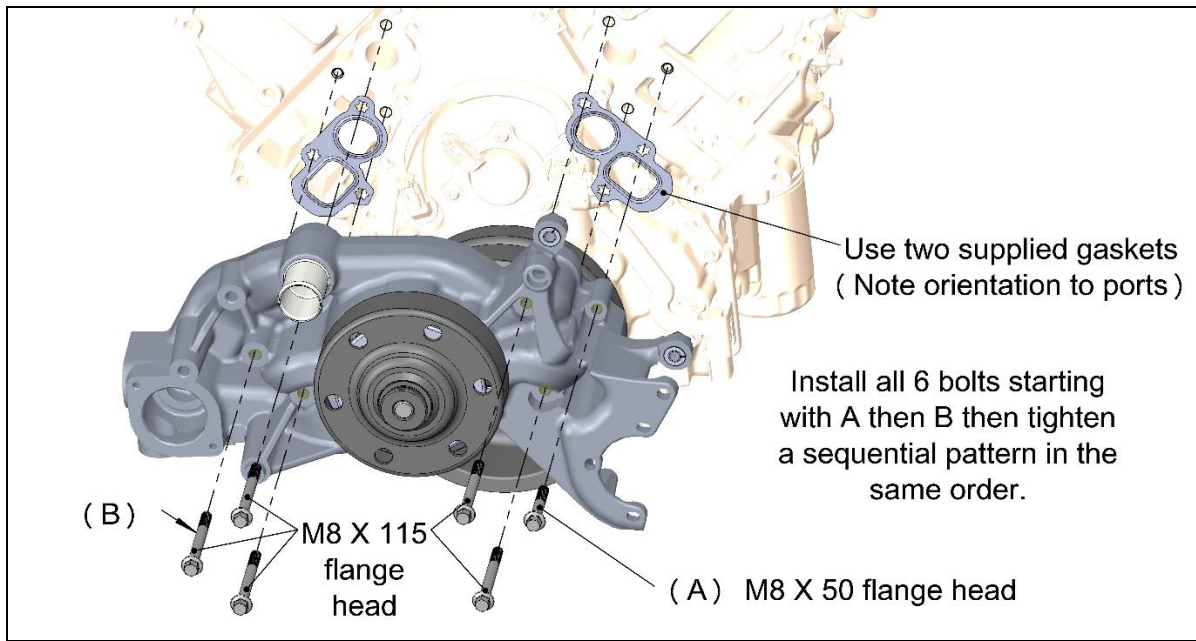

NOTE: Torque M8 bolts to 18 ft./lbs.

Thermostat and Heater Hose Adapter Installation:

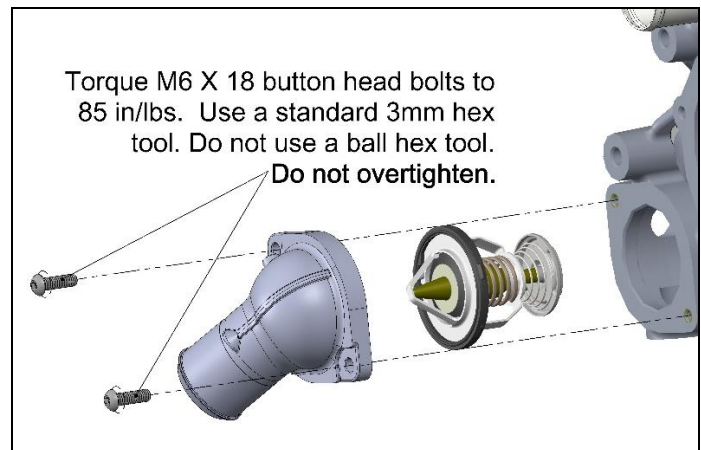
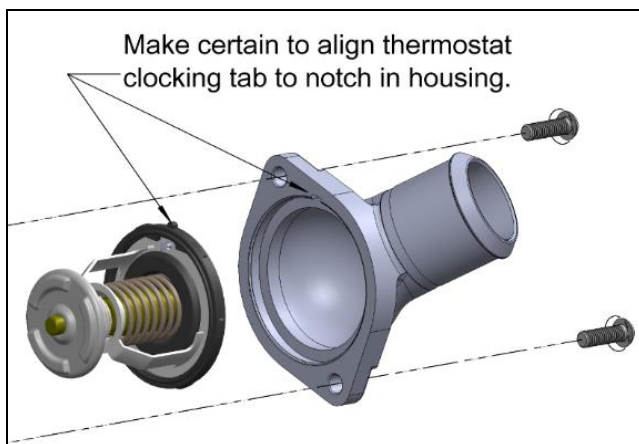

WARNING: Do not plug all heater passages. For safe LS/LT engine start up cooling this path must stay open. If not utilizing a heater core, install a jumper hose between the two barbs.

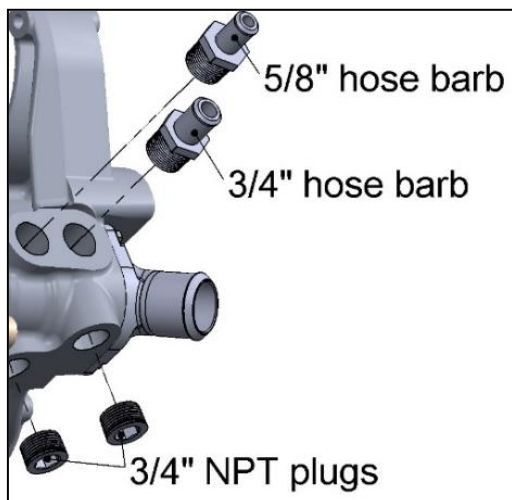

Configurations: On some swap applications there is not clearance for side heater hose outlets. There are optional bottom outlets for these applications.





Assembly: Install the smaller 5/8" barb on either the rear side or rear bottom port first, then the large 3/4" barb on either front port. Plug the unused ports.

Use thread sealant (Loctite® brand 567 pipe thread sealant or equivalent). Install to finger tight then tighten 2 to 3 rounds.

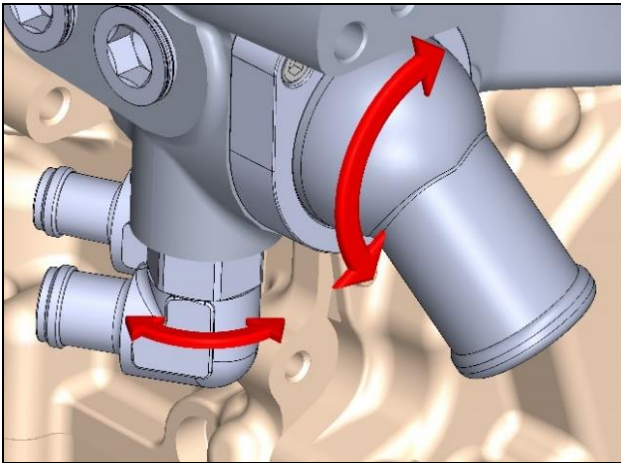
Alternate Installation Option (additional parts required):

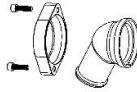
For applications with interference on the passenger side, the shown swivel adapters are available (not included).



PICTURE	DESCRIPTION	MANUFACTURER & P/N
	Swivel Thermostat Housing	Mr. Gasket 2670 (chrome) 2670BK (black) 2670NA (natural)
	Early Style Thermostat (required for above)	Mr. Gasket 6368
	Swivel 90° 3/4" Barb 3/4" NPT	Earl's SS988412ERL
	Swivel 90° 5/8" Barb to 3/4" NPT	Earl's SS988409ERL

Alternator Installation:

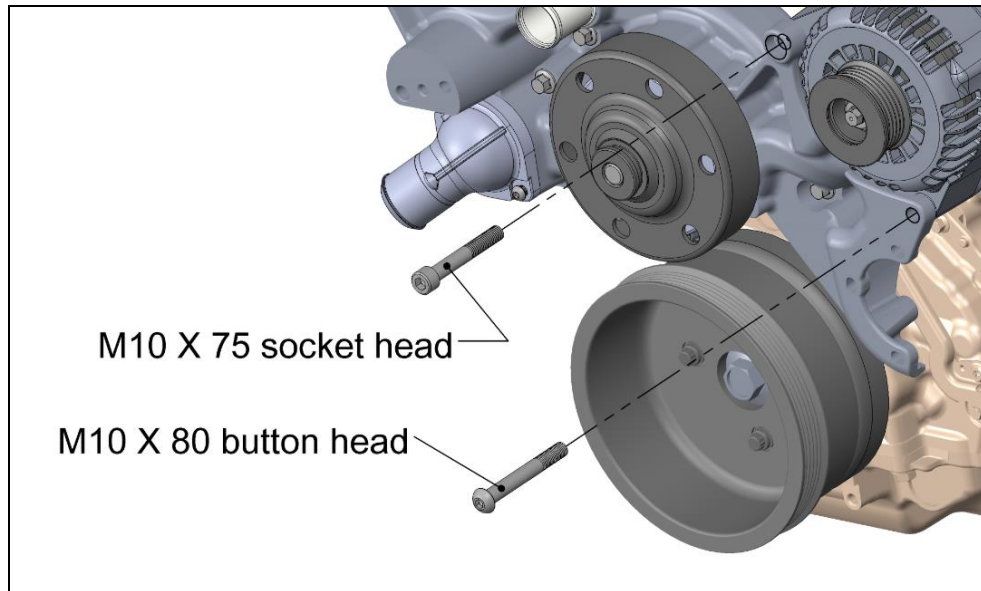

NOTE: Torque M10 bolts to 36 ft./lbs.

ALTERNATOR WIRING: See instructions included with the alternator for wiring directions.

P/S Pump -6 AN Adapter Assembly (only applies to kits with power steering):

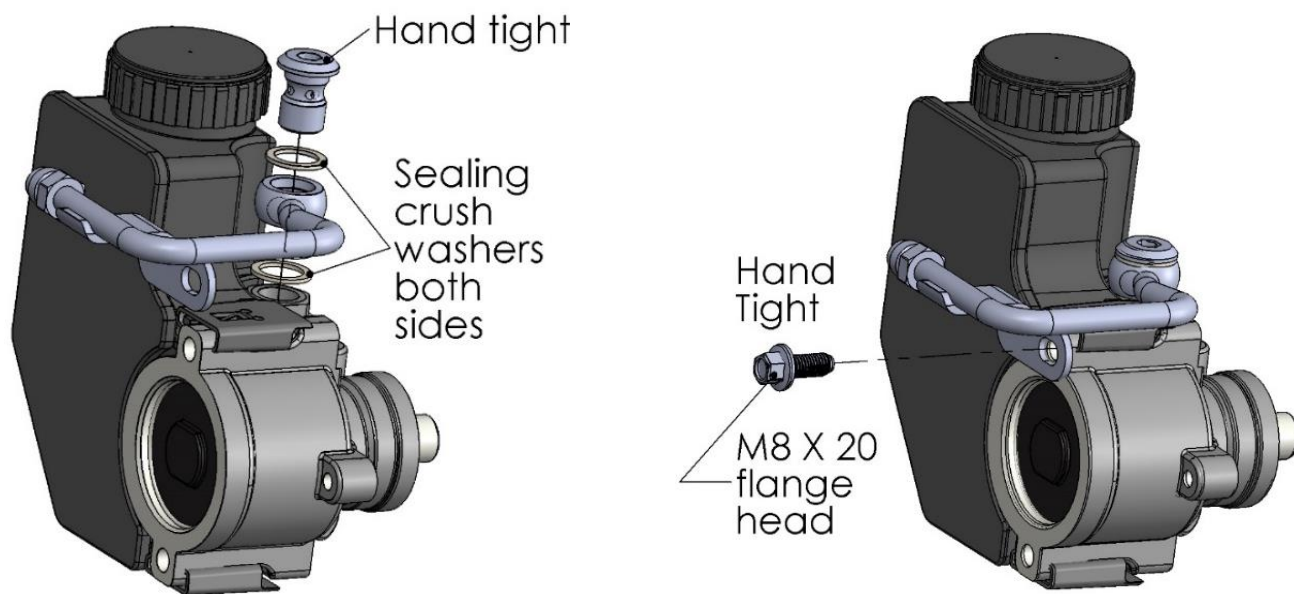

NOTE: After assembly torque M8 bolts to 18 ft./lbs. and banjo bolt to 25 ft./lbs.

P/S Pump Pulley Installation:

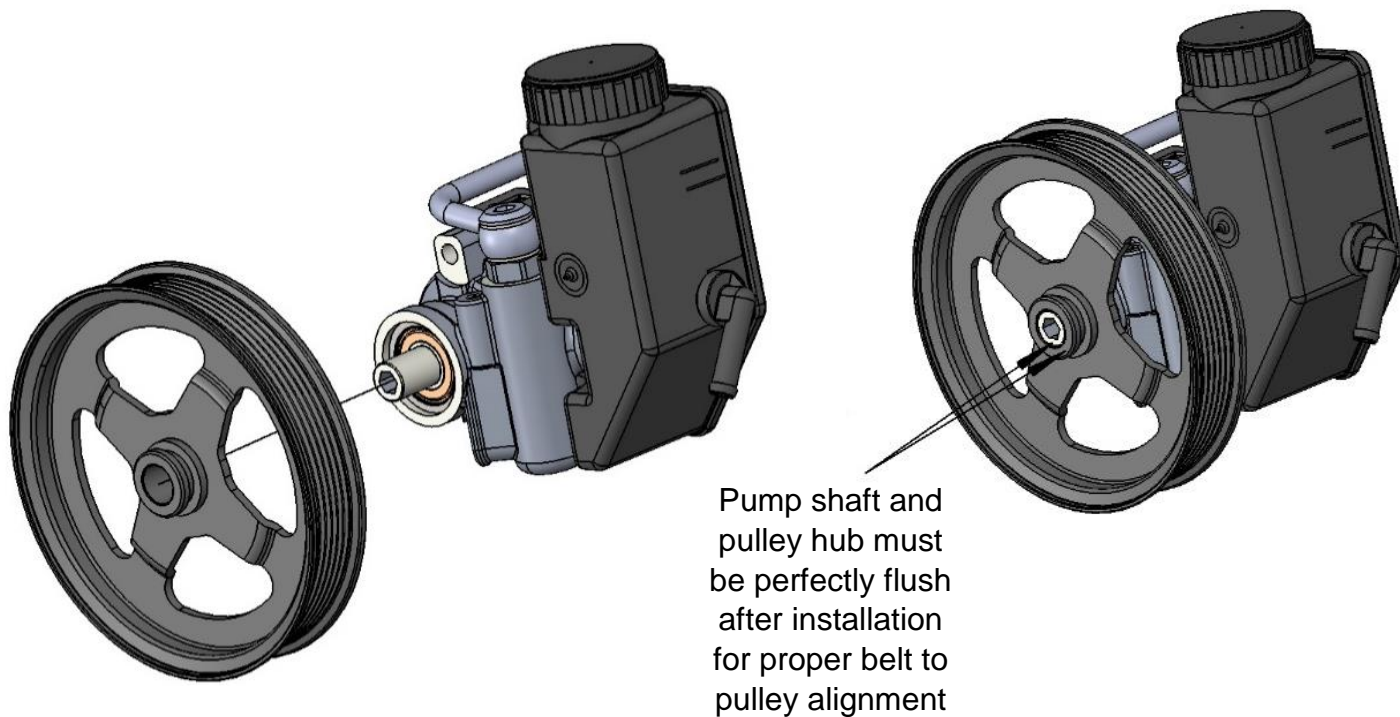

HELPFUL HINT: Pulley installation tools are available for rent at most auto parts stores.

P/S Assembly Installation (only applies to kits with power steering):

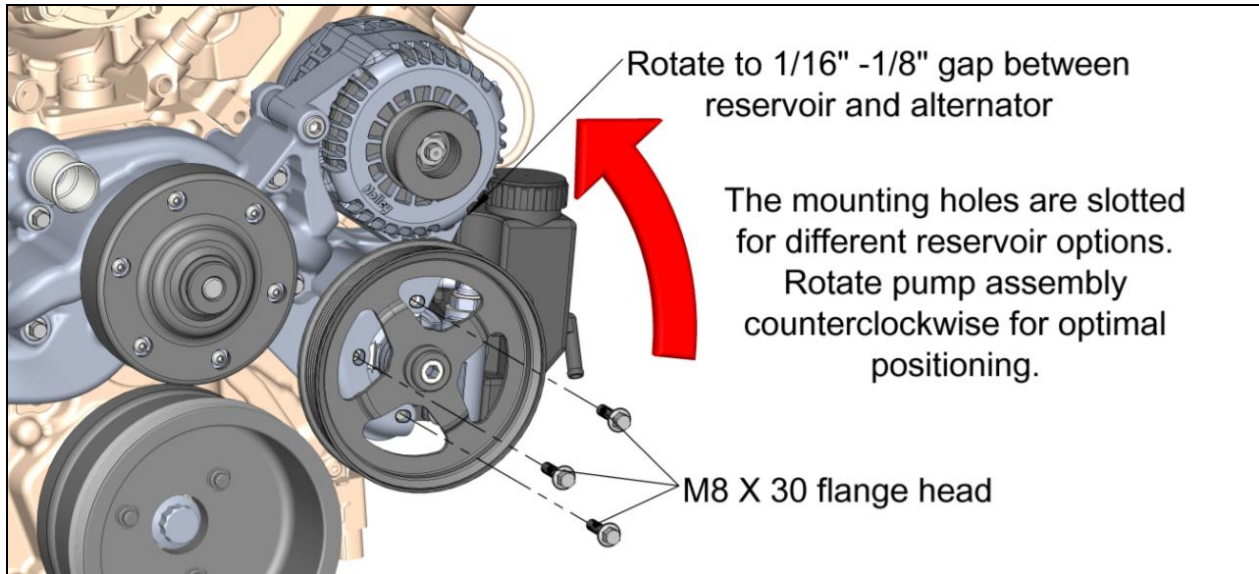

NOTE: Torque M8 bolts to 18 ft./lbs.

HELPFUL HINT: In some applications, the supplied reservoir may interfere with the vehicle. In these cases, a remote reservoir can be utilized. Holley P/S pump P/N 198-100 is best suited for use with remote reservoirs. Also, check the Holley website for additional reservoir alternatives.

Tensioner Installation:

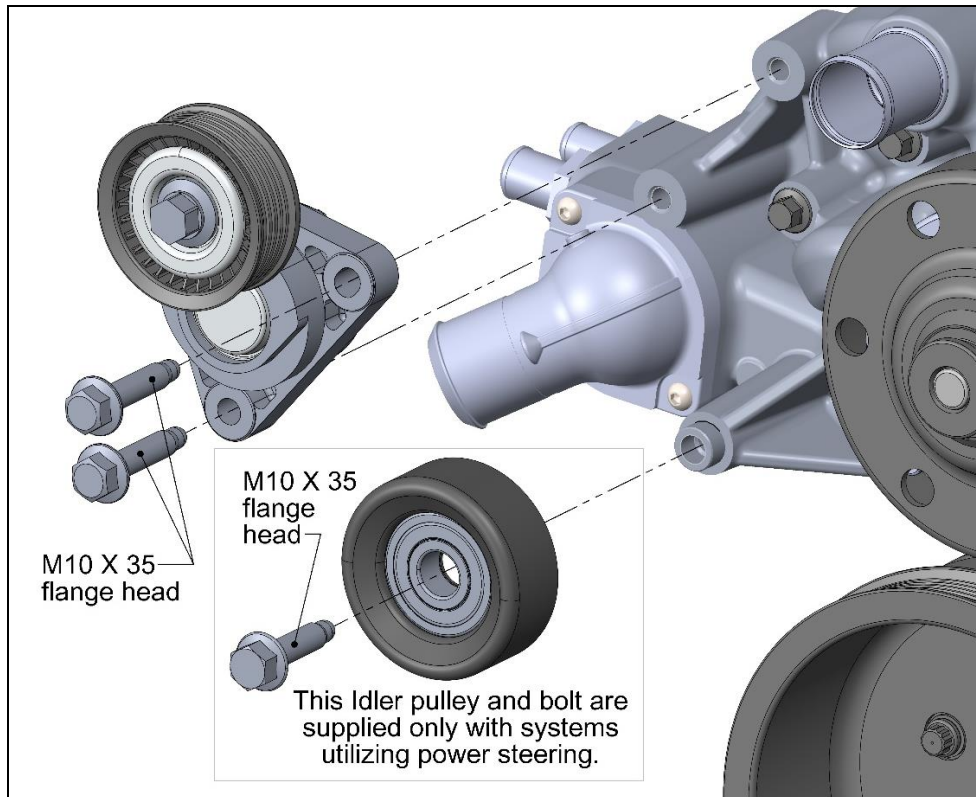

NOTE: Torque M10 bolts to 36 ft./lbs.

Belt Installation:

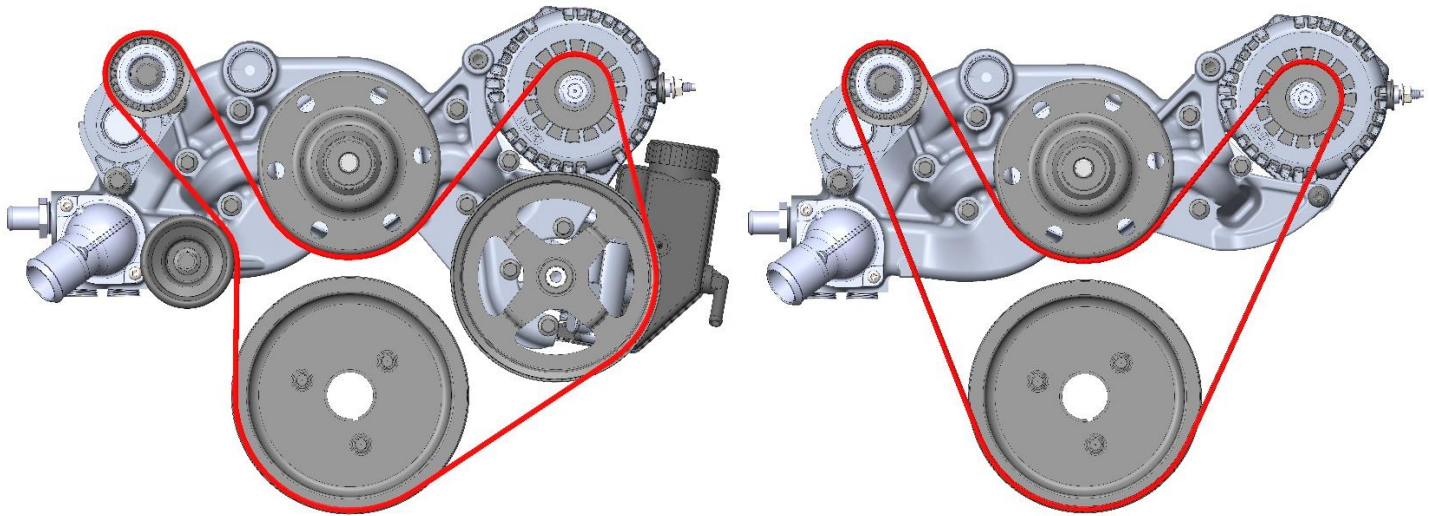

Route belt around pulleys as shown in red.

For easy installation route onto all grooved pulleys first and then onto the smooth water pump pulley.

Accessory and tensioner covers:

(A cosmetic alternator pulley cover is included with some kits. If not included, these can be purchased individually. See instructions included with cover for installation procedures)

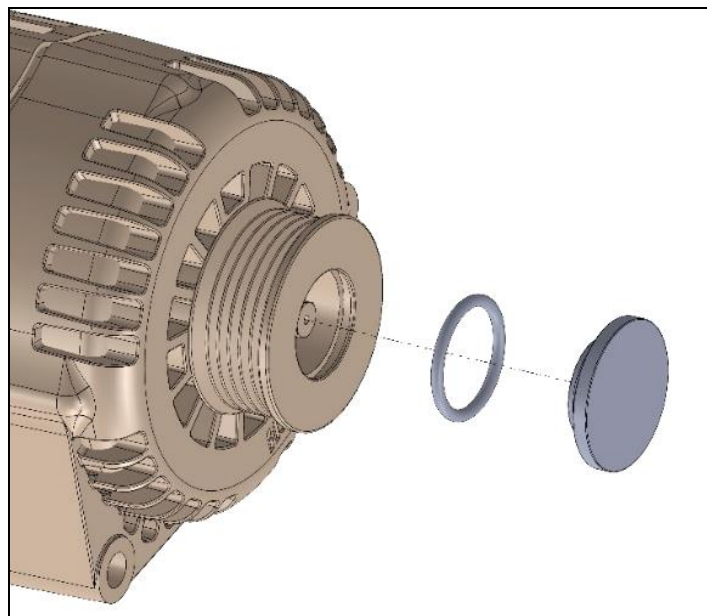

Throttle Body Angle Correcting Adapter (LT applications only):

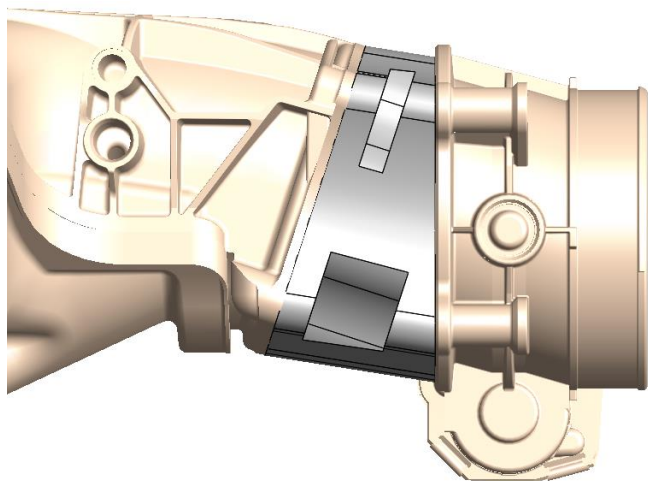

NOTE: The angle adapter is required when using an LT car style intake to prevent interference from the downward facing throttle body. See included instructions for installation procedures.