



Holley A/C Bracket System Part Number 20-141

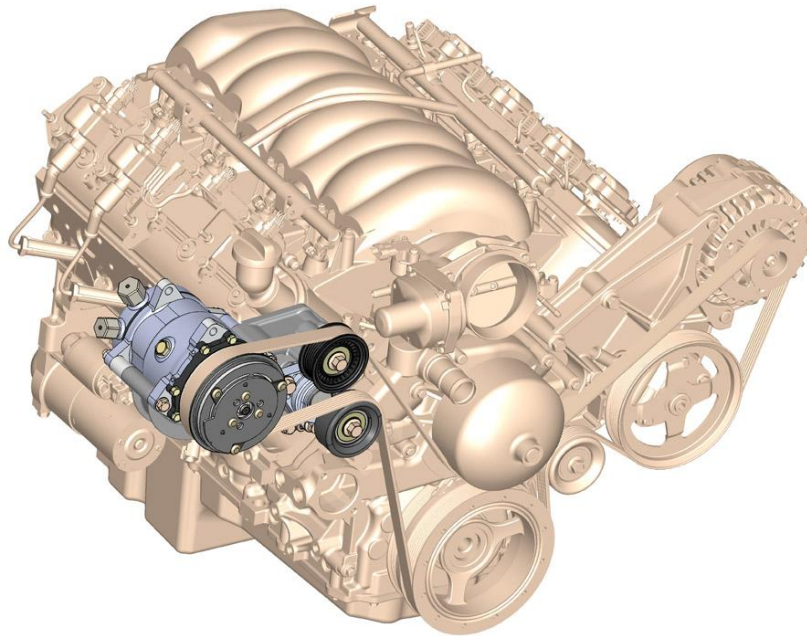
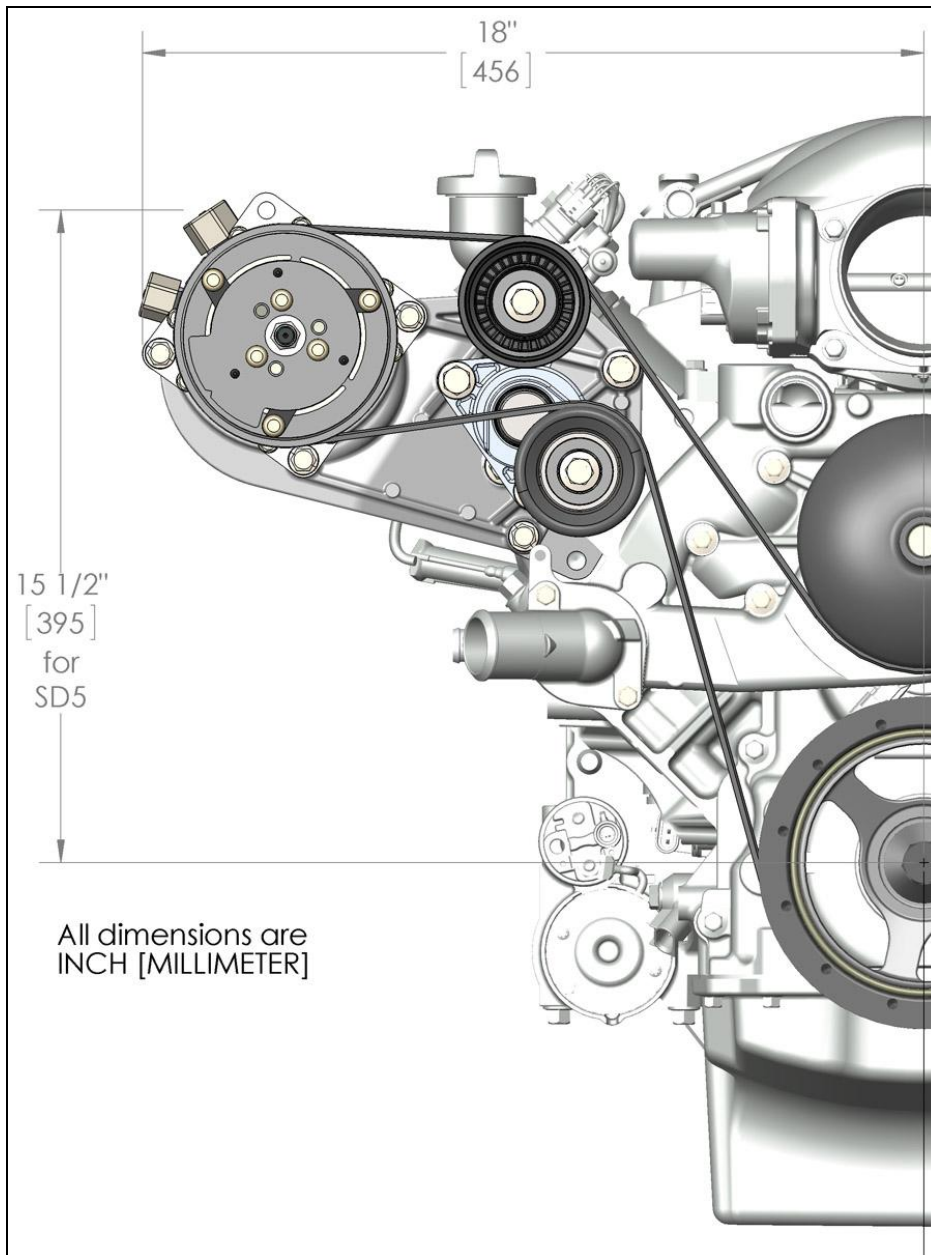

Table of Contents:

Introduction:.....	2
Crank Pulley Belt Alignment Determination:.....	3
Overview of Parts Required (but NOT included with 20-141 accessory drive system):	3
Water Pump Determination:.....	4
Parts List:	7
Assembly Instructions	8
Passenger's Side Bracket Installation:.....	8
Idler & Tensioner Installation:	9
A/C Compressor Installation:	10
Belt Routing:	11
Warranty Information.....	12



Introduction:

Holley's accessory drive systems offer clean, economical brackets and accessories for LS engines. These accessory drives look truly at home on any LS engine as if they came from the factory this way.

Holley's complete A/C bracket systems come with virtually everything needed for installation, from the A/C compressor to the pulleys. Most LS driver's side brackets and components can be used with this kit.

The first step is to determine which belt alignment you want to proceed with. This is determined by the crank pulley and often, but not always, the water pump. If clearance to the radiator is an issue, the compact STANDARD spacing common on the Corvette may be preferred. Otherwise, it is most cost effective to retain the existing crank pulley/water pump and space the bracket and other accessories to match. **An application specific installation kit (part # 21-1, 21-2, or 21-3) is REQUIRED for this accessory drive system.**

Crank Pulley Belt Alignment Determination:

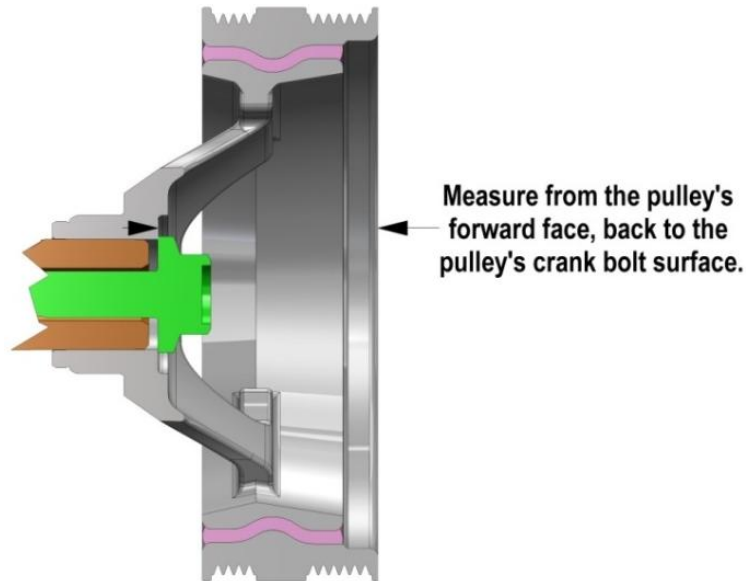

See the below chart for reference dimensions.

Overview of Parts Required (but NOT included with 20-141 accessory drive system):

Components with specific belt alignments

Belt Alignment Group	LS Application (Alignment Specific)	Holley Installation Kit (Alignment Specific)	Crank Pulley (Reference Dimension)		Water Pump (Alignment Specific)	Original Equipment Driver's Side Bracket
					GM #	GM # (Numerous)
Standard	Corvette / CTS-V / G8	21-1	1.5"	37 MM	19256263, 89018052, or 12604630	Most LS driver's side brackets and components can be used with this kit, but only in conjunction with the corresponding alignment's installation kit (21-1, 21-2, or 21-3)
Middle	F-body / GTO	21-2	2.25"	55 MM	19256263	
Long	Camaro ('10-UP) / Truck (all)	21-3	3"	75 MM	19207665 or any truck WP	

Water Pump Determination:

To determine which water pump type you have, refer to the following illustrations:

LS1/LS2/LS6 wide pulley water pump
Works with **STANDARD** and **MIDDLE** belt spacings

GM P/N 19256263
'97-'04 Corvette
'04-'05 CTS-V
'98-'02 Camaro/Firebird
'04-'06 GTO

This round boss may not be present on this water pump

Identifying feature:
Wide pulley allowing for both standard and middle belt spacings

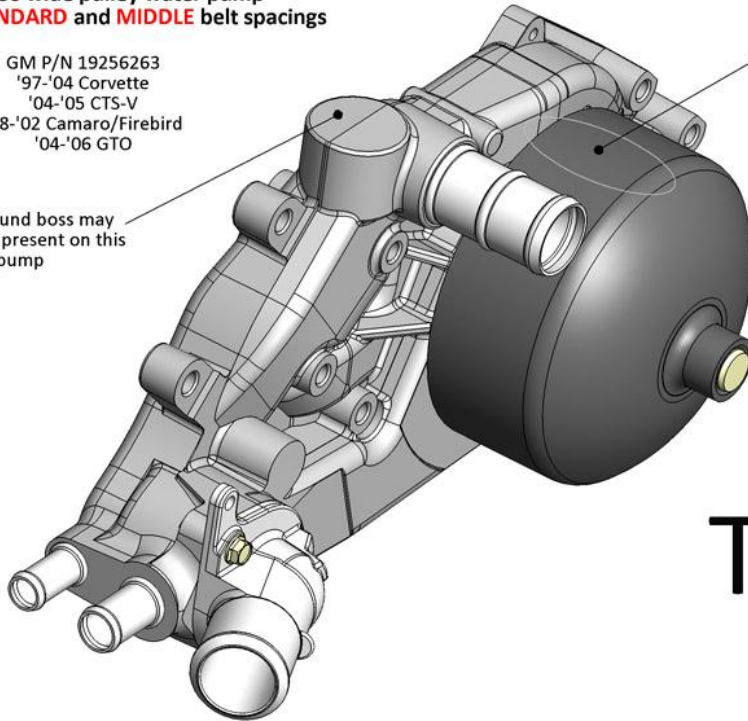

**TYPE
1**

LS2 Specific water pump
Works with **STANDARD** belt spacing

GM P/N 89018052
'05-'07 Corvette
'06-'07 CTS-V

Identifying features:
Narrow pulley and passenger's side outlet

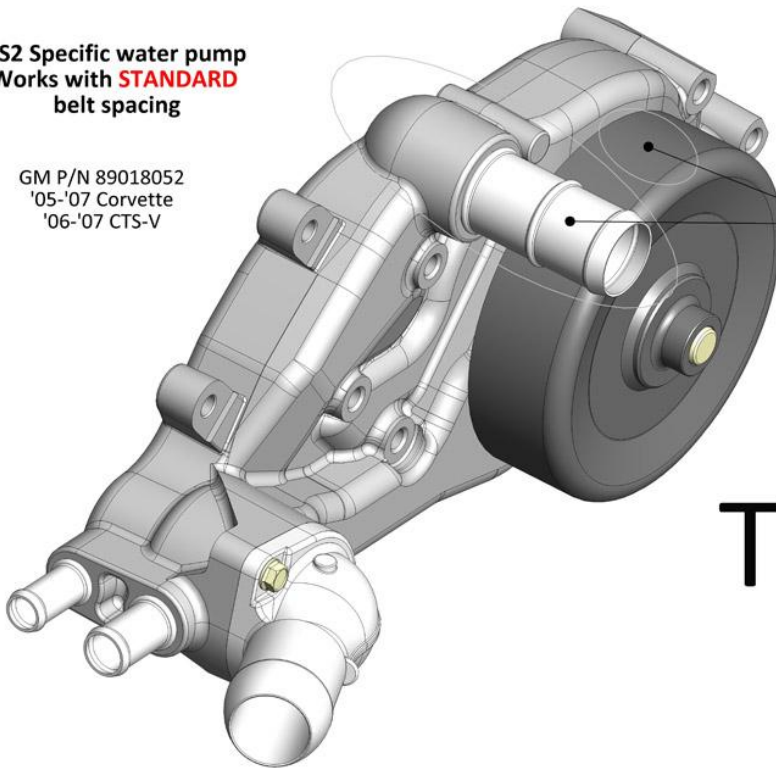

**TYPE
2**

LS3 Corvette/G8 water pump
Works with **STANDARD**
belt spacing

GM P/N 12604630
'08-UP Corvette
'08-'09 G8

Bracket Bolt Access

Either the water pump will need to be installed after the bracket or the area in red will need to be removed for bracket/spacer access. Remove the material so the boss shape is similar to that of the boss on water pump TYPE 1, 2, or 5. Otherwise, the bolt will not pass by the boss.

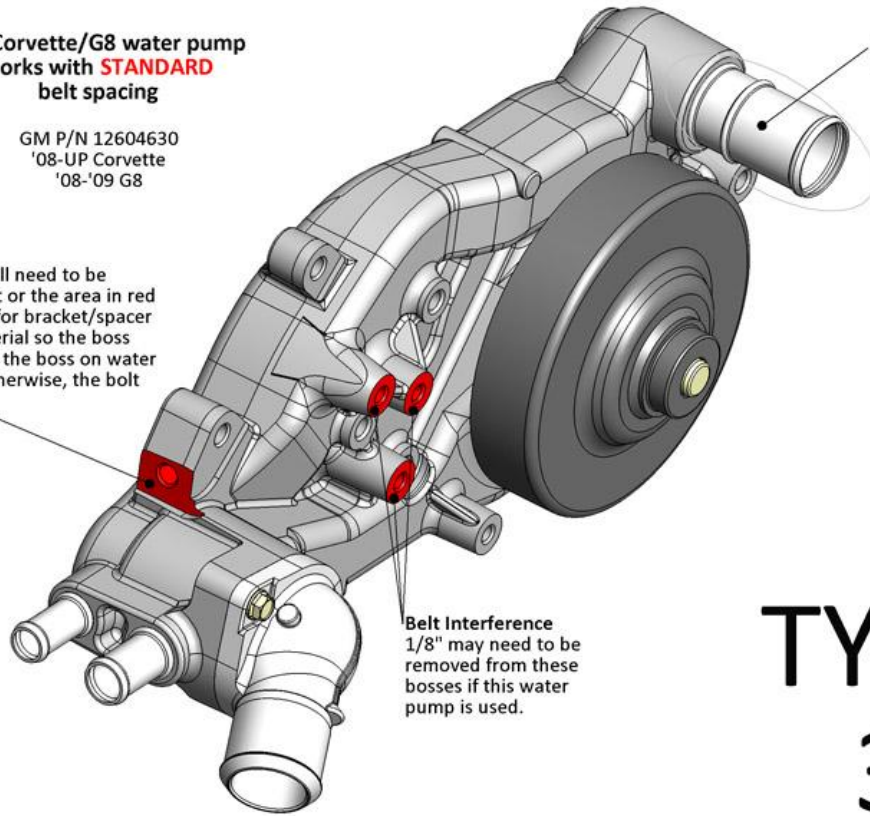

**TYPE
3**

LS3/L99 Camaro water pump
Works with **LONG** belt spacing

GM P/N 19207665
'10-UP Camaro

Identifying feature:
Long tensioner Bosses

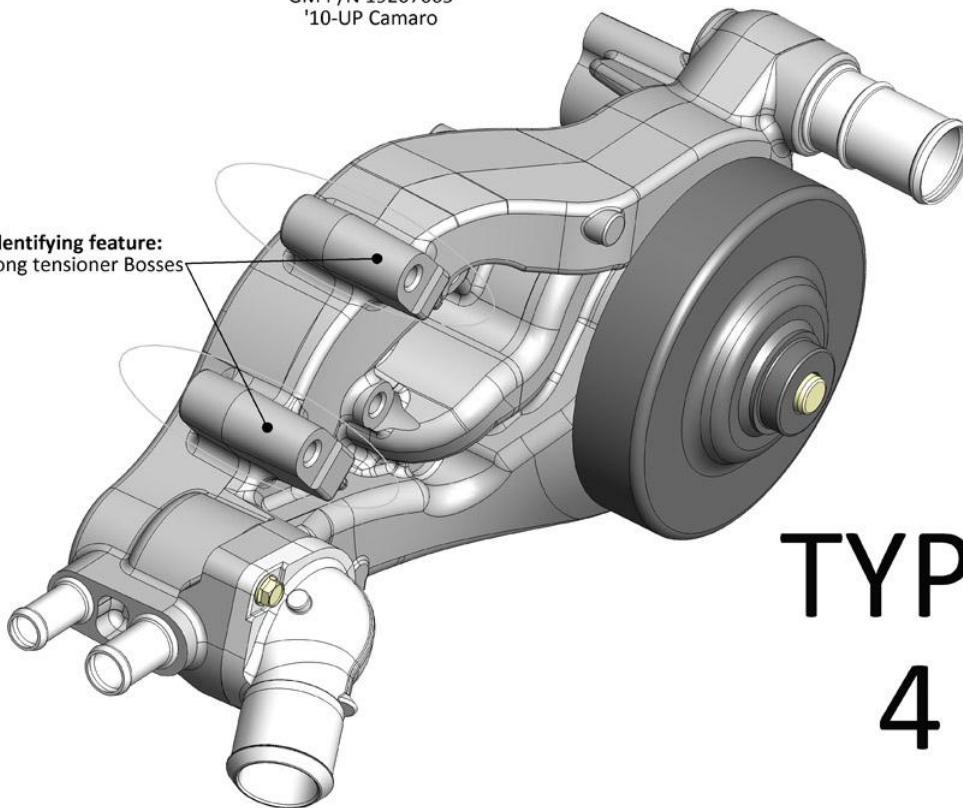

**TYPE
4**

TRUCK water pump

Works with **LONG** belt spacing

GM P/N (Numerous)
All truck LS based engines

Identifying feature:
Upward pointing
inlet

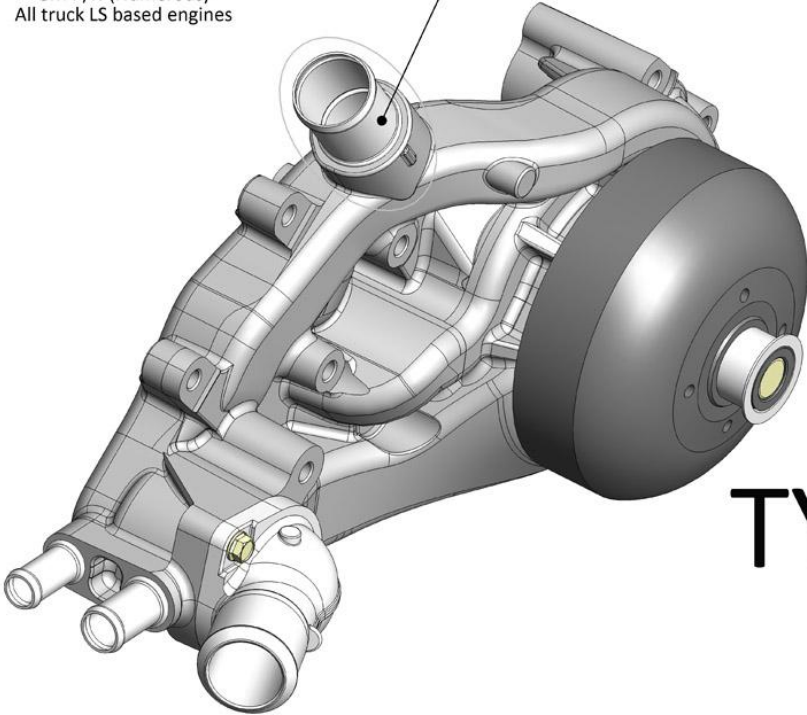









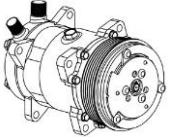

**TYPE
5**

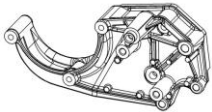
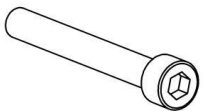
Parts List:

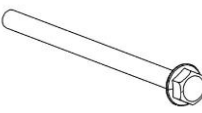
This accessory drive system requires application specific installation kit part # 21-1, 21-2, or 21-3

Parts included with 20-141 accessory drive system (see list supplied with installation kit for additional parts):

PICTURE	QTY	DESCRIPTION	APPLICATION
	1	SD508 A/C Compressor (P/N 199-101)	Passenger's Side Bracket
	1	Belt Tensioner with Bolt (P/N 97-151)	Passenger's Side Bracket
	1	Smooth Idler Pulley (P/N 97-150)	Driver's & Passenger's Side Brackets
	1	Ribbed Idler Pulley, 68mm	Passenger's Side Bracket
	1	Passenger's Side Bracket Assembly	A/C Compressor & Tensioner
	1	Socket Head Cap Bolt, M10 x 1.5 x 30	Spacer to Passenger's Side Head
	3	Flange Head Bolt, M8 x 1.25 x 35	Passenger's Side Bracket to Spacer
	2	Flange Head Bolt, M10 x 1.5 x 35	Tensioner Assembly to Passenger's Side Bracket
	1	Flange Head Bolt, M10 x 1.5 x 35	Idler Pulley to Passenger's Side Bracket
	3	Flange Head Bolt, M8 x 1.25 x 125	A/C Compressor Bolts
	3	M10 to M8 Sleeve	A/C Compressor Front Mounting Ears
	3	M8 Steel Spacer	Bracket to Rear A/C Compressor Ears
	3	M8 Flange Bushing	Rear A/C Compressor Ears
	3	Locking Nut, M8 x 1.25	Rear A/C Compressor Bolts

Assembly Instructions

Passenger's Side Bracket Installation:

If the EVAP solenoid is located on the front of the passenger's side head, it will need to be relocated when using this A/C compressor bracket.

Parts pictured may vary slightly depending on the installation kit's intended application.

This spacer is not supplied with the bracket, but is required for installation on all applications. This spacer is supplied in the installation kit 21-1, 21-2, and 21-3.

Align spacer cosmetically to the bracket before tightening the bolts.

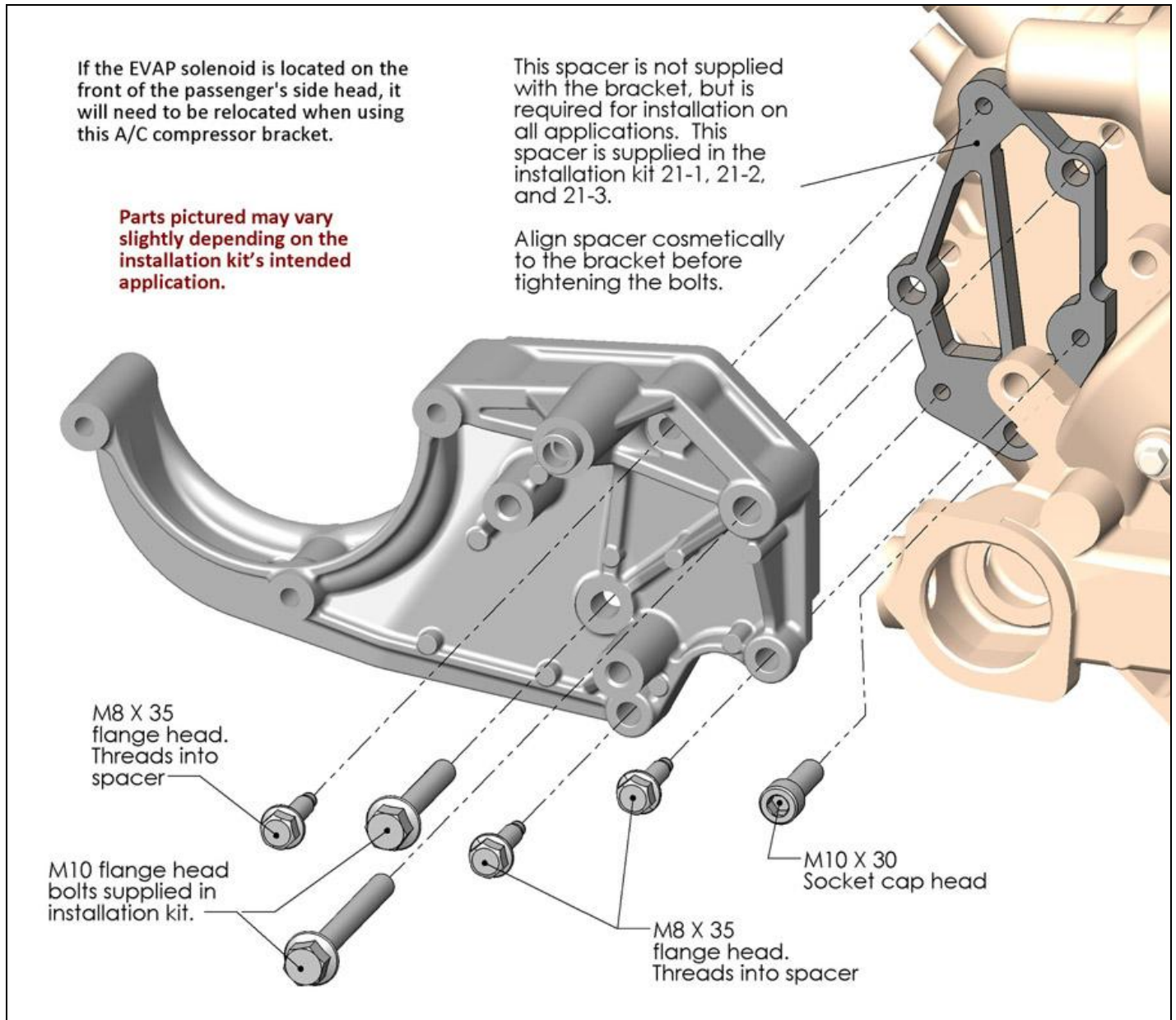

NOTE: Torque M8 bolts to 18 ft./lbs. and M10 bolts to 36 ft./lbs.

Idler & Tensioner Installation:

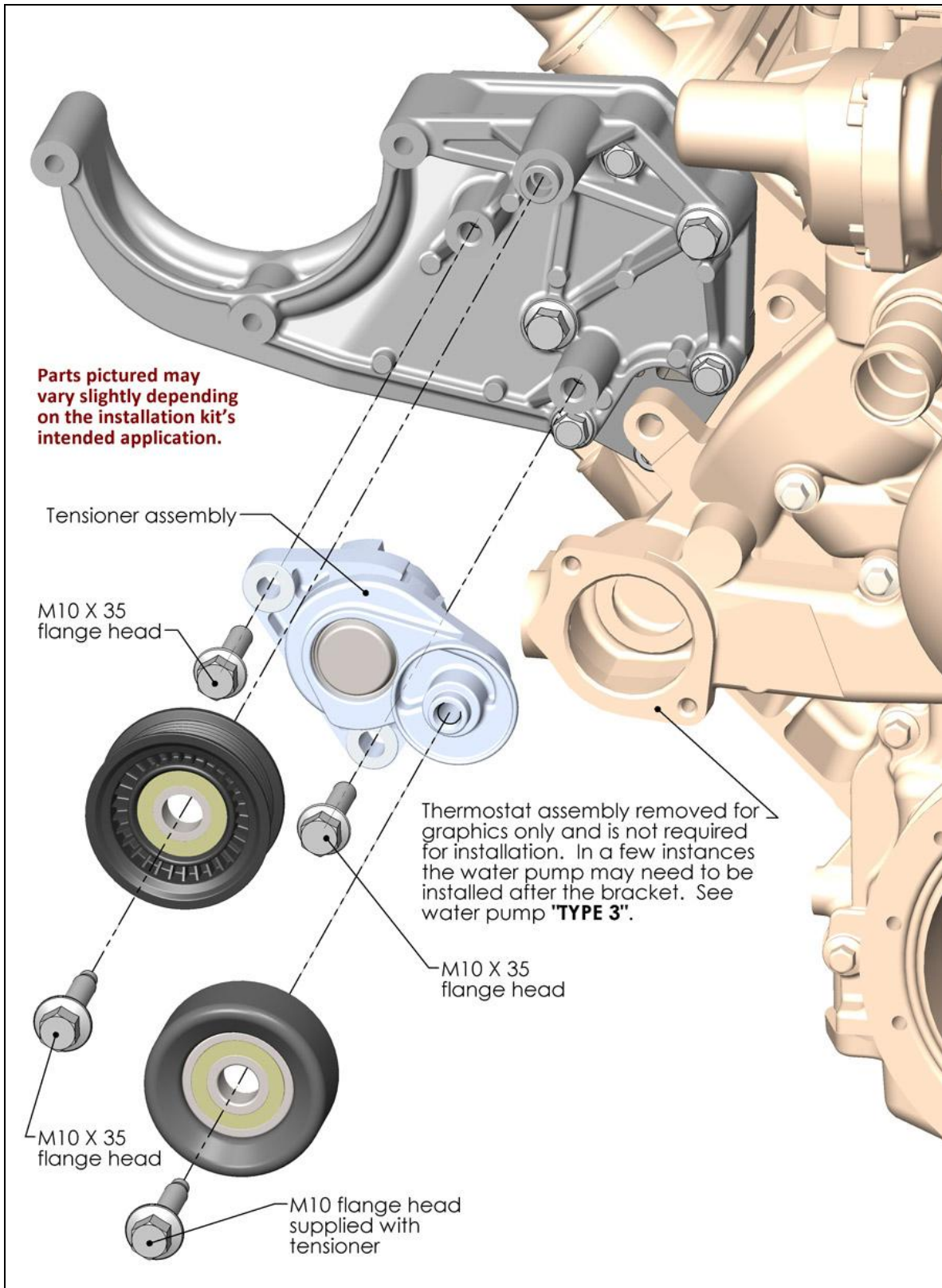

NOTE: Torque M8 bolts to 18 ft./lbs. and M10 bolts to 36 ft./lbs.

A/C Compressor Installation:

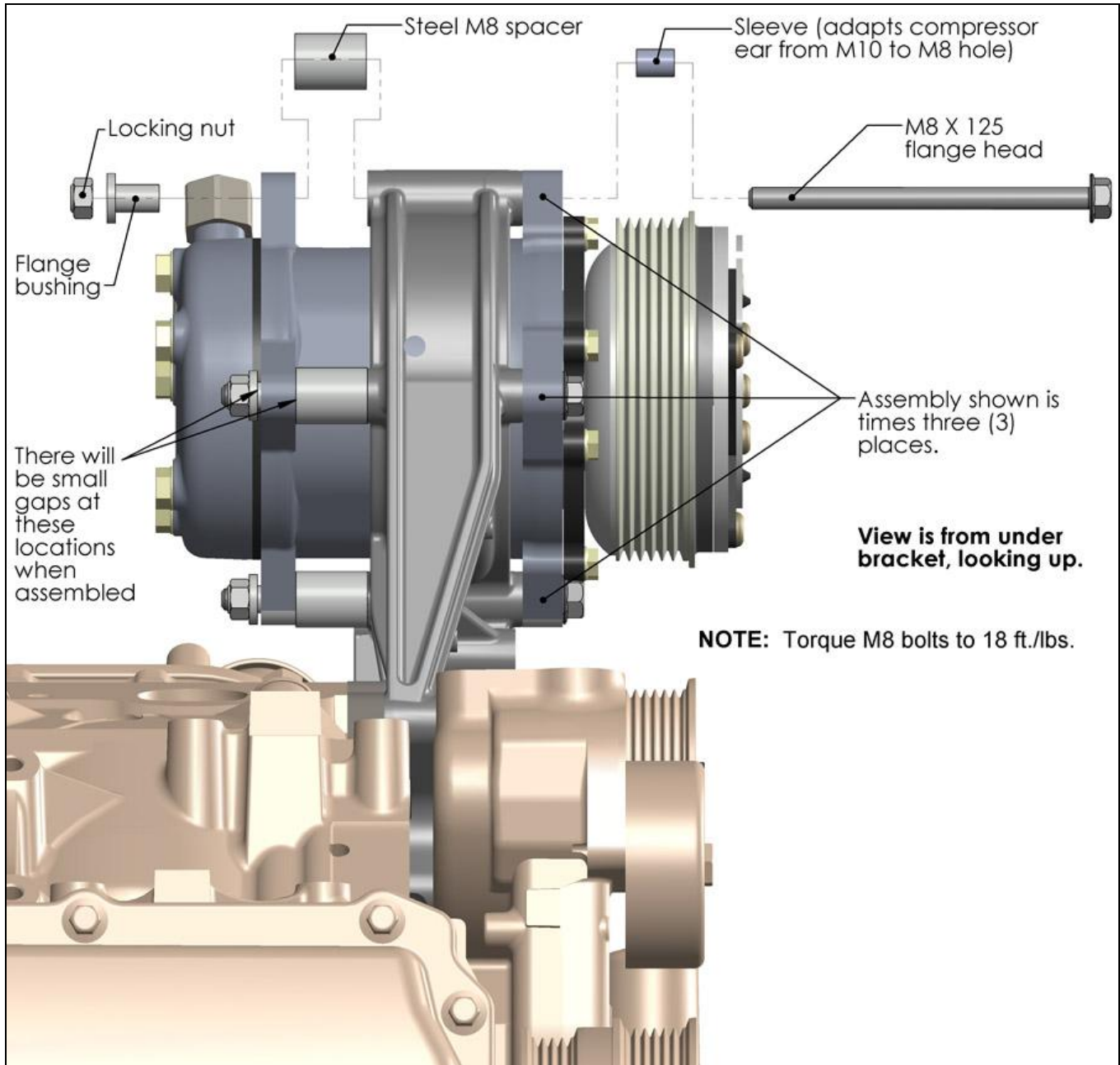

Belt Routing:

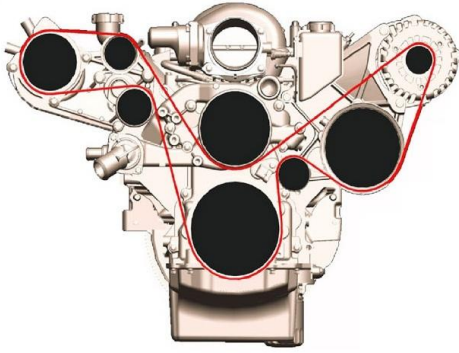

Corvette & Holley Driver's
Side Brackets (20-143)

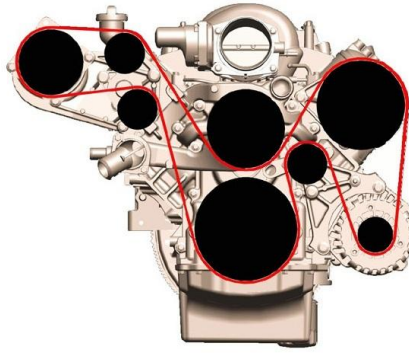

Camaro ('10-up), G8, CTS-V,
GTO, & F-Body Brackets

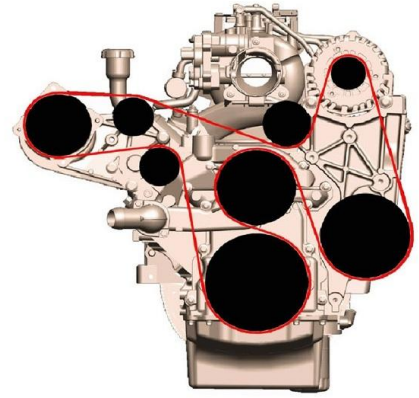

Truck Brackets

HELPFUL HINT: When installing the belt, route around all the pulleys except the water pump pulley. While fully rotating the tensioner arm, slip the belt on the smooth water pump pulley last.

Use serpentine belt part number 6PK2554 (not included) if this A/C bracket system is used with Holley alternator and P/S complete bracket system P/N 20-143.

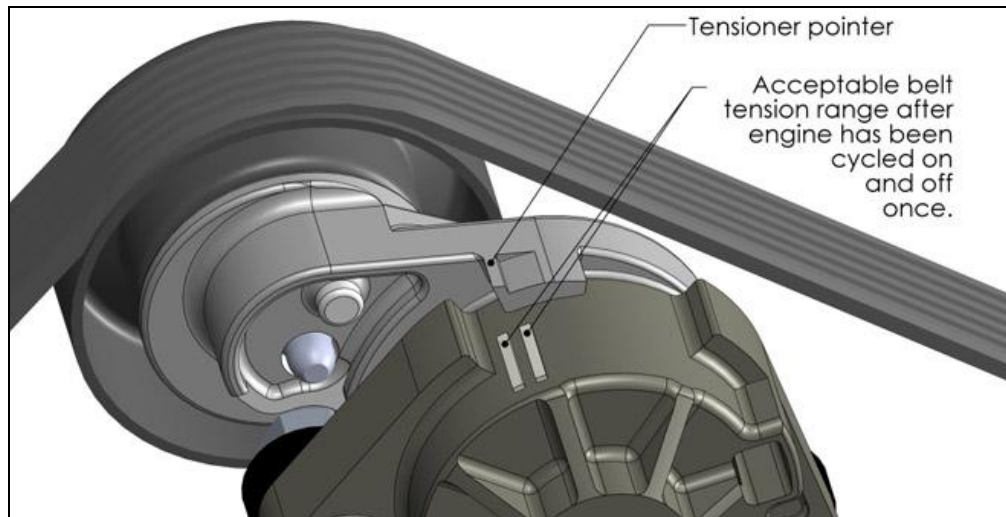

NOTE: If you are NOT using this system with P/N 20-143, you will have to measure to find the correct belt length.

To acquire this measurement, perform the following:

After all brackets and accessories are installed, route masking tape or string around the belt path. Leave the tensioner in the un-sprung position for this measurement. Mark or cut the tape/string to length and remove from the pulleys. Subtract 1 1/8" (28 mm) from the measured length to compensate for the un-sprung tensioner position. You will need to convert belt length to millimeters if measured in inches (inches X 25.4 = mm). Go to any auto parts store and ask for a 6PK0000 belt with the "0000" being the length in millimeters. For example, if you measured 2493 mm and then subtracted 28 mm, you would get 2465 mm, and the part number would be 6PK2465. Remember, if you miss on size, the driver's side idler can be moved to decrease the required belt length by 1/2".

Learn more about replacement A/C and heating parts we have.