

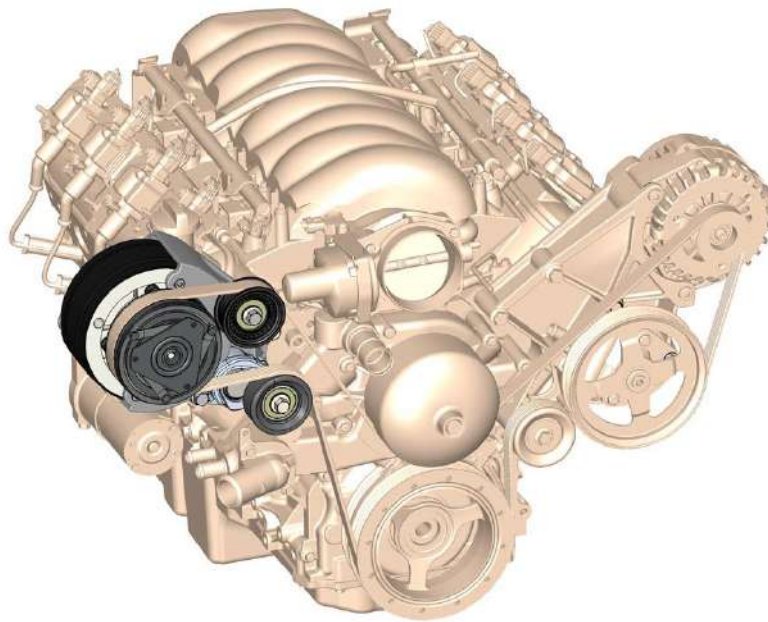

# Holley A/C Bracket System Part Number 20-140



## Table of Contents

Introduction:.....	2
Crank Pulley Belt Alignment Determination:.....	3
Overview of Parts Required (but NOT included with 20-140 accessory drive system): .....	3
Water Pump Determination:.....	4
Parts List: .....	7
Assembly Instructions .....	8
Passenger's Side Bracket Installation:.....	8
A/C Compressor Installation: .....	9
Idler & Tensioner Installation: .....	10
Belt Routing: .....	11

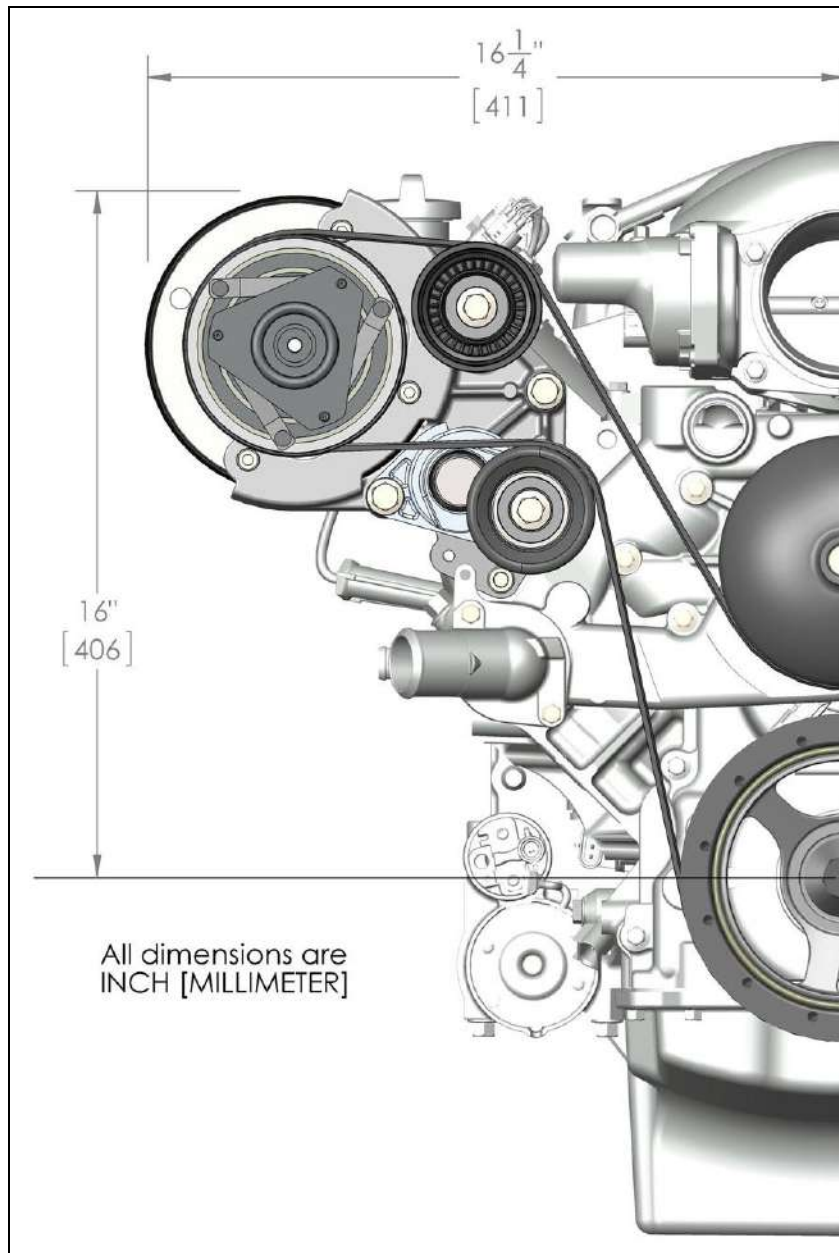

## Introduction:

Holley's accessory drive systems offer clean, economical brackets and accessories for LS engines. These accessory drives look truly at home on any LS engine as if they came from the factory this way.

Holley's complete A/C bracket systems come with virtually everything needed for installation, from the A/C compressor to the pulleys. Most LS driver's side brackets and components can be used with this kit.

The first step is to determine which belt alignment you want to proceed with. This is determined by the crank pulley and often, but not always, the water pump. If clearance to the radiator is an issue, the compact STANDARD spacing common on the Corvette may be preferred. Otherwise, it is most cost effective to retain the existing crank pulley/water pump and space the bracket and other accessories to match. **An application specific installation kit (part # 21-1, 21-2, or 21-3) is REQUIRED for this accessory drive system.**

## Crank Pulley Belt Alignment Determination:

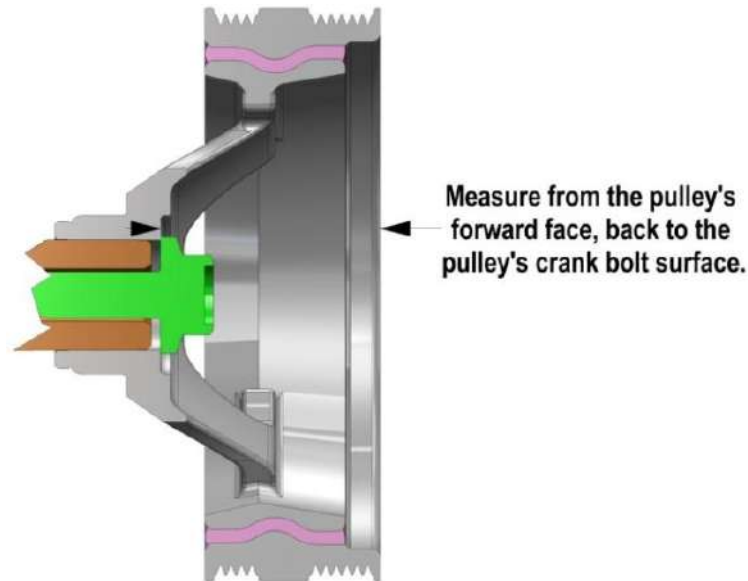

See the below chart for reference dimensions.

## Overview of Parts Required (but NOT included with 20-140 accessory drive system):

### Components with specific belt alignments

Belt Alignment Group	LS Application (Alignment Specific)	Holley Installation Kit (Alignment Specific)	Crank Pulley (Reference Dimension)		Water Pump (Alignment Specific)	Original Equipment Driver's Side Bracket
					GM #	GM # (Numerous)
Standard	Corvette / CTS-V / G8	21-1	1.5"	37 MM	19256263, 89018052, or 12604630	Most LS driver's side brackets and components can be used with this kit, but only in conjunction with the corresponding alignment's installation kit (21-1, 21-2, or 21-3)
Middle	F-body / GTO	21-2	2.25"	55 MM	19256263	
Long	Camaro ('10-UP) / Truck (all)	21-3	3"	75 MM	19207665 or any truck WP	

## Water Pump Determination:

To determine which water pump type you have, refer to the following illustrations:

**LS1/LS2/LS6 wide pulley water pump**  
Works with **STANDARD** and **MIDDLE** belt spacings

GM P/N 19256263  
'97-'04 Corvette  
'04-'05 CTS-V  
'98-'02 Camaro/Firebird  
'04-'06 GTO

This round boss may not be present on this water pump

Identifying feature:  
Wide pulley allowing for both standard and middle belt spacings

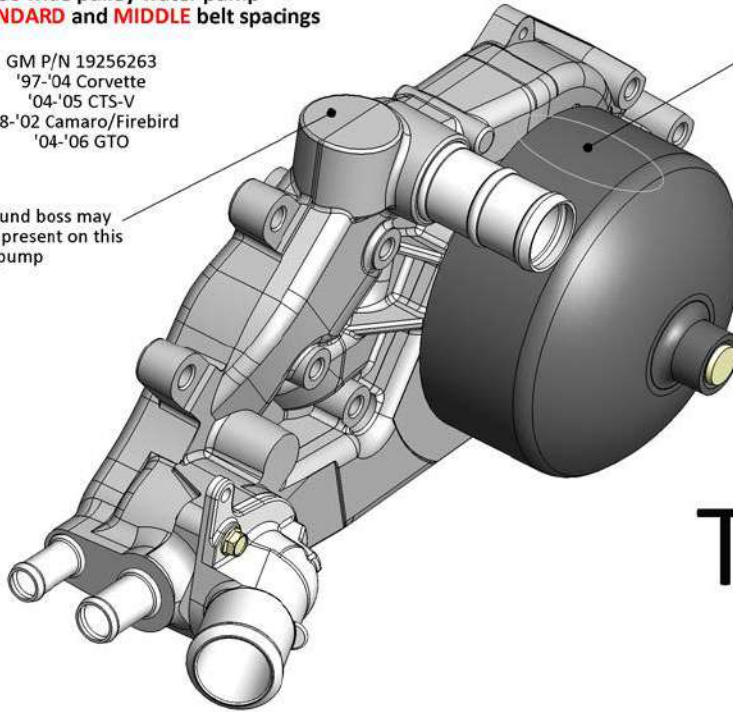

**TYPE  
1**

**LS2 Specific water pump**  
Works with **STANDARD** belt spacing

GM P/N 89018052  
'05-'07 Corvette  
'06-'07 CTS-V

Identifying features:  
Narrow pulley and passenger's side outlet

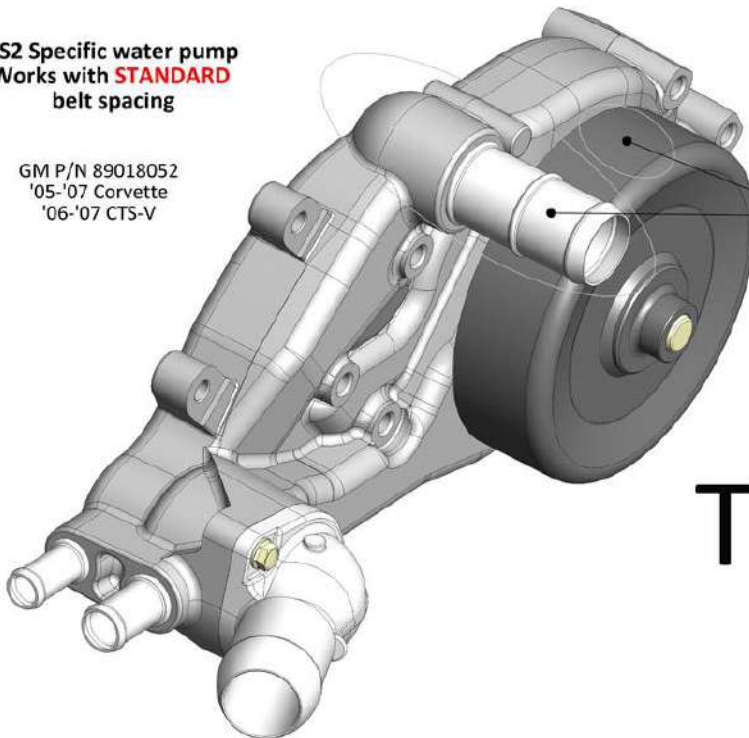

**TYPE  
2**

LS3 Corvette/G8 water pump  
Works with **STANDARD**  
belt spacing

GM P/N 12604630  
'08-UP Corvette  
'08-'09 G8

**Bracket Bolt Access**

Either the water pump will need to be installed after the bracket or the area in red will need to be removed for bracket/spacer access. Remove the material so the boss shape is similar to that of the boss on water pump TYPE 1, 2, or 5. Otherwise, the bolt will not pass by the boss.

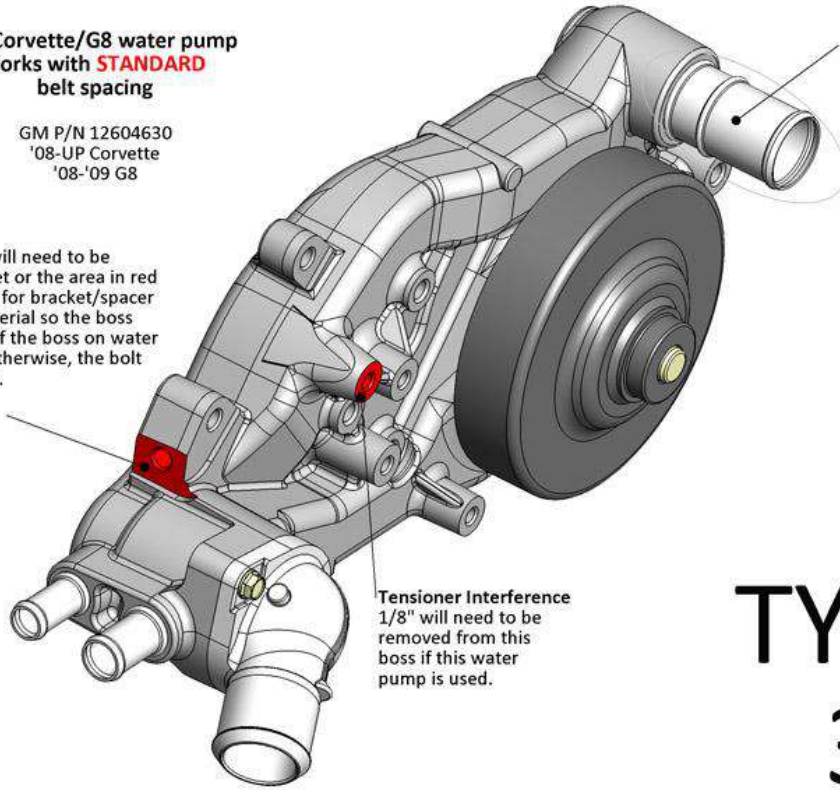

Identifying feature:  
Driver's side outlet

Tensioner Interference  
1/8" will need to be  
removed from this  
boss if this water  
pump is used.

TYPE  
3

LS3/L99 Camaro water pump  
Works with **LONG** belt spacing

GM P/N 19207665  
'10-UP Camaro

Identifying feature:  
Long tensioner Bosses

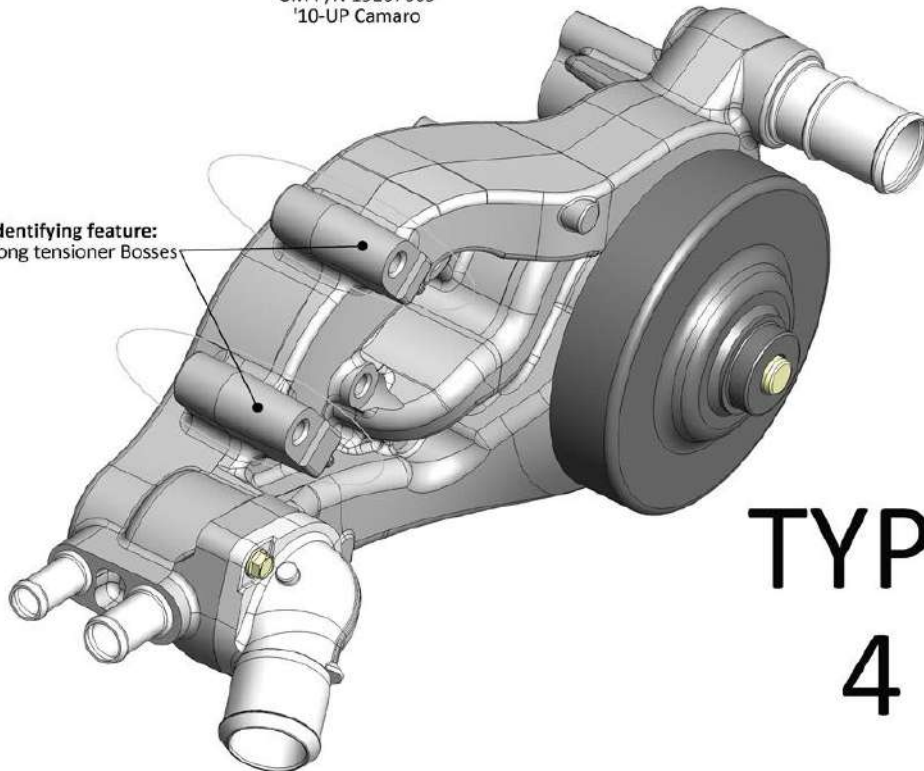

TYPE  
4

**TRUCK water pump**  
Works with **LONG** belt spacing

GM P/N (Numerous)  
All truck LS based engines

Identifying feature:  
Upward pointing  
inlet

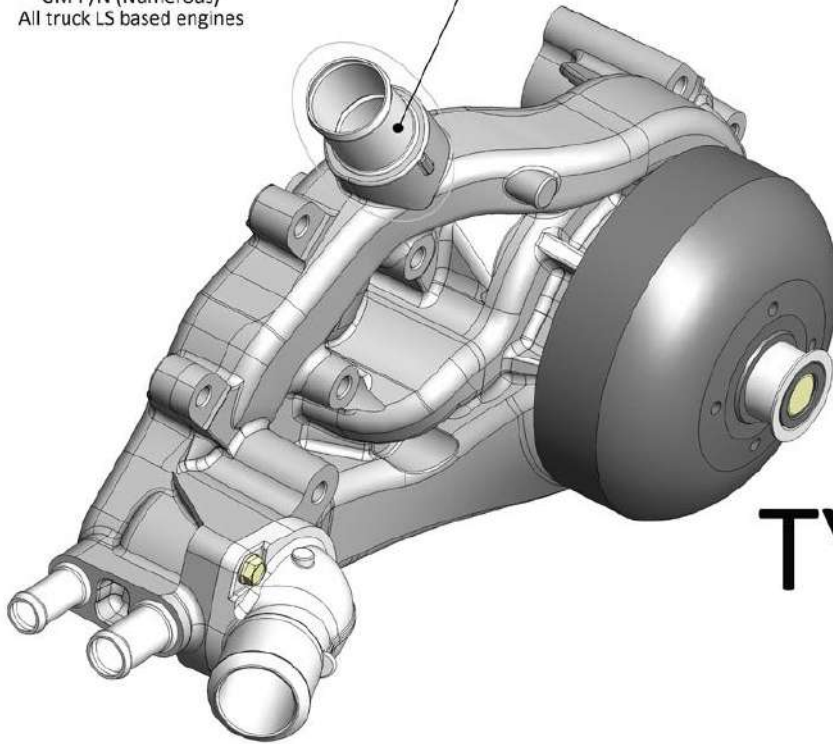







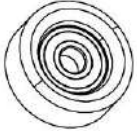

**TYPE  
5**

## Parts List:

This accessory drive system requires application specific installation kit part # 21-1, 21-2, or 21-3

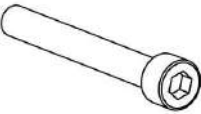
**Parts included with 20-140 accessory drive system (see list supplied with installation kit for additional parts):**

PICTURE	QTY	DESCRIPTION	APPLICATION
	1	R4 A/C Compressor (P/N 199-100)	Passenger's Side Bracket
	1	Belt Tensioner with Bolt (P/N 97-151)	Passenger's Side Bracket
	1	Smooth Idler Pulley (P/N 97-150)	Driver's & Passenger's Side Brackets
	1	Ribbed Idler Pulley, 59mm (P/N 97-153)	Passenger's Side Bracket
	1	Pigtail (P/N 199-200)	R4 A/C Compressor
	1	Passenger's Side Bracket Assembly	A/C Compressor & Tensioner
	1	Socket Head Cap Bolt, M10 x 1.5 x 30	Spacer to Passenger's Side Head
	3	Socket Head Cap Bolt, M8 x 1.25 x 100	A/C Compressor Bolts
	2	Flange Head Bolt, M8 x 1.25 x 30	Passenger's Side Bracket to Spacer
	1	Flange Head Bolt, M10 x 1.5 x 35	Tensioner Assembly to Passenger's Side Bracket
	1	Flange Head Bolt, M10 x 1.5 x 35	Idler Pulley to Passenger's Side Bracket

# Assembly Instructions

## **Passenger's Side Bracket Installation:**

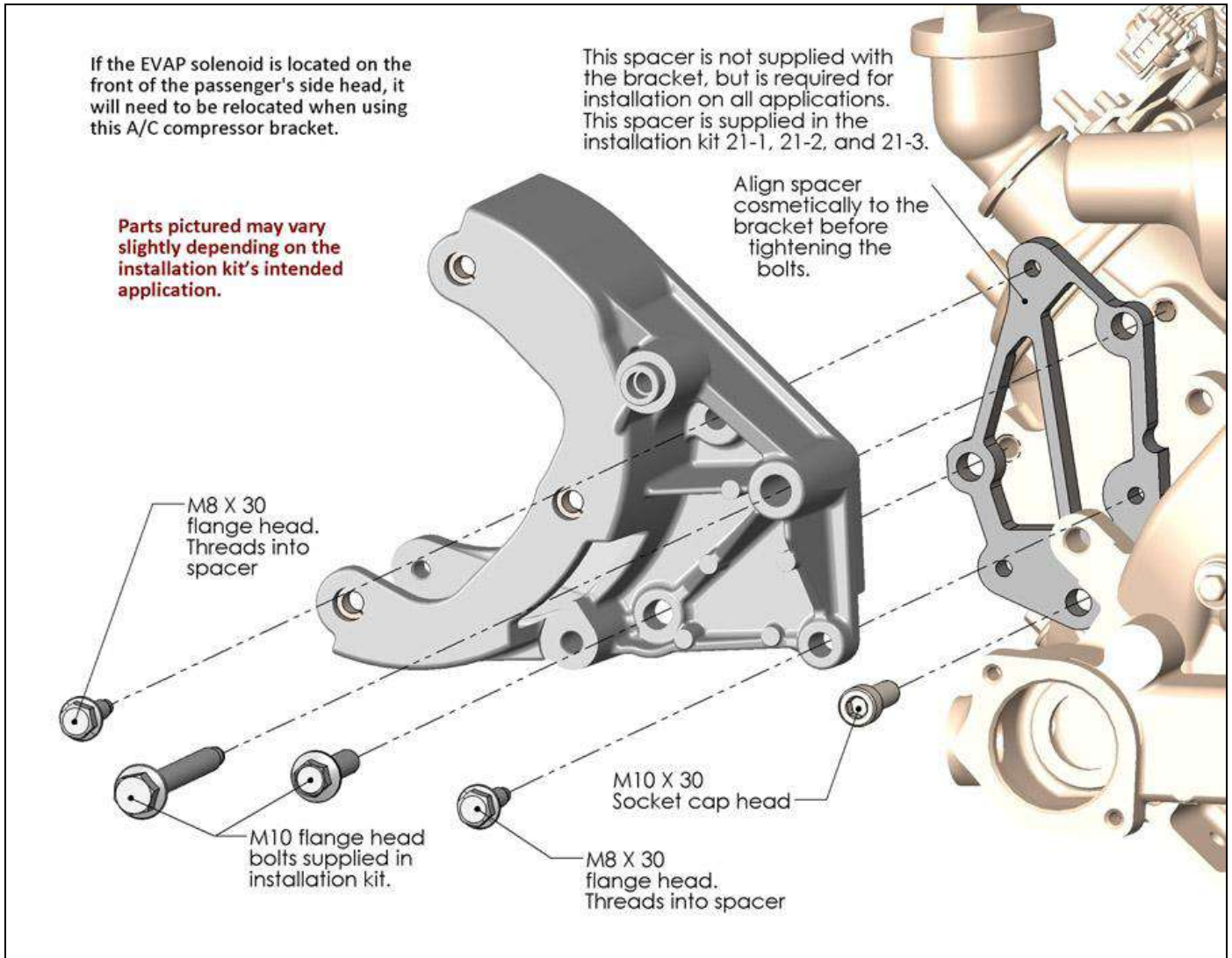

**NOTE:** Torque M8 bolts to 18 ft./lbs. and M10 bolts to 36 ft./lbs.



## A/C Compressor Installation:

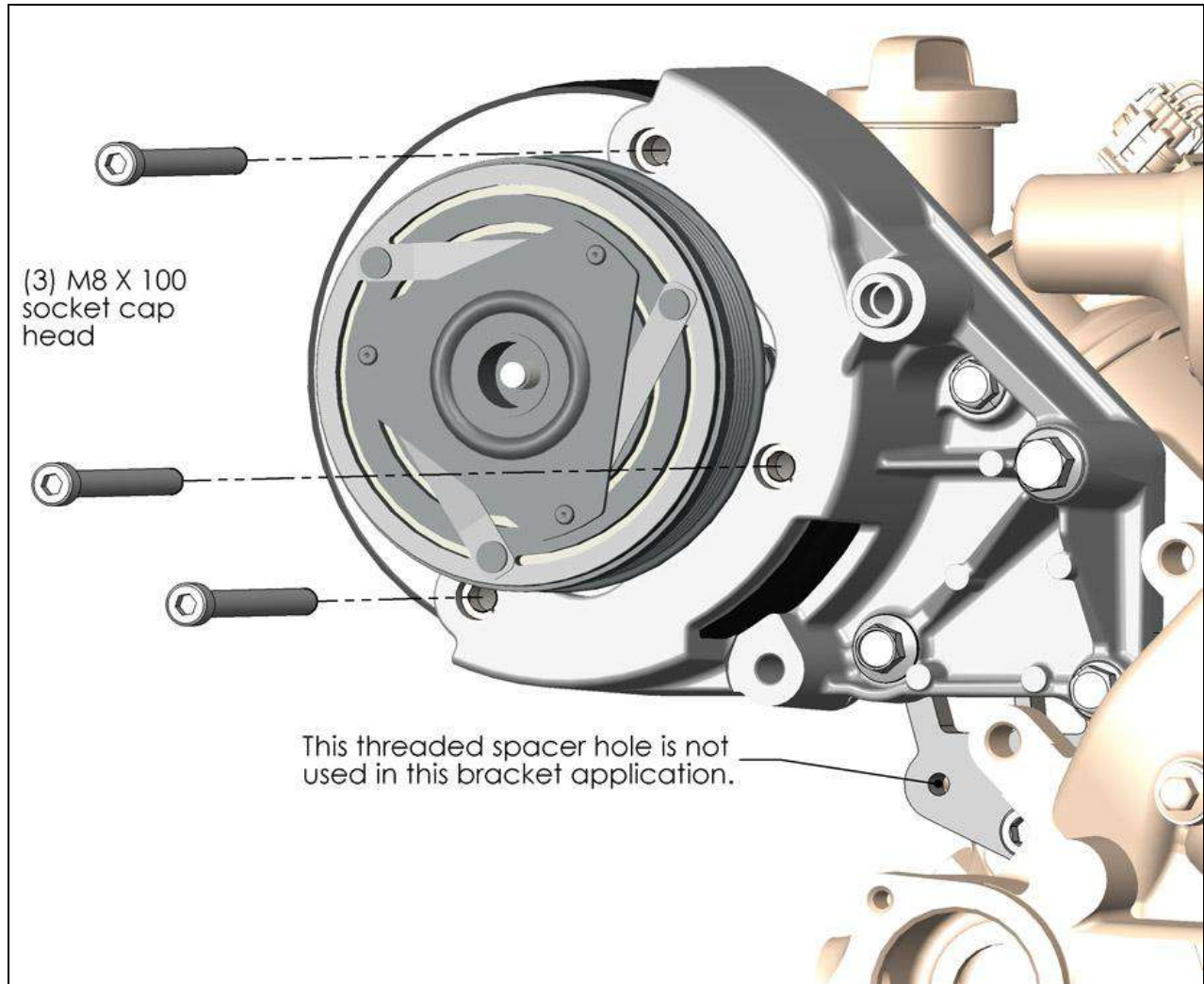

**NOTE:** Torque M8 bolts to 18 ft./lbs. and M10 bolts to 36 ft./lbs.

**HELPFUL HINT:** There is typically no polarity when wiring the two connectors for the A/C clutch. In a few cases a diode may be inline. After installation, if the clutch does not function properly, reverse the polarity.

## Idler & Tensioner Installation:

Parts pictured may vary slightly depending on the installation kit's intended application.

Some spacers may not be included or required, depending on which installation kit is being installed. No tensioner spacers will be used if installing "TYPE 2, 3, OR 4" water pumps.

This spacer is included in installation kit P/N 21-1 and is to be used with "TYPE 1" water pumps only.

Tensioner assembly

M10 X 35  
flange head

This spacer is included in installation kits P/N 21-2 and 21-3 and is to be used with "TYPE 1 & 5" water pumps only.

M10 flange head  
bolts included with  
installation kit.

M10 flange head  
supplied with  
tensioner

Thermostat assembly removed for graphics only and is not required for installation. In a few instances the water pump may need to be installed after the bracket. See water pump "TYPE 3"

**NOTE:** Torque M8 bolts to 18 ft./lbs. and M10 bolts to 36 ft./lbs.

## Belt Routing:

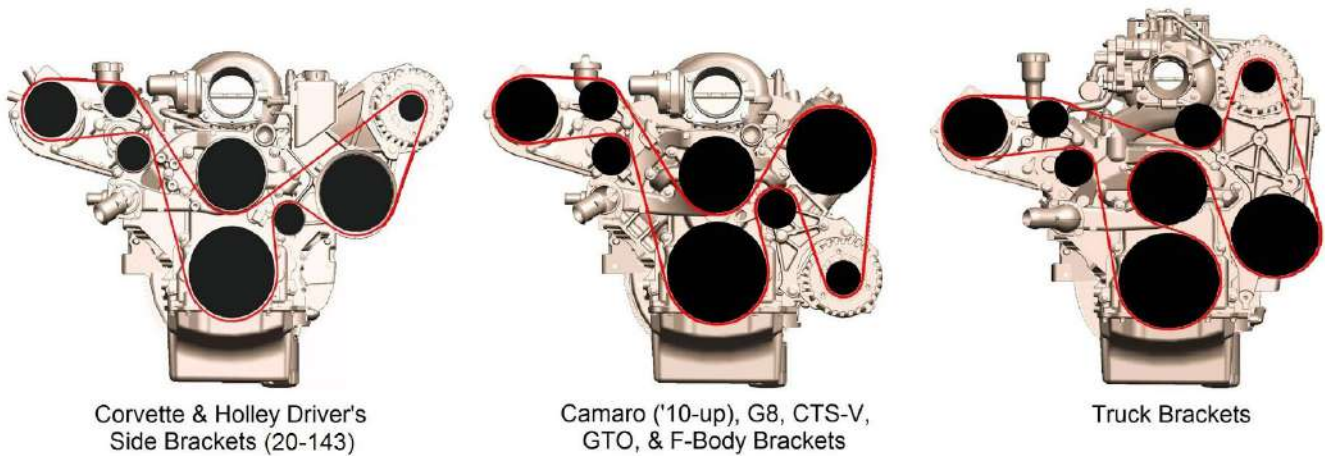

**HELPFUL HINT:** When installing the belt, route around all the pulleys except the water pump pulley. While fully rotating the tensioner arm, slip the belt on the smooth water pump pulley last.

Use serpentine belt part number 6PK2490 (not included) if this A/C bracket system is used with Holley alternator and P/S complete bracket system P/N 20-143.

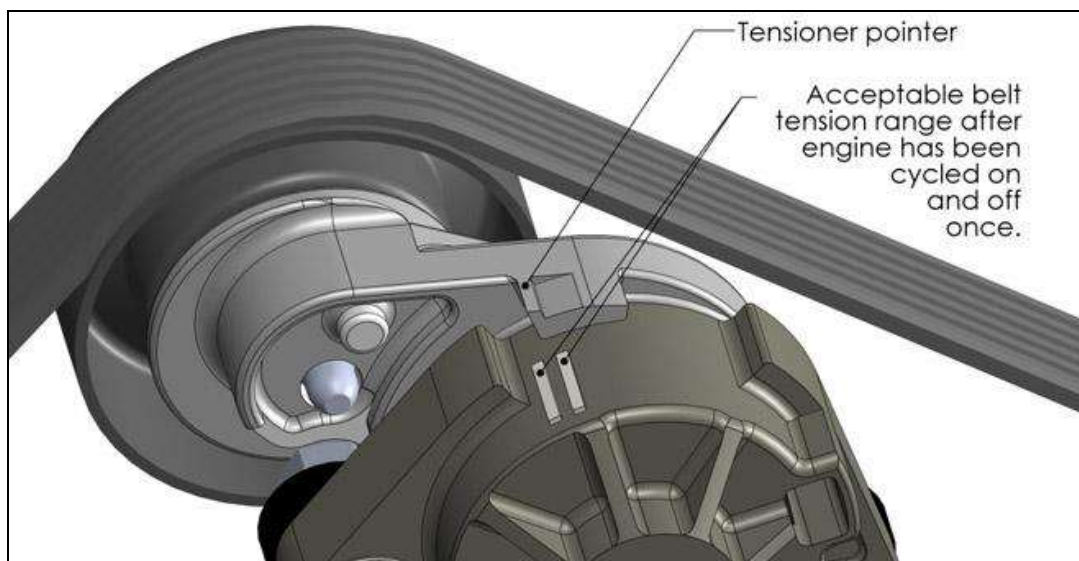

**NOTE:** If you are NOT using this system with P/N 20-143, you will have to measure to find the correct belt length.

To acquire this measurement, perform the following:



After all brackets and accessories are installed, route masking tape or string around the belt path. Leave the tensioner in the un-sprung position for this measurement. Mark or cut the tape/string to length and remove from the pulleys. Subtract 1 1/8" (28 mm) from the measured length to compensate for the un-sprung tensioner position. You will need to convert belt length to millimeters if measured in inches (inches X 25.4 = mm). Go to any auto parts store and ask for a 6PK0000 belt with the "0000" being the length in millimeters. For example, if you measured 2493 mm and then subtracted 28 mm, you would get 2465 mm, and the part number would be 6PK2465. Remember, if you miss on size, the driver's side idler can be moved to decrease the required belt length by 1/2".



## Installation Kit for LS Accessory Drive Bracket Kits Part Number 21-1

Required for applications with **standard belt alignment\***

### Parts list

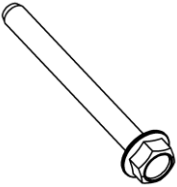
PICTURE	QTY	DESCRIPTION	APPLICATION
	1	Passenger's Side Bracket Spacer	Between Bracket & Head
	1	Tensioner Spacer, 3.12mm thick	Between Tensioner & Passenger's Side Bracket (Use with Type 1 water pump & R4 A/C compressor bracket only)
	1	Flange Head Bolt, M10 x 1.5 x 35	Tensioner to Water Pump (Use with R4 A/C compressor bracket only)
	1	Flange Head Bolt, M10 x 1.5 x 45	Passenger's Side Bracket to Head
	1	Flange Head Bolt, M10 x 1.5 x 60	Driver's Side Bracket to Head
	3	Flange Head Bolt, M10 x 1.5 x 70	Driver's Side Bracket to Head
	1	Flange Head Bolt, M10 x 1.5 x 70	Passenger's Side Bracket to Head (Use with Sanden A/C compressor bracket only)
	1	Flange Head Bolt, M10 x 1.5 x 90	Passenger's Side Bracket to Head (Use with R4 A/C compressor bracket only)



\* Some bolts and spacers may not be used for your application.



# Installation Kit for LS Accessory Drive Bracket Kits Part Number 21-2

Required for applications with **middle belt alignment\***

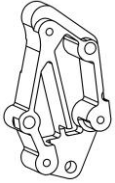
## Parts list

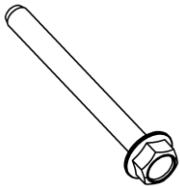
PICTURE	QTY	DESCRIPTION	APPLICATION
	1	Driver's Side Bracket Spacer	Between Bracket & Head
	1	Passenger's Side Bracket Spacer	Between Bracket & Head
	1	Tensioner Spacer	Between tensioner & water pump (Use with R4 A/C compressor bracket only)
	1	Flange Head Bolt, M10 x 1.5 x 60	Tensioner to Water Pump (Use with R4 A/C compressor bracket only)
	1	Flange Head Bolt, M10 x 1.5 x 65	Passenger's Side Bracket to Head
	1	Flange Head Bolt, M10 x 1.5 x 85	Driver's Side Bracket to Head
	3	Flange Head Bolt, M10 x 1.5 x 95	Driver's Side Bracket to Head
	1	Flange Head Bolt, M10 x 1.5 x 95	Passenger's Side Bracket to Head (Use with Sanden A/C compressor bracket only)
	1	Flange Head Bolt, M10 x 1.5 x 110	Passenger's Side Bracket to Head (Use with R4 A/C compressor bracket only)

\*Some bolts and spacers may not be used for your application.



# Installation Kit for LS Accessory Drive Bracket Kits Part Number 21-3

Required for applications with **long belt alignment\***

**Parts list**

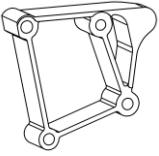
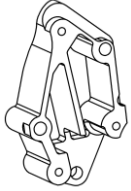
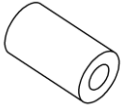
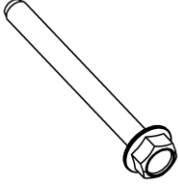
PICTURE	QTY	DESCRIPTION	APPLICATION
	1	Driver's Side Bracket Spacer	Between Bracket & Head
	1	Passenger's Side Bracket Spacer	Between Bracket & Head
	1	Tensioner Spacer	Between Tensioner to Water Pump (Use with Type 5 water pump & R4 A/C compressor bracket only)
	1	Flange Head Bolt, M10 x 1.5 x 75	Tensioner to Water Pump (Use with R4 A/C compressor bracket only)
	1	Flange Head Bolt, M10 x 1.5 x 85	Passenger's Side Bracket to Head
	1	Flange Head Bolt, M10 x 1.5 x 100	Driver's Side Bracket to Head
	3	Flange Head Bolt, M10 x 1.5 x 115	Driver's Side Bracket to Head
	1	Flange Head Bolt, M10 x 1.5 x 115	Passenger's Side Bracket to Head (Use with Sanden A/C compressor bracket only)
	1	Flange Head Bolt, M10 x 1.5 x 130	Passenger's Side Bracket to Head (Use with R4 A/C compressor bracket only)

\* Some bolts and spacers may not be used for your application.

Check out the collection of performance engine parts we offer.